

Publication No. 518
April 2007
Part No. 41571.18
Revision: 11.10.07

FW6000

ROTARY FLEX WING MOWER



Parts Manual

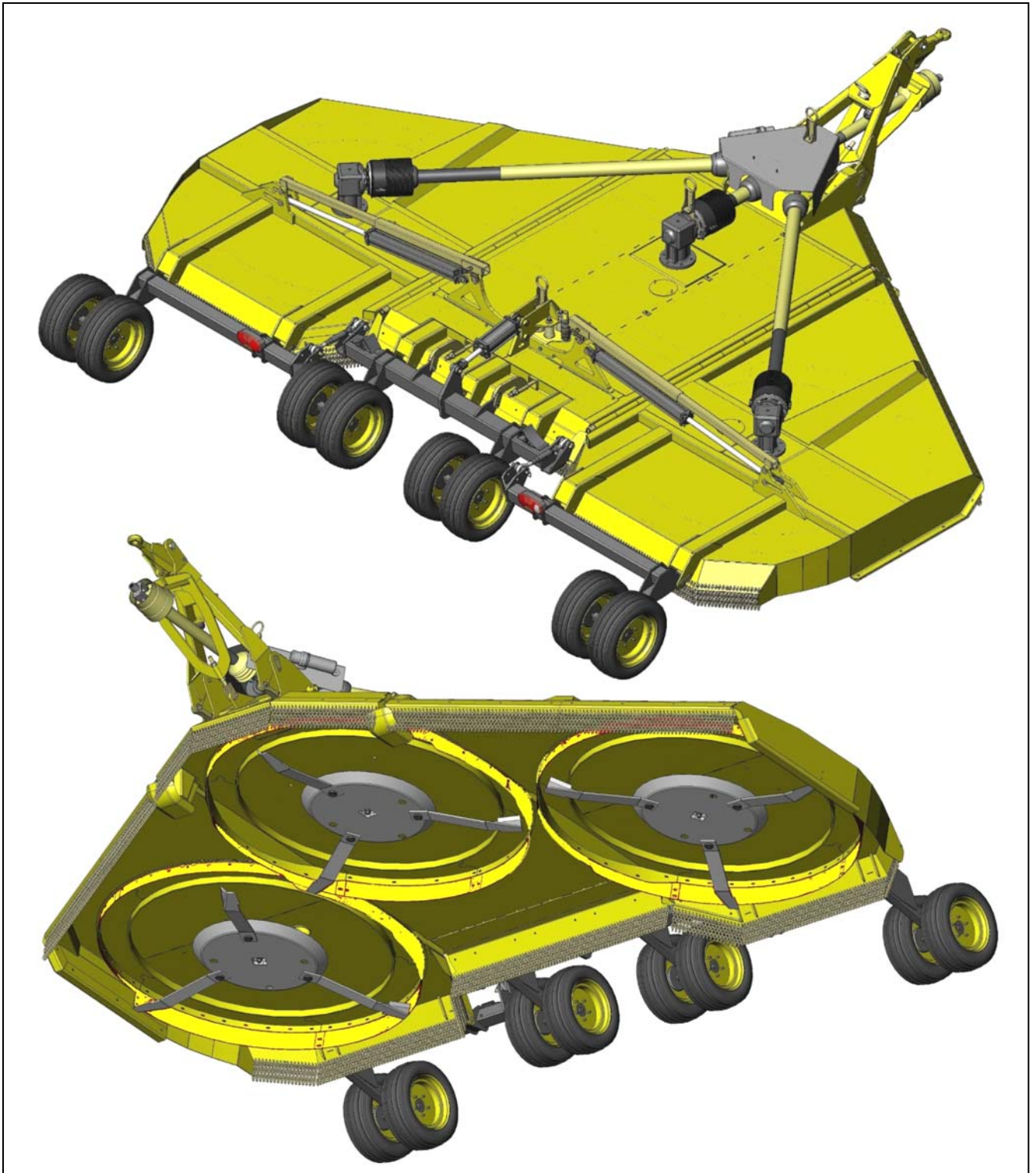



For best performance ...

USE ONLY GENUINE McCONEL SERVICE PARTS

To be assured of the latest design improvements purchase your 'Genuine Replacements' from the 'Original Equipment Manufacturer'

McCONEL LIMITED

Through your local Dealer or Stockist

Always quote:

- ***Machine Type***
- ***Serial Number***
- ***Part Number***

Design improvements may alter some of the parts listed in this manual – the latest part will always be supplied when it is interchangeable with an earlier one.

**Temeside Works
Ludlow
Shropshire SY8 1JL
United Kingdom**

**Telephone: ++44 (0)1584 873131
www.mcconel.com**

LIST OF CONTENTS

	Page No.
Low Hitch Assembly	1
High Hitch Assembly	3
Centre Deck & Wings Assembly	5
Skid Assembly – <i>Side Mounted Version</i>	7
Skid Assembly – <i>Bottom Mounted Version</i>	8
Baffles Assembly	9
Chain Guards Assembly	11
Axles & Wheels Assembly	13
Levelling System Assembly	15
Blade Pans & Blades Assembly	17
Shredder Blades Assembly	19
Gearboxes & Driveshafts Assembly	21
Divider Gearbox Assembly	23
Centre Gearbox Assembly	25
L/H Wing Gearbox Assembly	27
R/H Wing Gearbox Assembly	29
Centre Gearbox Driveshaft Assembly	31
Wing Gearbox Driveshaft Assembly	32
Slip Clutch Assembly	33
Driveshaft Guards Assembly	35
Axle Ram Assembly	37
Wing Ram Assembly	39
Hydraulic Hose Installation – <i>Deck Mounted Version</i>	41
Hydraulic Hose Installation – <i>Suspended Version</i>	43
Rear Lighting Kit Assembly	45
Machine Decals	47

Model: FW6000



LOW HITCH ASSEMBLY

Module:
1058759

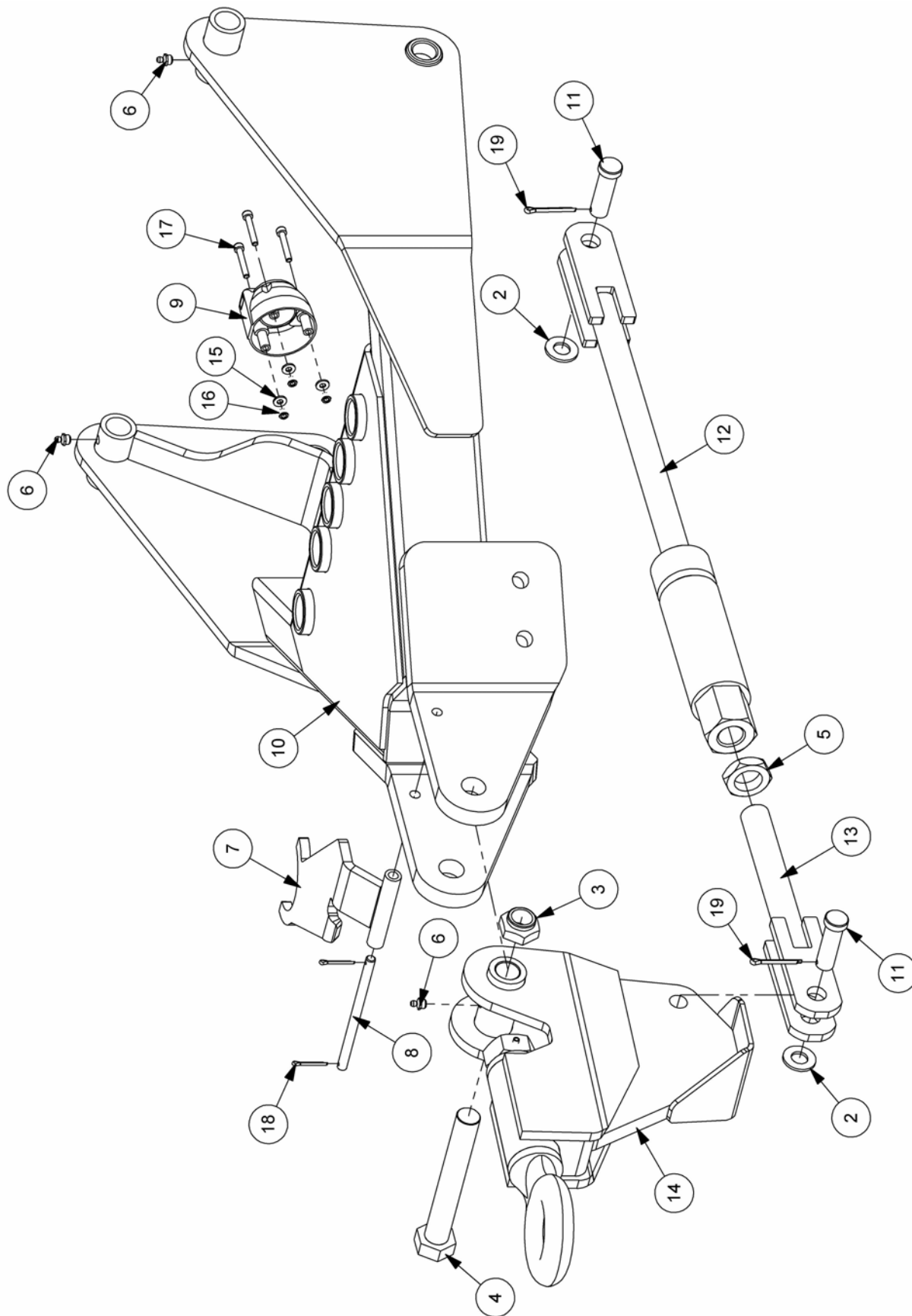

Model: FW6000



LOW HITCH ASSEMBLY

REF.	QTY.	PART No.	DESCRIPTION
		1058759	LOW HITCH ASSEMBLY
1	1	00764515	SAFETY CHAIN <i>(not illustrated)</i>
2	2	0100106	FLAT WASHER
3	1	0141009	CLEVELOC NUT
4	1	0211569	BOLT
5	1	05.948.04	NUT
6	3	0901121	GREASE NIPPLE
7	1	21182.30	PTO SUPPORT
8	1	21182.36	PIVOT BAR
9	1	21678.07	7 PIN SOCKET - 12V
10	1	22178.01	HITCH (LOW)
11	2	45213.02	PIN - PINTLE ROD REAR
12	1	45232.11	LONG CONTROL ROD
13	1	45232.12	CONTROL ROD
14	1	45235.07	PINTLE EYE HITCH BRACKET
15	3	9100103	FLAT WASHER
16	3	9163003	NYLOC NUT
17	3	9343083	CAPSCREW
18	2	9501255	SPLIT PIN
19	2	9501406	SPLIT PIN

Model: FW6000



HIGH HITCH ASSEMBLY

Module:
1058757

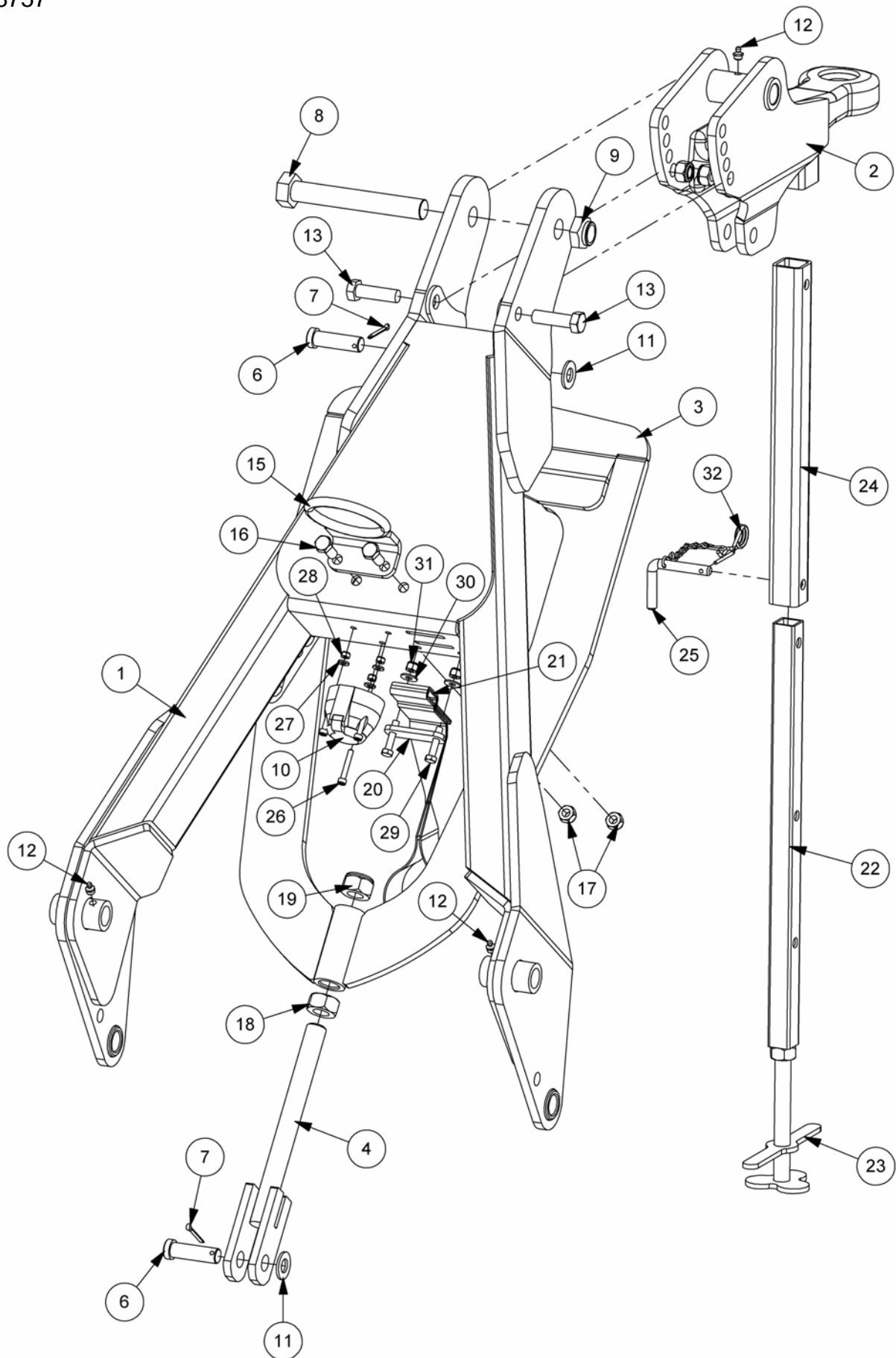

HIGH HITCH ASSEMBLY

REF.	QTY.	PART No.	DESCRIPTION
		1058757	HIGH HITCH ASSEMBLY
1	1	45830.04	HIGH HITCH
2	1	45235.06	FIXED EYE HITCH BRACKET
3	1	22241.01	LINK
4	1	22242.01	ADJUSTMENT LINK
5	1	00764515	SAFETY CHAIN
6	2	45213.02	PIN - PINTLE ROD REAR
7	2	9501406	SPLIT PIN
8	1	0211569	BOLT
9	1	0141009	CLEVELOC NUT
10	1	21678.07	7 PIN SOCKET
11	2	0100106	FLAT WASHER
12	3	0901121	GREASE NIPPLE
13	2	9313117	SETSCREW
14	2	9163007	NYLOC NUT
15	1	21844.01	HOSE LOOP
16	2	9313066	SETSCREW
17	2	9163006	NYLOC NUT
18	1	9113009	NUT
19	1	9163009	NYLOC NUT
20	1	22261.01	CLAMP - PTO STRAP
21	1	45830.46	STRAP
22	1	22254.01	PARKING PROP INNER
23	1	22255.01	ADJUSTABLE LEG
24	1	22256.01	PARKING PROP OUTER
25	1	22260.01	LOCKING PIN
26	3	9343083	CAPSCREW
27	3	9100103	FLAT WASHER
28	3	9163003	NYLOC NUT
29	2	9313084	SETSCREW
30	2	9100104	FLAT WASHER
31	2	9163004	NYLOC NUT
32	1	22262.01	GRIP CLIP & CHAIN

Model: FW6000



CENTRE DECK & WINGS

Module:
1058750

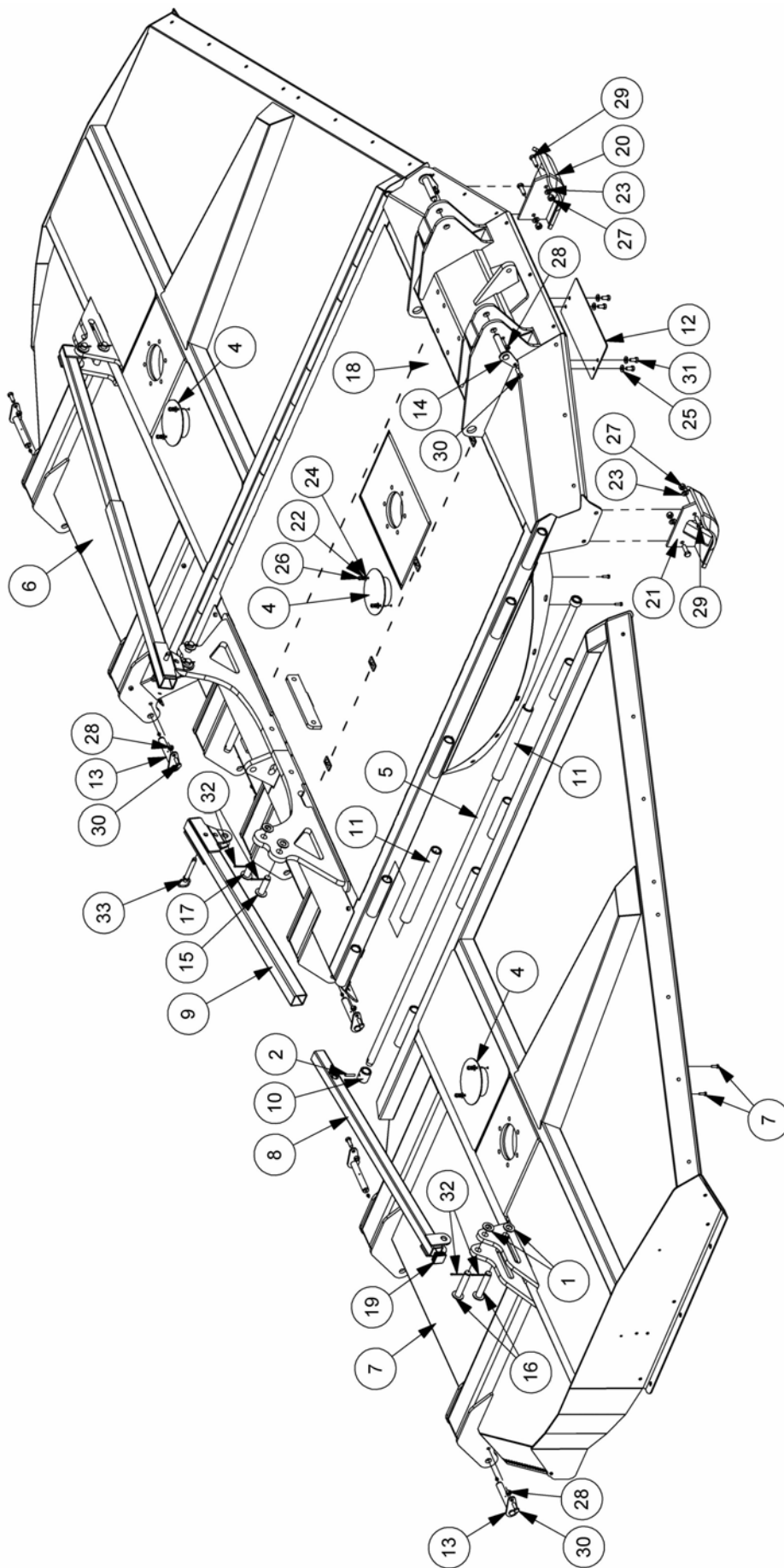

CENTRE DECK & WINGS

REF.	QTY.	PART No.	DESCRIPTION
		1058750	CENTRE DECK & WINGS ASSEMBLY
1	8	0100109	FLAT WASHER
2	2	0422528	SPRING DOWEL
3	7	0901121	GREASE NIPPLE
4	3	21833.01	COVER
5	2	22081.01	HINGE PIN
6	1	22108.02	L/H WING
7	1	22109.02	R/H WING
8	2	22155.02	INNER TRANSPORT SUPPORT ARM
9	2	22156.02	OUTER TRANSPORT SUPPORT ARM
10	2	22158.01	HINGE PIN LOCKING BOSS
11	4	22159.01	HINGE SPACER TUBE
12	1	22170.01	ACCESS HATCH (DIVIDER GEARBOX BOLT)
13	7	22173.01	AXLE PIVOT PIN
14	2	22173.03	HITCH PIVOT PIN
15	2	22174.01	PIN (WING RAM BASE END)
16	4	22175.01	PIN (WING RAM ROD END)
17	2	22237.01	PIVOT PIN
18	1	22225.01	CENTRE DECK
19	2	41580.04	PLASTIC PLUG
20	1	45239.01	SKID SHOE - L/H
21	1	45239.02	SKID SHOE - R/H
22	6	9100204	SPRING WASHER
23	4	05.281.14	FLAT WASHER
24	6	9100104	FLAT WASHER
25	4	9100106	FLAT WASHER
26	6	9113004	NUT
27	4	9100022	SELF LOCKING NUT
28	9	T8095	SELF-LOCKING NUT
29	4	9200017	BOLT
30	9	9300139	SETSCREW
31	4	9313056	SETSCREW
32	8	9501406	SPLIT PIN
33	2	6310220	PIN C/W LINCH PIN ON CHAIN

Model: FW6000



SKID ASSEMBLY (Side Mount)

Module:
1058753

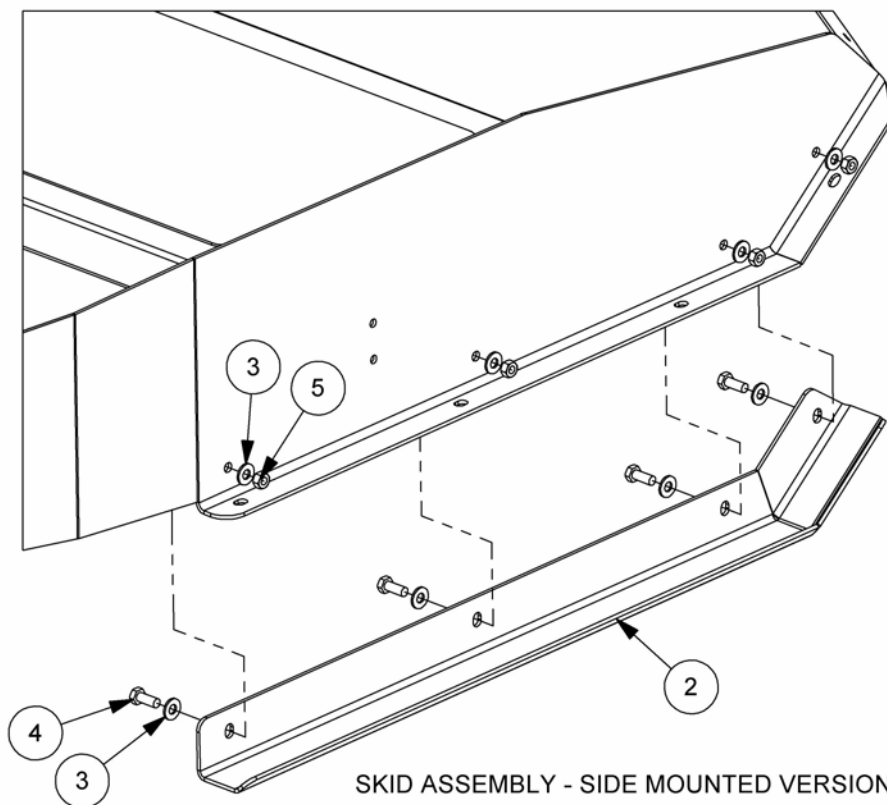
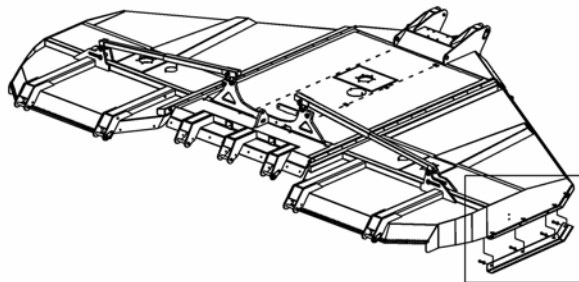

SKID ASSEMBLY - SIDE MOUNTED VERSION

REF.	QTY.	PART No.	DESCRIPTION
		1058753	SKID ASSEMBLY - SIDE MOUNTED
1	1	22147.03	WING TIP SKID - L/H SIDE MOUNTED
2	1	22147.04	WING TIP SKID - R/H SIDE MOUNTED
3	16	9100106	FLAT WASHER
4	8	9300128	SETSCREW
5	8	T8095	SELF-LOCKING NUT

Model: FW6000



SKID ASSEMBLY (Bottom Mount)

Module:
1058754

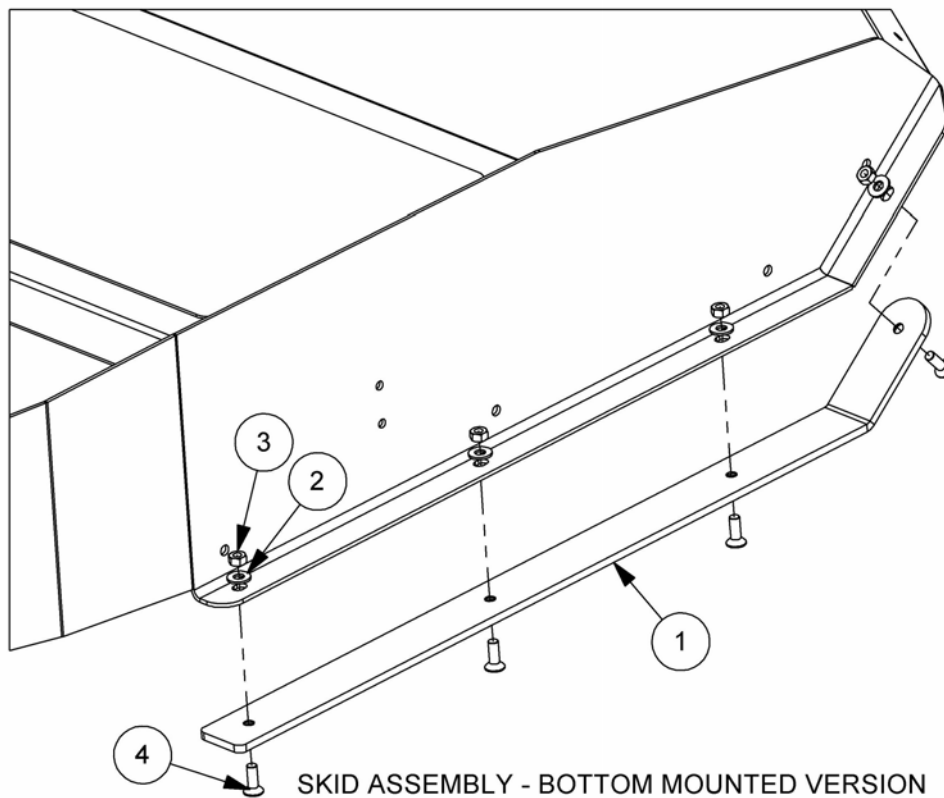
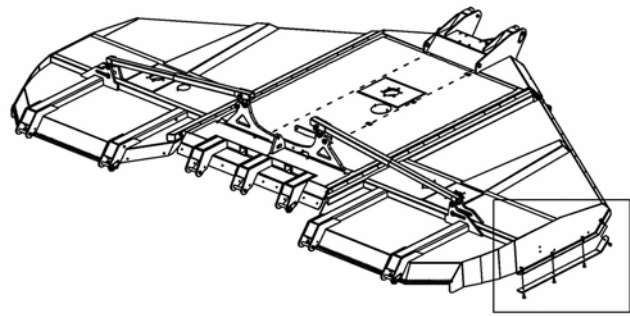

SKID ASSEMBLY - BOTTOM MOUNTED VERSION

REF.	QTY.	PART No.	DESCRIPTION
		1058754	SKID ASSEMBLY - BOTTOM MOUNTED
1	2	22218.01	WING TIP SKID - BOTTOM MOUNTED
2	8	9100106	FLAT WASHER
3	8	9143006	SELF-LOCKING NUT
4	8	9353076	CAPSCREW

BAFFLES ASSEMBLY

Module:
1058736

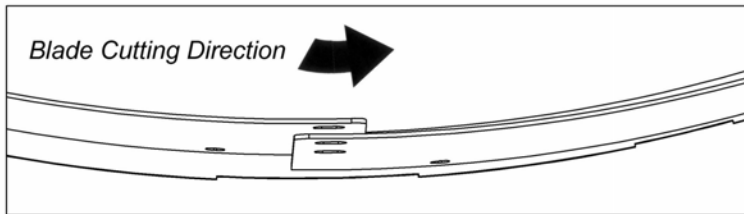
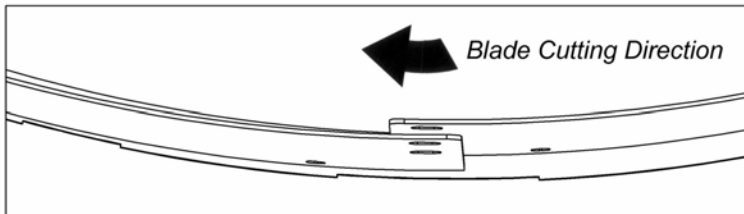
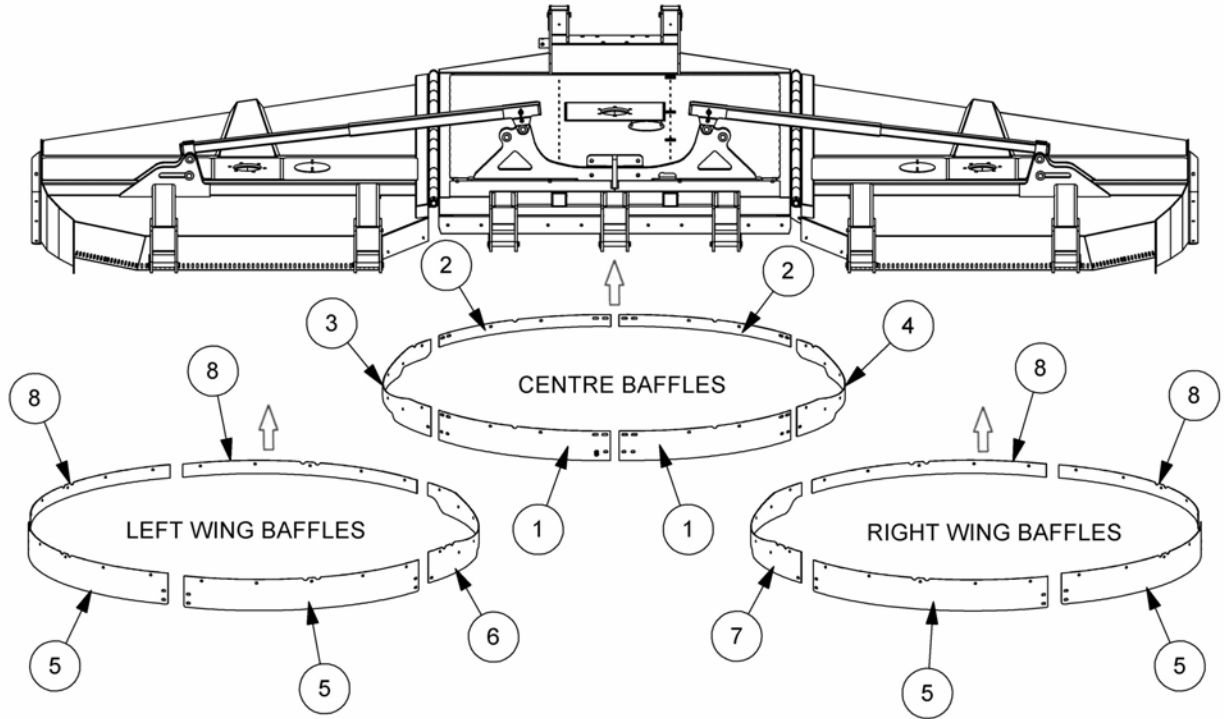

OVERLAP BAFFLES AS SHOWN IN RELATION TO BLADE ROTATION

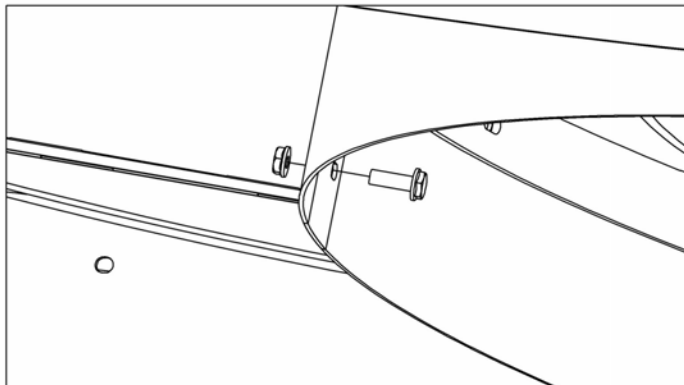

ATTACH WITH HEADS OF SETSCREWS LOCATED ON THE INNER CIRCUMFERENCE OF THE BAFFLE

BAFFLE IDENTIFICATION

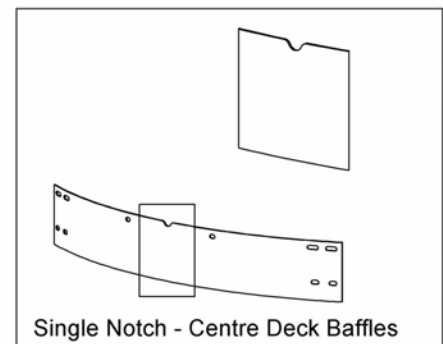

Single Notch - Centre Deck Baffles

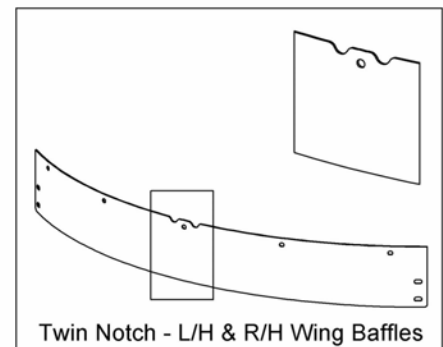

Twin Notch - L/H & R/H Wing Baffles

Model: FW6000



BAFFLES ASSEMBLY

REF.	QTY.	PART No.	DESCRIPTION
		1058736	BAFFLES ASSEMBLY
1	2	22054.05	REAR BAFFLE - CENTRE DECK
2	2	22054.08	FRONT BAFFLE - CENTRE DECK
3	1	22171.05	L/H BAFFLE - CENTRE DECK
4	1	22171.06	R/H BAFFLE - CENTRE DECK
5	4	22171.01	REAR BAFFLE - WINGS
6	1	22171.02	INNER BAFFLE - L/H WING
7	1	22171.03	INNER BAFFLE - R/H WING
8	4	22171.04	FRONT BAFFLE - WINGS
9	96	9413065	FLANGED SETSCREW & NUT

Model: FW6000

CHAIN GUARDS ASSEMBLY



Module:
1058748

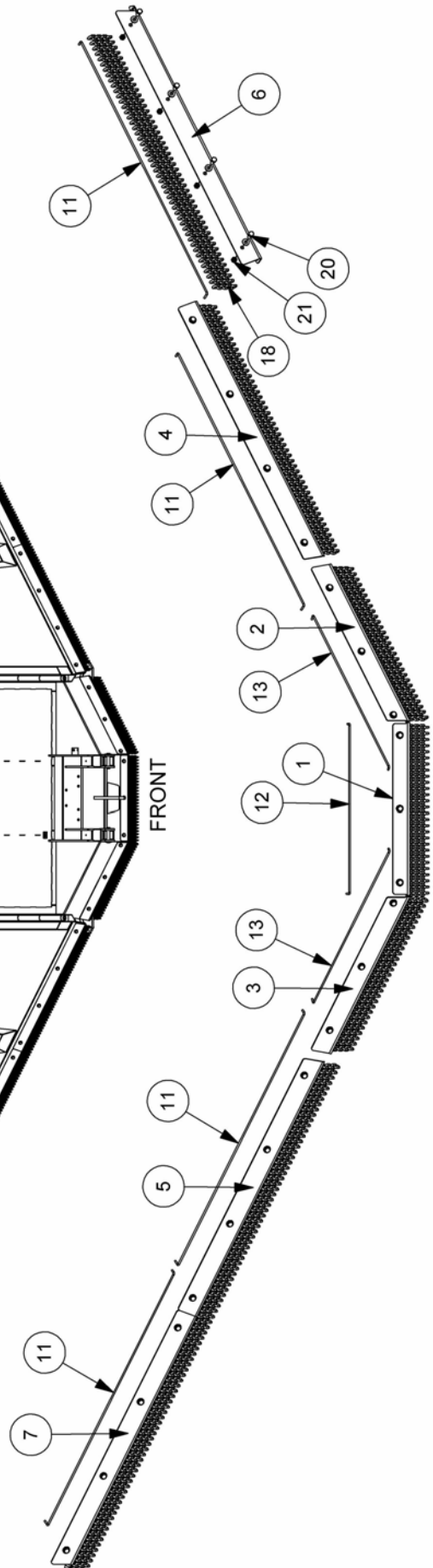
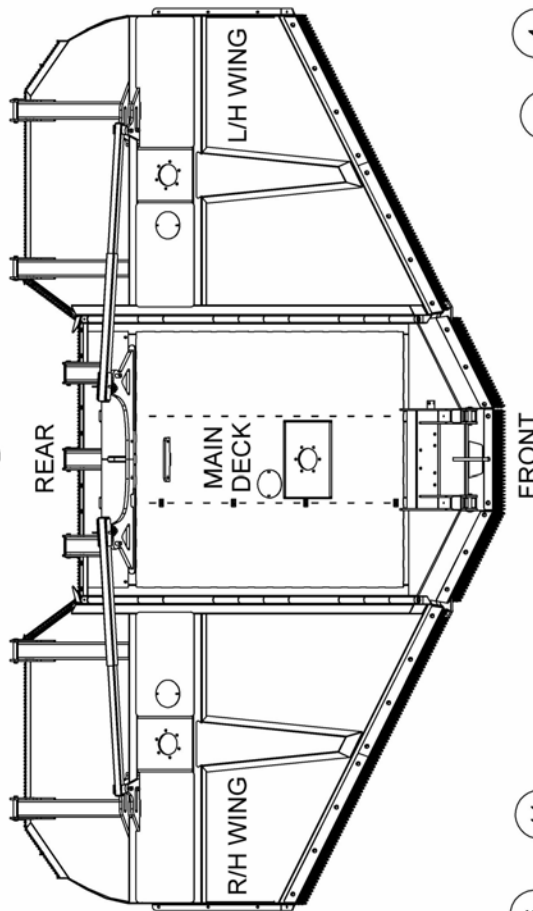
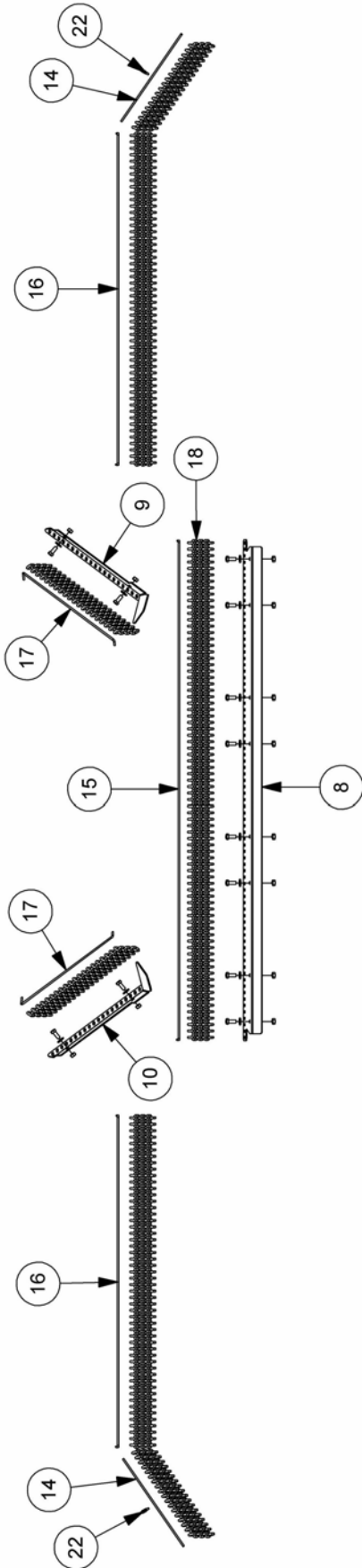

CHAIN GUARDS ASSEMBLY

REF.	QTY.	PART No.	DESCRIPTION
		1058748	CHAIN GUARDS ASSEMBLY
1	1	22140.02	GUARD - MAIN DECK CENTRE FRONT
2	1	22142.01	GUARD - MAIN DECK FRONT L/H
3	1	22142.02	GUARD - MAIN DECK FRONT R/H
4	1	22143.01	GUARD - L/H WING FRONT INBOARD
5	1	22143.02	GUARD - R/H WING FRONT INBOARD
6	1	22143.05	GUARD - L/H WING FRONT OUTBOARD
7	1	22143.06	GUARD - R/H WING FRONT OUTBOARD
8	1	22146.01	GUARD - MAIN DECK CENTRE REAR
9	1	22161.03	GUARD - L/H WING REAR INNER
10	1	22161.04	GUARD - R/H WING REAR INNER
11	4	22148.01	CHAIN RETAINING BAR - WING FRONT
12	1	22148.02	CHAIN RETAINING BAR - MAIN DECK CENTRE FRONT
13	2	22148.03	CHAIN RETAINING BAR - MAIN DECK FRONT L/H & R/H
14	2	22148.04	CHAIN RETAINING BAR - WING REAR OUTER L/H & R/H
15	1	22148.07	CHAIN RETAINING BAR - MAIN DECK REAR
16	2	22148.08	CHAIN RETAINING BAR - WING REAR CENTRE L/H & R/H
17	2	22148.09	CHAIN RETAINING BAR - WING REAR INNER L/H & R/H
18	534	46943.21	CHAIN ASSEMBLY - 7 LINK SET
19	37	9100106	FLAT WASHER
20	37	9300128	SETSCREW
21	37	T8095	SELF-LOCKING NUT
22	2	6770907	WIRE ROPE GRIP

Note: L/H & R/H references are from the Operator's perspective in the tractor cab looking forward

Model: FW6000



AXLES & WHEELS ASSEMBLY

Module:
1058756

LINK ATTACHMENT POSITIONS

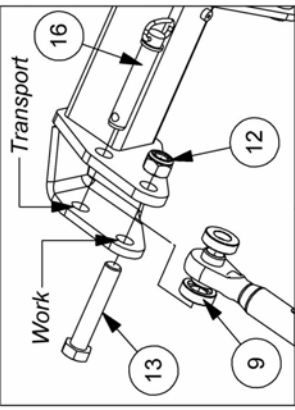

Tighten wheel nuts to 96ft.lbs (130Nm)

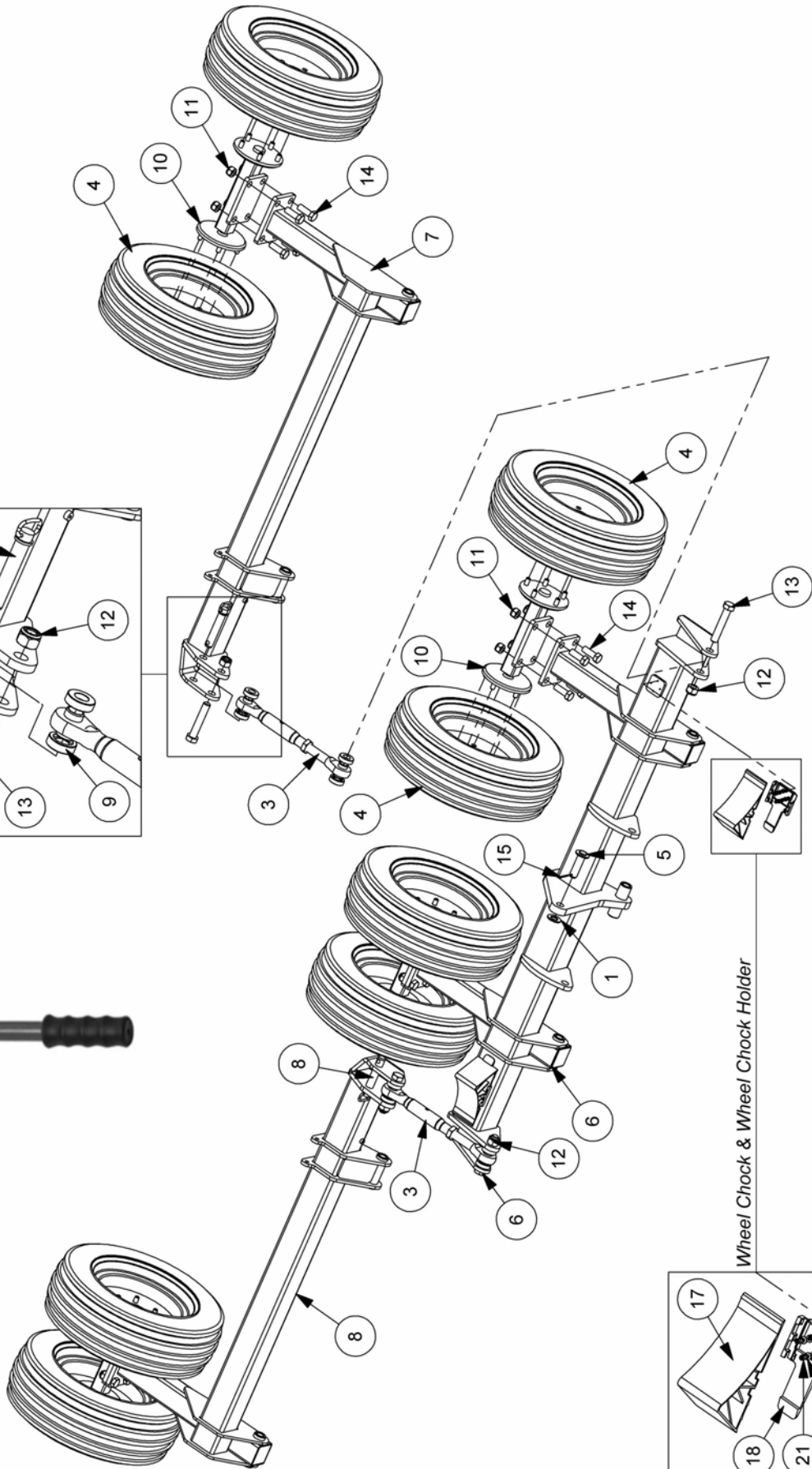

Wheel Chock & Wheel Chock Holder

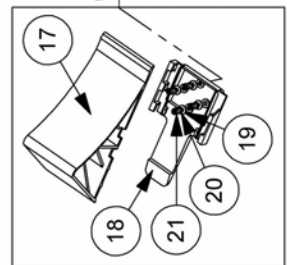

AXLES & WHEELS ASSEMBLY

REF.	QTY.	PART No.	DESCRIPTION
		1058756	AXLES & WHEELS ASSEMBLY
1	1	0100109	FLAT WASHER
2	2	0132010	NUT (THIN)
3	2	07.584.03	TOP LINK ASSEMBLY
4	8	1048038AP	WHEEL ASSEMBLY
5	1	21826.01	PIN (RAM TO AXLE)
6	1	22110.03	MAIN DECK AXLE
7	1	22111.05	AXLE - L/H WING
8	1	22111.06	AXLE - R/H WING
9	8	22137.01	AXLE LINK SPACER
10	4	46992.22	TWIN HUB
11	16	9163008	NYLOC NUT
12	4	9163009	NYLOC NUT
13	4	9213269	BOLT
14	16	9313118	SETSCREW
15	1	9501406	SPLIT PIN
16	2	22243.01	PIN c/w LINCH PIN
17	2	22247.01	WHEEL CHOCK
18	2	22247.02	WHEEL CHOCK HOLDER
19	8	9100102	FLAT WASHER
20	8	9100202	SPRING WASHER
21	8	9343022	CAPSCREW

Model: FW6000



LEVELLING SYSTEM ASSEMBLY

Module:
1058755

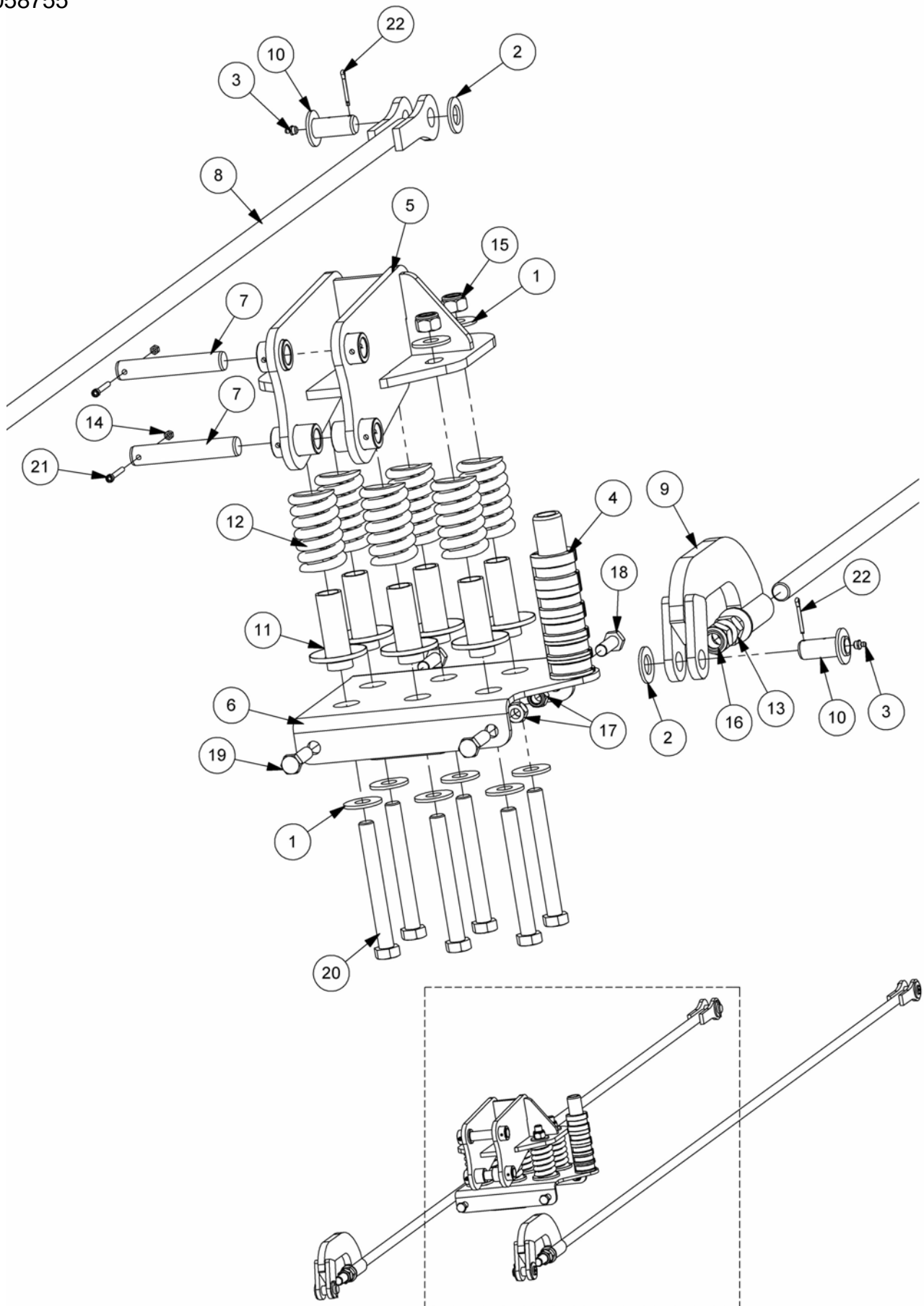



LEVELLING SYSTEM ASSEMBLY

REF.	QTY.	PART No.	DESCRIPTION
		1058755	LEVELLING BARS & SUSPENSION
1	12	00002701	FLAT WASHER
2	6	0100109	FLAT WASHER
3	4	0901161	GREASE NIPPLES
4	1	00755234	CONTROL SPACER KIT
5	1	22149.02	SUSPENSION PIVOT BRACKET
6	1	22150.02	BOTTOM SPRING MOUNTING
7	2	22157.01	PIVOT PIN
8	2	22181.01	LEVELLING BAR
9	2	22182.02	LEVELLING LINK
10	4	22238.01	PIVOT PIN
11	6	45246.01	SPRING GUIDE
12	6	45247.01	COMPRESSION SPRING
13	2	9113009	NUT
14	2	9143003	SELF-LOCKING NUT
15	6	9163008	NYLOC NUT
16	2	9163009	NYLOC NUT
17	4	T7942	NYLOC NUT
18	2	9200025	BOLT
19	2	9200031	BOLT
20	6	9213348	BOLT
21	2	9343103	CAPSCREW
22	4	9501326	SPLIT PIN

BLADE PANS & BLADES

Module:
1058740

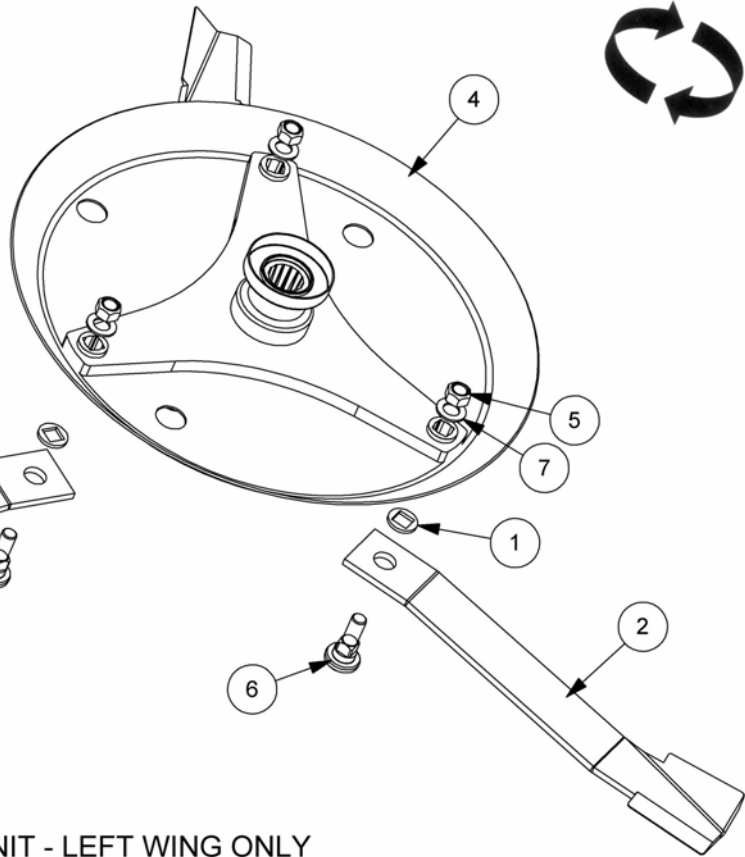
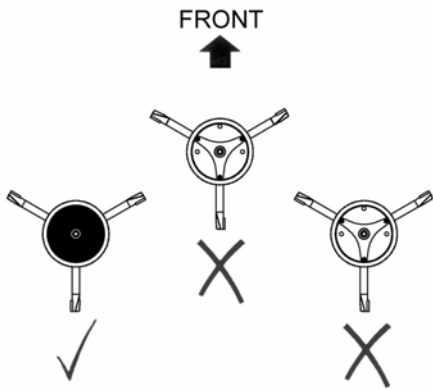

IMPORTANT: Tighten all nuts and bolts to 300ft.lbs (407Nm)

CLOCKWISE CUTTING UNIT - LEFT WING ONLY

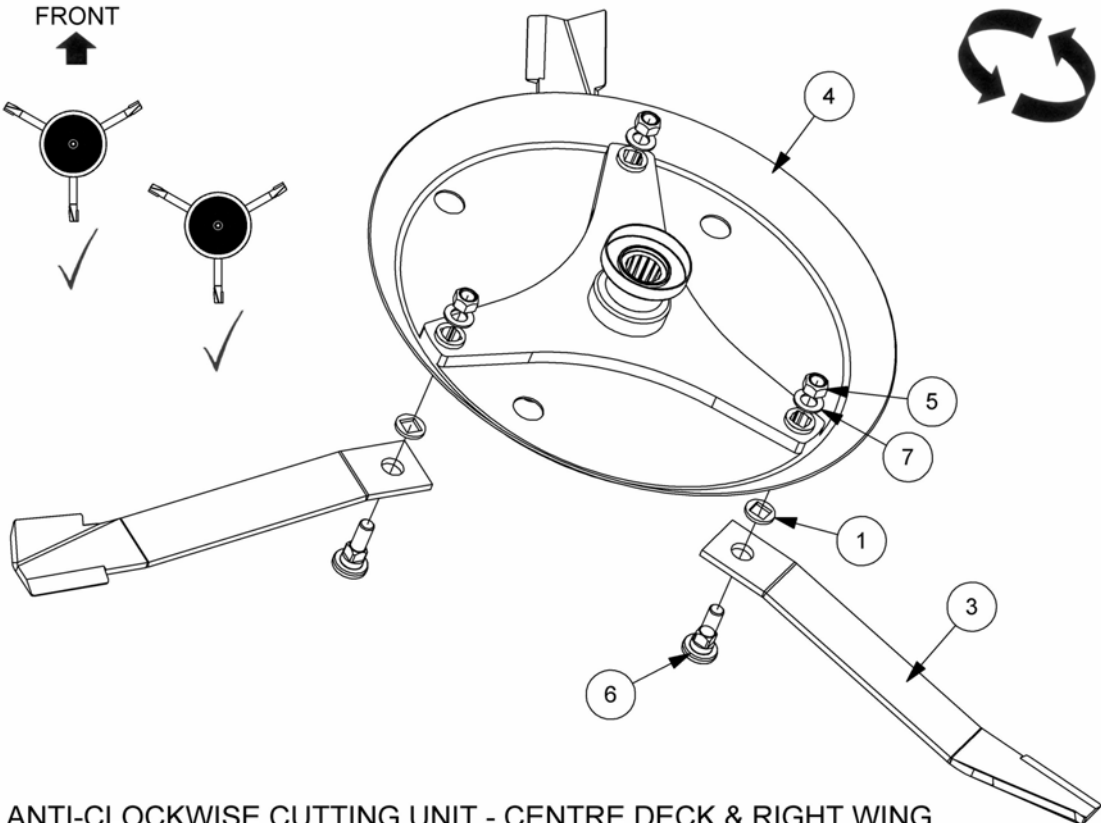
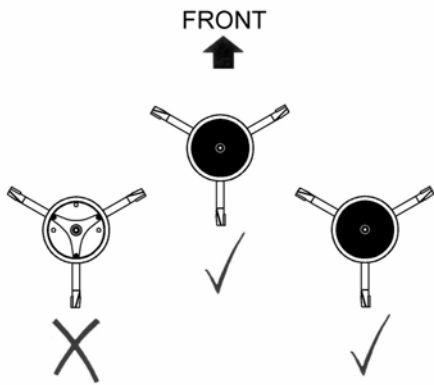

ANTI-CLOCKWISE CUTTING UNIT - CENTRE DECK & RIGHT WING

Model: FW6000



BLADE PANS & BLADES

REF.	QTY.	PART No.	DESCRIPTION
		1058740	TRI-BLADE PANS & BLADES
1	9	00758579	SPECIAL WASHER (SQUARE HOLE)
2	3	00764678	* BLADE - CLOCKWISE CUTTING
3	6	00764679	** BLADE - ANTI-CLOCKWISE CUTTING
4	3	45216.02	PAN (3 BLADE)
5	9	5JRC16140	LOCKNUT
6	9	8227	BLADE BOLT
7	9	9216	WASHER

* *Left Wing Cutting Unit*

** *Centre Deck & Right Wing Cutting Units*

SHREDDER BLADES

Module:
1058714

IMPORTANT: Tighten all nuts and bolts to 300ft.lbs (407Nm)

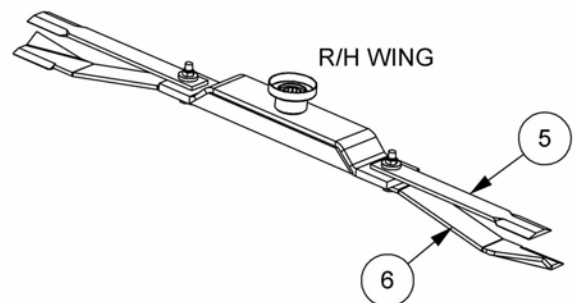
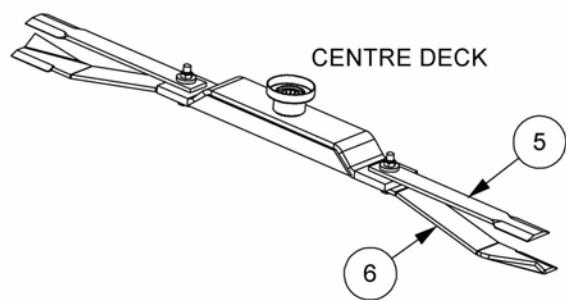
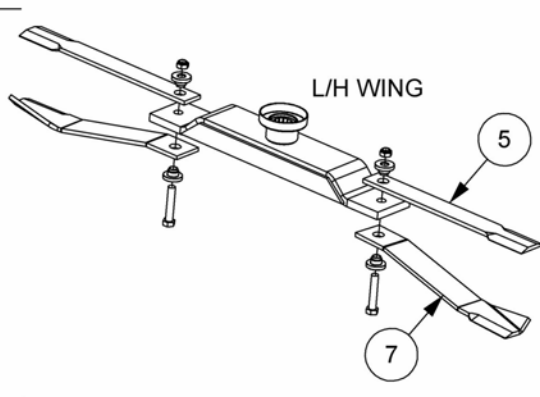
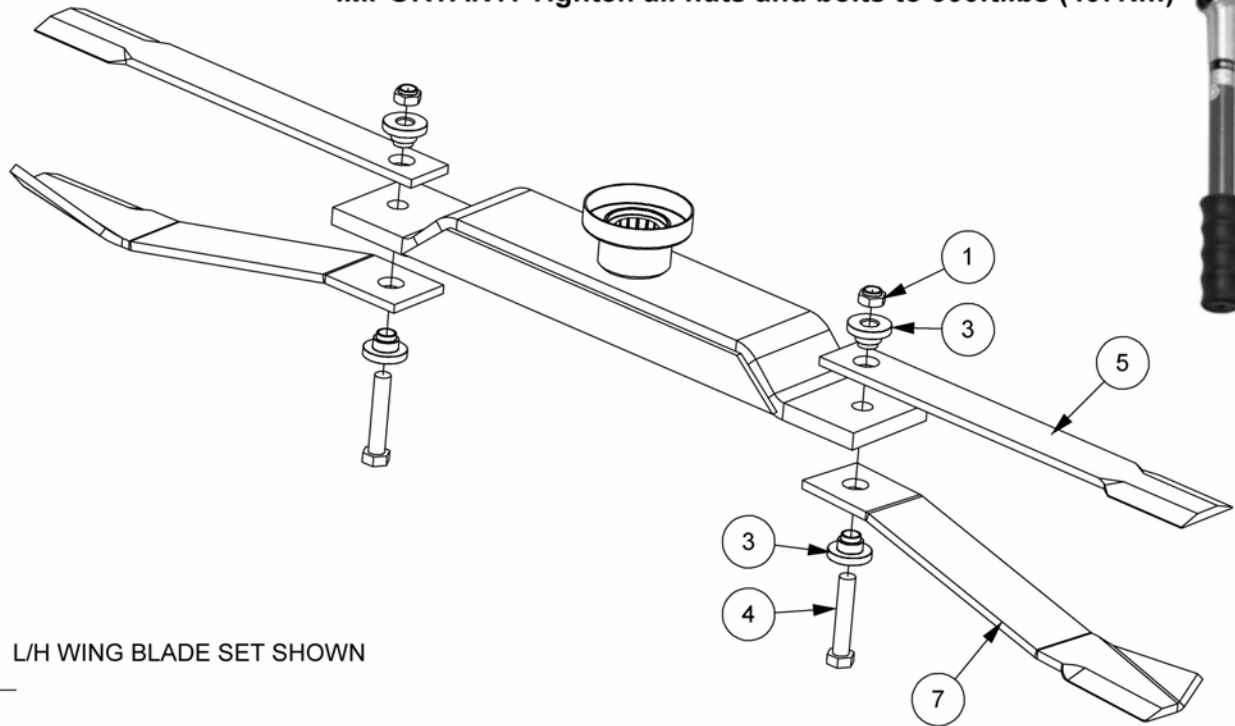



SHREDDER BLADES

REF.	QTY.	PART No.	DESCRIPTION
		1058714	SHREDDER BLADES ASSEMBLY
1	6	00750226	LOCKNUT
2	3	00767554	BLADE BAR
3	12	0811230060	BLADE BUSHING
4	6	7AH8141436	BLADE BOLT
5	6	00779129	SHREDDER BLADE
6	4	0582010330	** BLADE - ANTI-CLOCKWISE CUTTING
7	2	0582010332	* BLADE - CLOCKWISE CUTTING

* *Left Wing Cutting Unit*
 ** *Centre Deck & Right Wing Cutting Units*

Module:
1058733

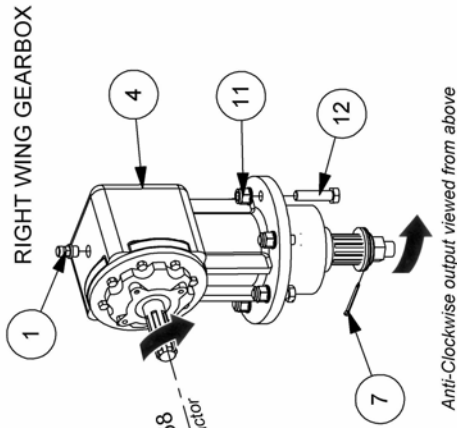

SHAFT: 00756633A or 1058258
Clockwise rotation when viewed from tractor

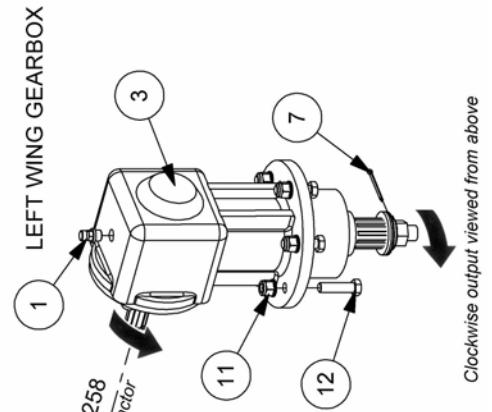

SHAFT: 00756633A or 1058258
Clockwise rotation when viewed from tractor

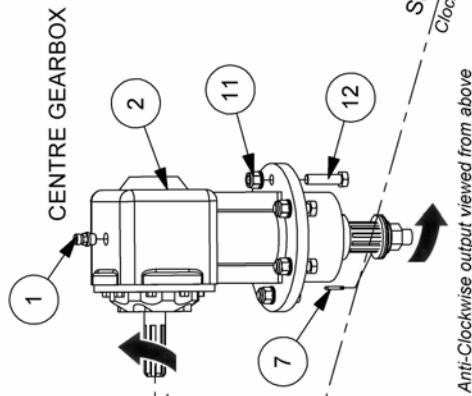

SHAFT: 00756634ACE or 1058259
Anti-Clockwise rotation when viewed from tractor

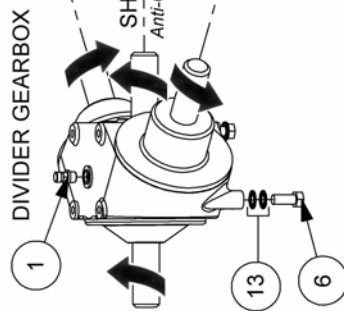
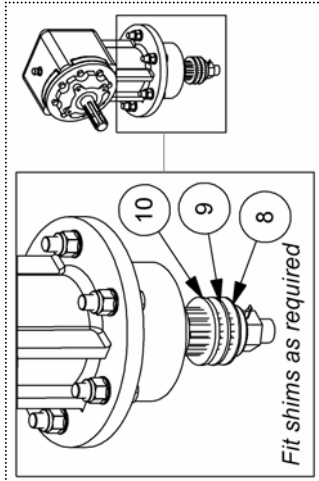

TORQUE SETTINGS:

Divider Gearbox Bolts (Item 6) = 153 lbf-ft / 207 Nm

Deck Gearbox Nuts (Item 11) = 174 lbf-ft / 236 Nm

Blade Pan Retaining Nuts = 450 lbf-ft / 610 Nm & secure with cotter pin in slots of nut (shim as required)



GEARBOXES & DRIVESHAFTS

REF.	QTY.	PART No.	DESCRIPTION
		1058733	GEARBOXES MODULE
1	4	00762114	BREATHER
2	1	00769930	GEARBOX (CENTRE) - RATIO 1.46:1
3	1	00769927P	GEARBOX (L/H WING) - RATIO 1.21:1
4	1	00769924P	GEARBOX (R/H WING) - RATIO 1.21:1
5	1	00769116P	DIVIDER GEARBOX
6	6	0312126	HEX SCREW
7	3	0503205	COTTER PIN
8	3	22165.01	BLADE PAN SHIM - 2MM
9	3	22165.02	BLADE PAN SHIM - 3MM
10	3	22165.03	BLADE PAN SHIM - 5MM
11	18	9100024	SELF-LOCKING FLANGE NUT
12	18	9200031	BOLT
13	6	B001017	NORDLOCK WASHER (2 part)
		1058738	DRIVESHAFTS MODULE - EG
14	*	1	00756634ACE SHAFT - DIVIDER TO CENTRE GEARBOXES
15	*	2	00756633A SHAFT - DIVIDER TO WING GEARBOXES
		1058739	DRIVESHAFTS MODULE - Walterscheid
14	*	1	1058259 SHAFT - DIVIDER TO CENTRE GEARBOXES
15	*	2	1058258 SHAFT - DIVIDER TO WING GEARBOXES

* *Not Illustrated*

Model: FW6000

DIVIDER GEARBOX (1000 rpm)



Module:
00769116P

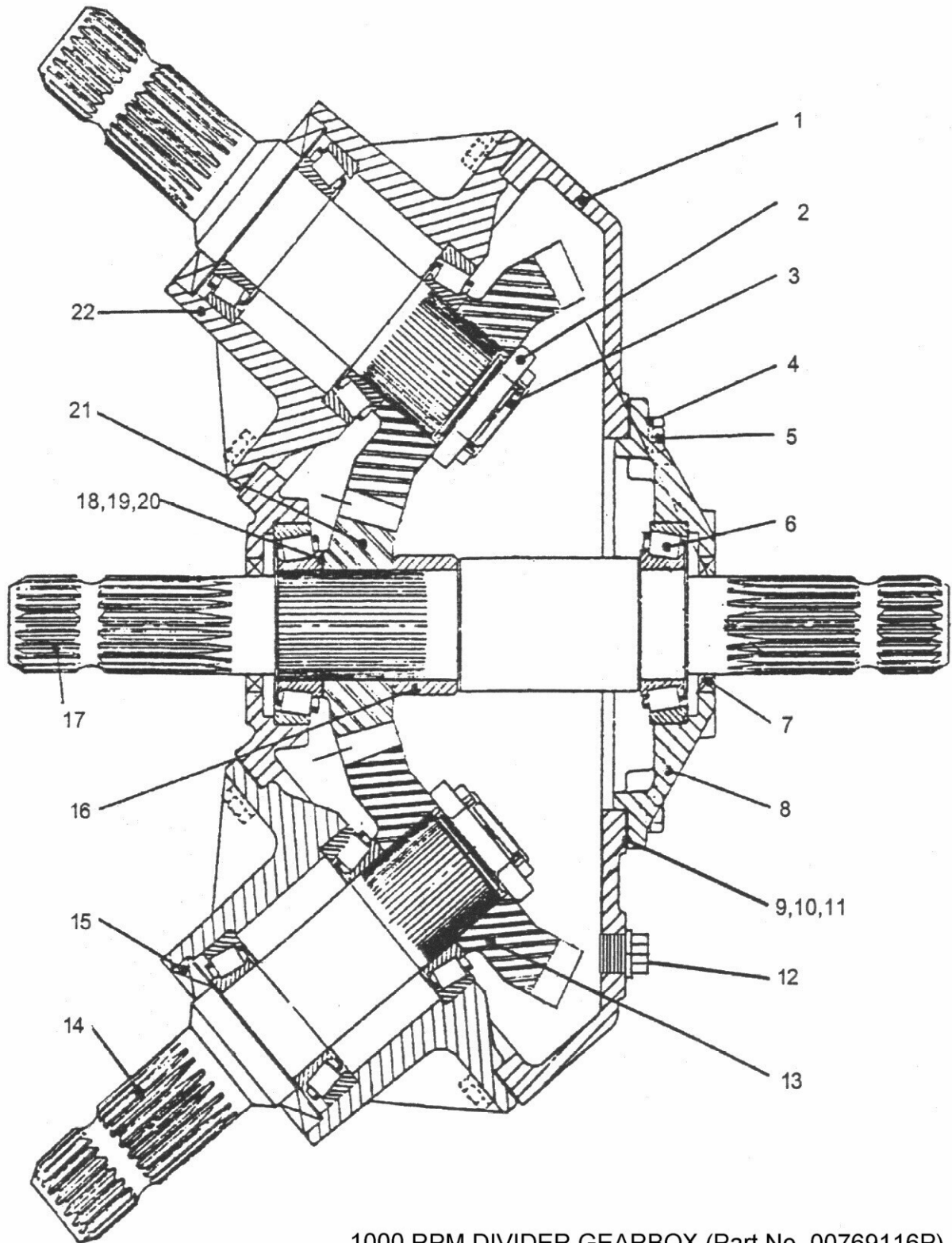

1000 RPM DIVIDER GEARBOX (Part No. 00769116P)

DIVIDER GEARBOX (1000 rpm)

REF.	QTY.	PART No.	DESCRIPTION
		00769116	DIVIDER GEARBOX ASSEMBLY (1000 RPM)
1	1	00769162	DIVIDER GEARBOX HOUSING
2	2	00762121	SLOTTED NUT
3	2	00026200	COTTER PIN
4	24	00755954	LOCKWASHER
5	24	00758659	BOLT
6	6	00755628	BEARING
7	2	00758653	SEAL
8	1	00762128	INPUT CAP
9	<i>as req'd</i>	00758646	SHIM (ADJUSTMENT 0.1)
10	<i>as req'd</i>	00758647	SHIM (ADJUSTMENT 0.25)
11	<i>as req'd</i>	00758648	SHIM (ADJUSTMENT 0.5)
12	1	00762123	LEVEL PLUG
13	2	00769159	GEAR (26 TOOTH)
14	2	00762522	SIDE INPUT SHAFT
15	2	00762521	SEAL
16	1	00758657	SPACER - INPUT SHAFT
17	1	00769163	MAIN INPUT SHAFT
18	<i>as req'd</i>	00758667	SHIM (ADJUSTMENT 0.3)
19	<i>as req'd</i>	00758666	SHIM (ADJUSTMENT 0.4)
20	<i>as req'd</i>	00758668	SHIM (ADJUSTMENT 0.4)
21	1	00769158	GEAR (20 TOOTH)
22	2	00762520	HORZ. HUB CAP
23	1	00762114	PIPE PLUG - VENTED (<i>not illustrated</i>)

Model: FW6000

CENTRE GEARBOX (1000 rpm)



Module:
00769930

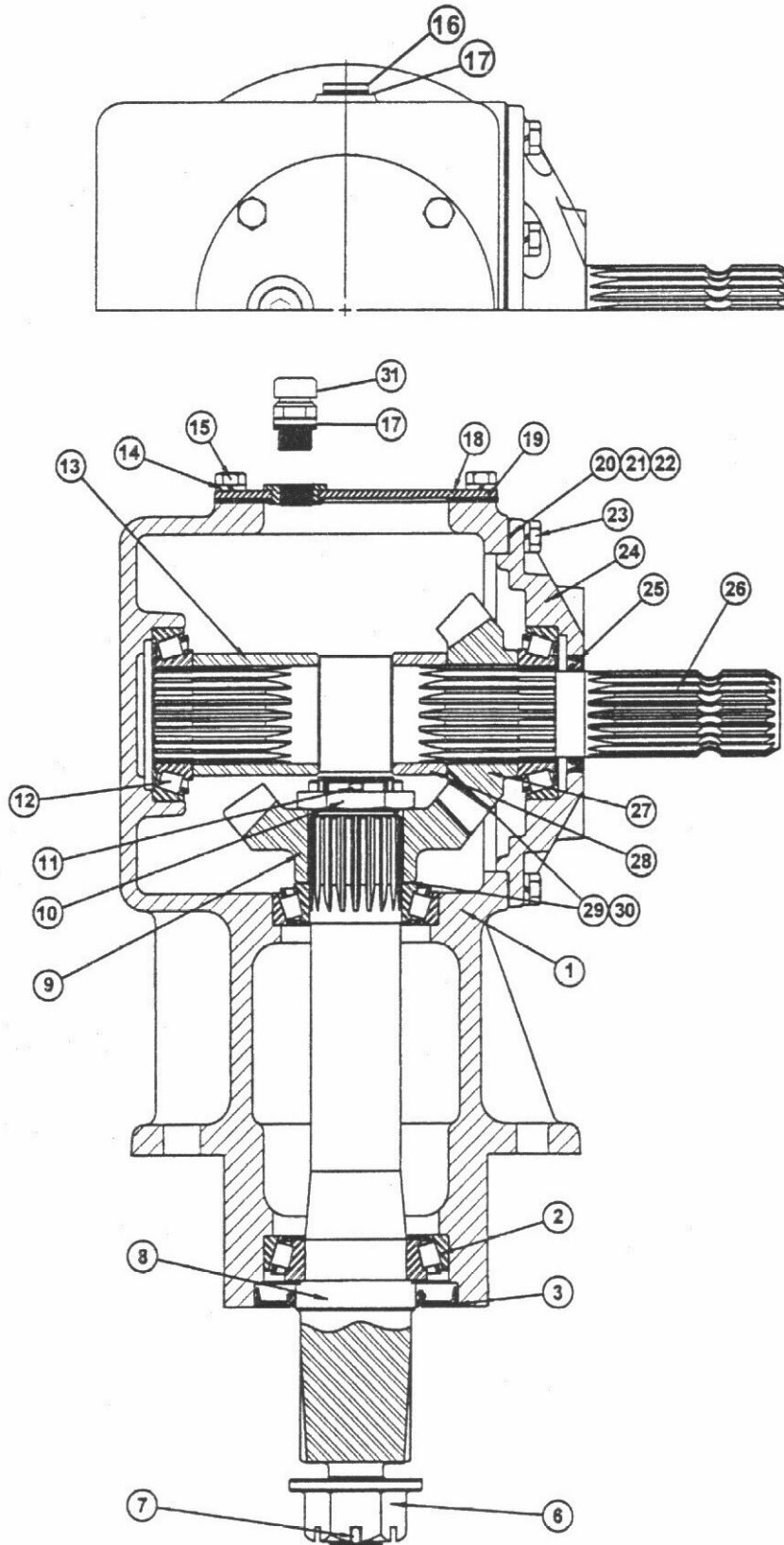

1000 RPM CENTRE GEARBOX (Part No. 00769930)

CENTRE GEARBOX (1000 rpm)

REF.	QTY.	PART No.	DESCRIPTION
		00769930	CENTRE GEARBOX ASSEMBLY (1000 RPM)
1	1	00770724	HOUSING
2	1	00770725	BEARING ASSEMBLY
3	1	00770726	OIL SEAL
6	1	00771226	FLANGE NUT SLOT
7	1	01422502	COTTER PIN
8	1	00770725	VERTICAL OUTPUT SHAFT
9	1	00770729	GEAR (19 TOOTH)
10	1	00762121	NUT
11	1	00606000	COTTER PIN
12	3	00755628	BEARING ASSEMBLY
13	1	00770731	INPUT SHAFT SPACER (SHORT)
14	12	00766083	LOCKWASHER
15	4	00754338	BOLT
16	1	00762517	PLUG
17	2	00769321	SEALING WASHER
18	1	00770732	INSPECTION COVER
19	1	00770733	INSPECTION COVER GASKET
20	<i>as req'd</i>	00758646	SHIM (ADJUSTMENT 0.10)
21	<i>as req'd</i>	00758647	SHIM (ADJUSTMENT 0.25)
22	<i>as req'd</i>	00758648	SHIM (ADJUSTMENT 0.50)
23	8	00765905	BOLT
24	1	00770734	INPUT CAP
25	1	00758653	SEAL
26	1	00770735	INPUT SHAFT
27	1	00770736	13 TOOTH PINION
28	1	00758657	INPUT SHAFT SPACER (LONG)
29	<i>as req'd</i>	00758667	SHIM (ADJUSTMENT 0.30)
30	<i>as req'd</i>	00758668	SHIM (ADJUSTMENT 0.50)
31	1	00762114	PLUG VENT

Model: FW6000

L/H WING GEARBOX (1000 rpm)



Module:
00769927P

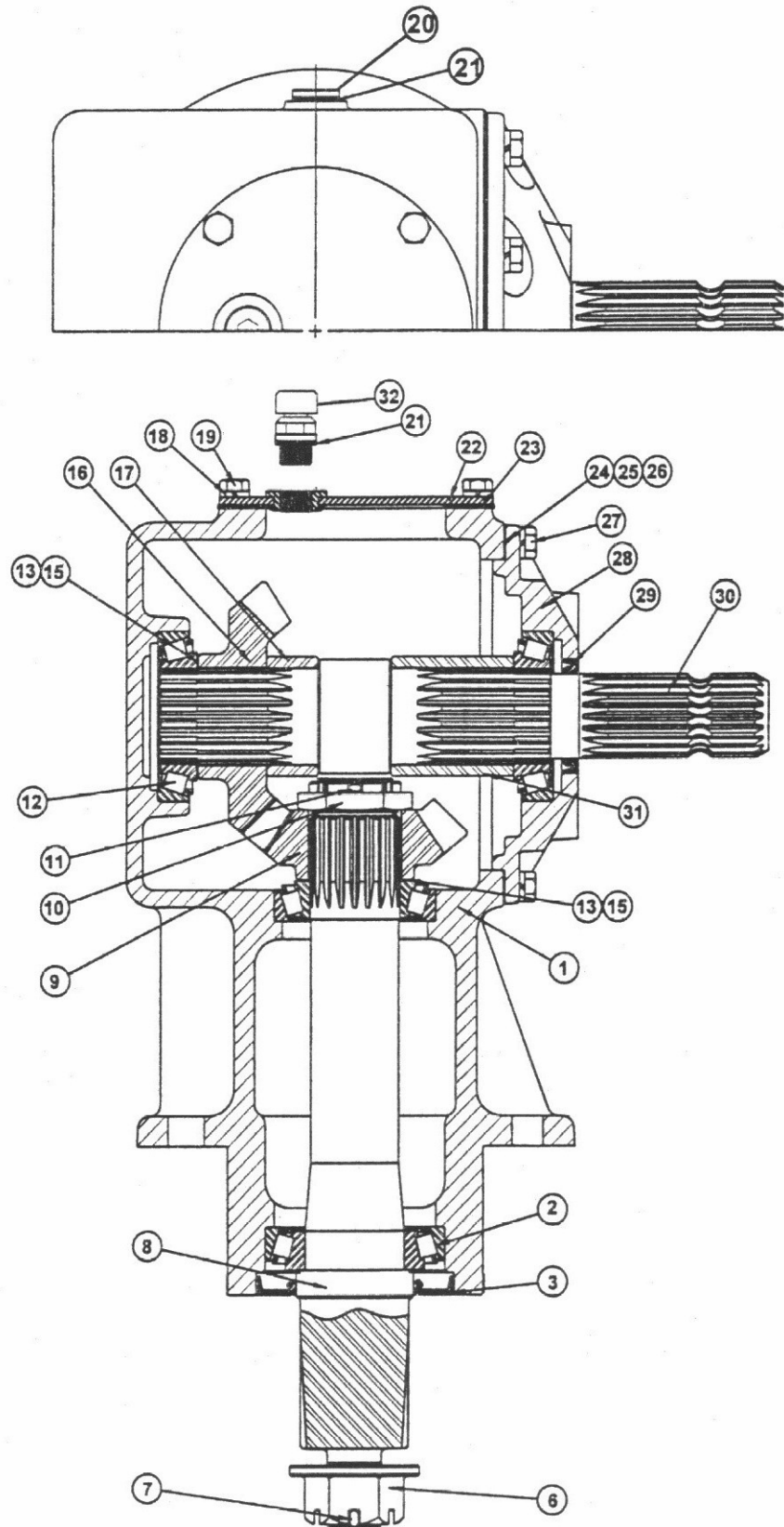

1000 RPM L/H WING GEARBOX (Part No. 00769927P)

L/H WING GEARBOX (1000 rpm)

REF.	QTY.	PART No.	DESCRIPTION
		00769927P	L/H WING GEARBOX ASSEMBLY (1000 RPM)
1	1	00770724	HOUSING
2	1	00770725	BEARING ASSEMBLY
3	1	00770726	OIL SEAL
6	1	00771226	FLANGE NUT SLOT
7	1	01422502	COTTER PIN
8	1	00770728	VERTICAL OUTPUT SHAFT
9	1	00770739	GEAR (17 TOOTH)
10	1	00762121	NUT
11	1	00606000	COTTER PIN
12	3	00755628	BEARING ASSEMBLY
13	<i>as req'd</i>	00758667	SHIM (ADJUSTMENT 0.30)
15	<i>as req'd</i>	00758668	SHIM (ADJUSTMENT 0.50)
16	1	00770738	GEAR (14 TOOTH)
17	1	00758657	INPUT SHAFT SPACER (LONG)
18	12	00766083	LOCKWASHER
19	4	00754338	BOLT
20	1	00762517	PLUG SOCKET HEAD
21	2	00769321	SEALING WASHER
22	1	00770732	INSPECTION COVER
23	1	00770733	INSPECTION COVER GASKET
24	<i>as req'd</i>	00758646	SHIM (ADJUSTMENT 0.10)
25	<i>as req'd</i>	00758647	SHIM (ADJUSTMENT 0.25)
26	<i>as req'd</i>	00758648	SHIM (ADJUSTMENT 0.50)
27	8	00765905	BOLT
28	1	00770734	INPUT CAP
29	1	00758653	OIL SEAL
30	1	00770735	INPUT SHAFT
31	1	00770731	INPUT SHAFT SPACER (SHORT)
32	1	00762114	PLUG VENT

Model: FW6000

R/H WING GEARBOX (1000 rpm)



Module:
00769924P

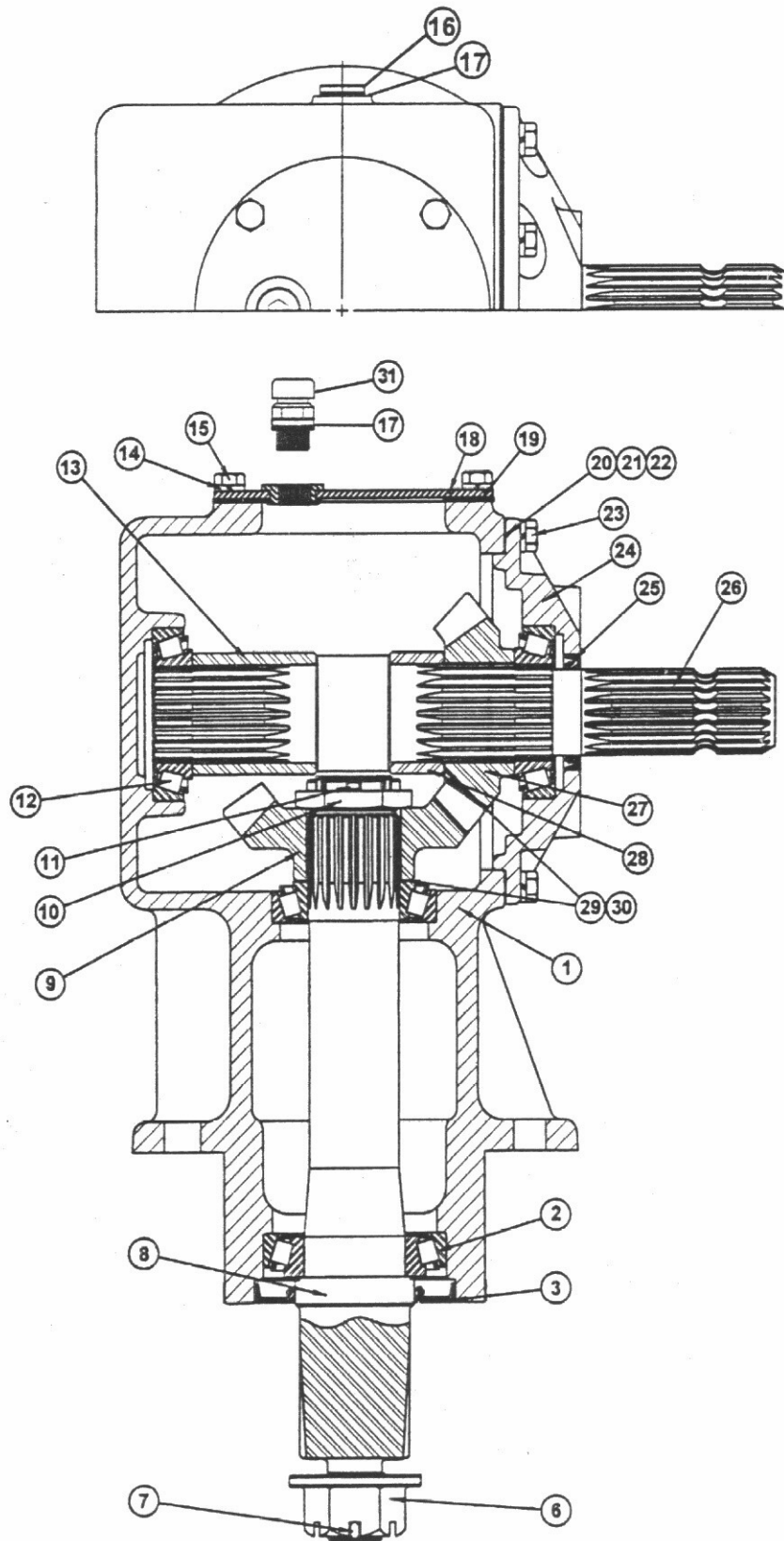

1000 RPM R/H WING GEARBOX (Part No. 00769924P)

R/H WING GEARBOX (1000 rpm)

REF.	QTY.	PART No.	DESCRIPTION
		00769924P	R/H WING GEARBOX ASSEMBLY (1000 RPM)
1	1	00770724	HOUSING
2	1	00770725	BEARING ASSEMBLY
3	1	00770726	OIL SEAL
6	1	00771226	FLANGE NUT SLOT
7	1	01422502	COTTER PIN
8	1	00770728	VERTICAL OUTPUT SHAFT
9	1	00770739	GEAR (17 TOOTH)
10	1	00762121	NUT
11	1	00606000	COTTER PIN
12	3	00755628	BEARING ASSEMBLY
13	1	00770731	INPUT SHAFT SPACER (SHORT)
14	12	00766083	LOCKWASHER
15	4	00754338	BOLT
16	1	00762517	PLUG SOCKET HEAD
17	2	00769321	SEALING WASHER
18	1	00770732	INSPECTION COVER
19	1	00770733	INSPECTION COVER GASKET
20	<i>as req'd</i>	00758646	SHIM (ADJUSTMENT 0.10)
21	<i>as req'd</i>	00758647	SHIM (ADJUSTMENT 0.25)
22	<i>as req'd</i>	00758648	SHIM (ADJUSTMENT 0.50)
23	8	00765905	BOLT
24	1	00770734	INPUT CAP
25	1	00758653	SEAL
26	1	00770735	INPUT SHAFT
27	1	00770738	14 TOOTH PINION
28	1	00758657	INPUT SHAFT SPACER (LONG)
29	<i>as req'd</i>	00758667	SHIM (ADJUSTMENT 0.30)
31	<i>as req'd</i>	00758668	SHIM (ADJUSTMENT 0.50)
32	1	00762114	PLUG VENT

Model: FW6000



DRIVESHAFT - CENTRE GEARBOX

Module:
00756634ACE

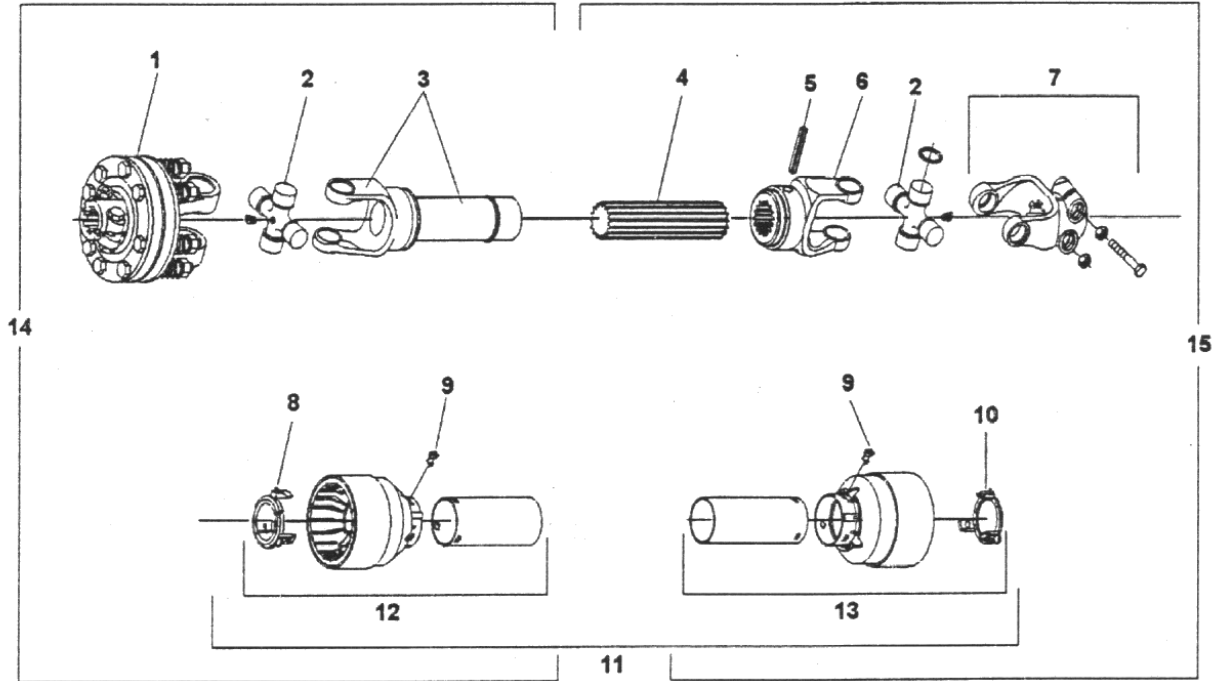

REF.	QTY.	PART No.	DESCRIPTION
		00756634ACE	DRIVESHAFT (CENTRE GEARBOX)
1	1	00756173	SLIP CLUTCH
2	2	00753068	CROSS JOURNAL SET
3	1	00772269	YOKE WITH SLEEVE ASSEMBLY
4	1	00756651	SPLINED SHAFT
5	1	00758159	ROLL PIN
6	1	00766585	INNER YOKE
7	1	00772743	COMPLETE INTERFERING CLAMP BOLT YOKE 165
8	1	00765420	GUARD RETAINING COLLAR FOR INNER TUBE
9	6	00754330	BOLT
10	1	00765417	RETAINING COLLAR FOR INNER TUBE
11	1	00765463	COMPLETE GUARD c/w INSTRUCTION MANUAL
12	1	00765461	HALF FEMALE GUARD
13	1	00765462	HALF MALE GUARD
14	1	00765459	HALF FEMALE SHAFT c/w GUARDING
15	1	00765460	HALF MALE SHAFT c/w GUARDING

DRIVESHAFT - WING GEARBOXES

Module:
00756633A

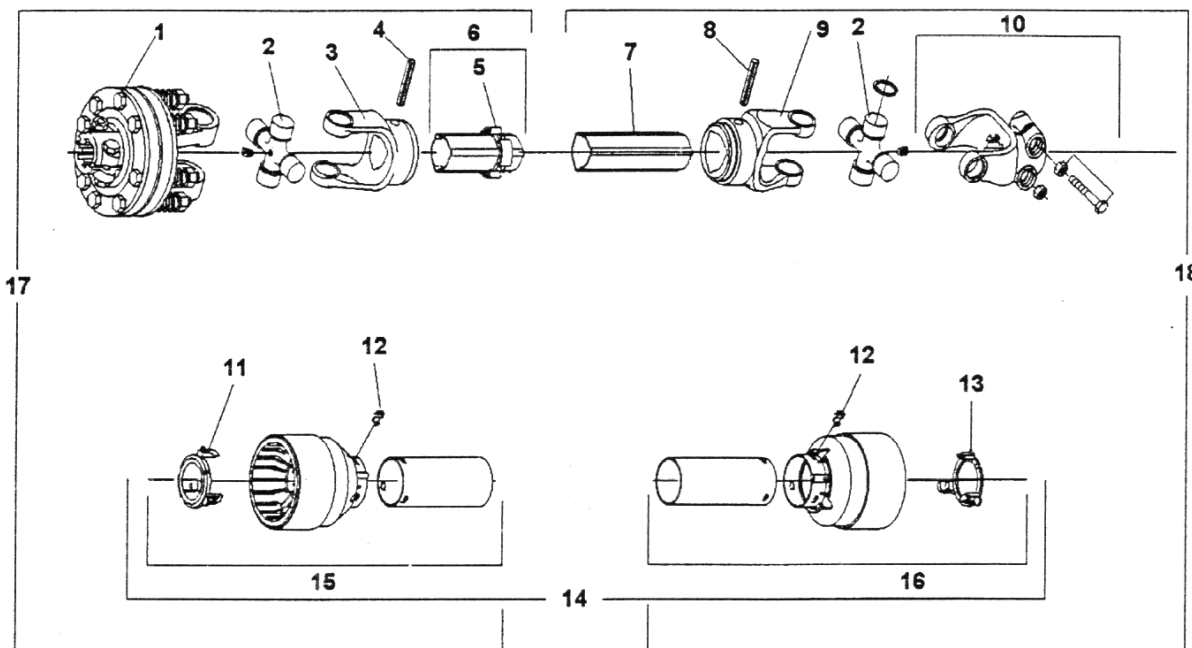

REF.	QTY.	PART No.	DESCRIPTION
		00756633A	DRIVESHAFT (WING GEARBOXES)
1	1	00756173	SLIP CLUTCH c/w SPRING
2	2	00753068	CROSS JOURNAL SET
3	1	00765471	OUTER YOKE
4	1	00766934	ROLL PIN FOR OUTER TUBE
5	1	00772932	BUSH c/w GREASE NIPPLE
6	1	00765466	COMPLETE OUTER TUBE
7	1	00765465	INNER TUBE
8	1	00756934	ROLL PIN FOR INNER TUBE
9	1	00765472	INNER YOKE
10	1	00757040	COMPLETE INTERFERING CLAMP BOLT YOKE 165
11	1	00765420	GUARD RETAINING COLLAR FOR OUTER TUBE
12	6	00754330	BOLT
13	1	00765417	GUARD RETAINING COLLAR FOR INNER TUBE
14	1	00765448	COMPLETE GUARD c/w INSTRUCTION MANUAL
15	1	00765438	HALF FEMALE GUARD
16	1	00765439	HALF MALE GUARD
17	1	00765447	HALF FEMALE SHAFT c/w GUARDING
18	1	00765446	HALF MALE SHAFT c/w GUARDING

SLIP CLUTCH ASSEMBLY

Module:
00756173

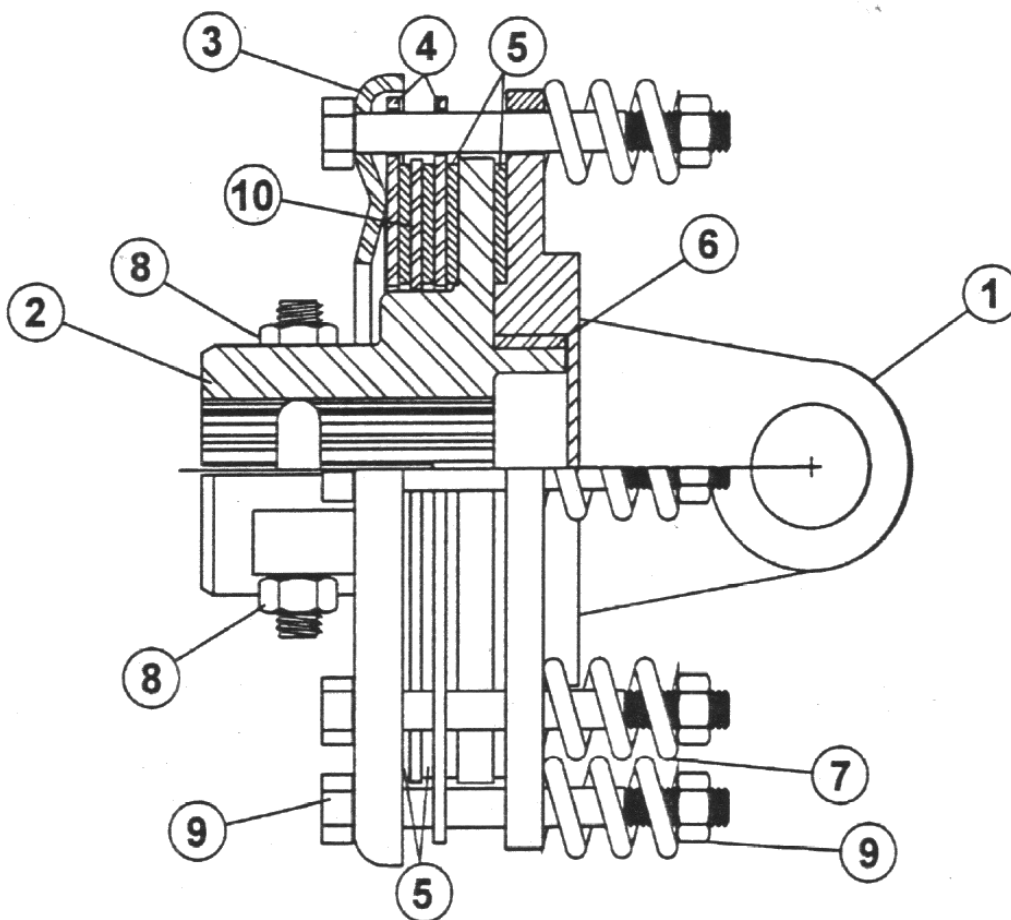

For Cat. 5 Drivelines

REF.	QTY.	PART No.	DESCRIPTION
		00756173	SLIP CLUTCH ASSEMBLY
1	1	00754083	YOKE - CLUTCH SERIES 8
2	1	00755599	CLUTCH SUPPORT
3	1	00768810	PRESSURE PLATE
4	2	00754314	PLATE WITH HOLES
5	4	00754202	CLUTCH LINING RING
6	1	00754301	BUSHING
7	8	00754303	SPRING CLUTCH
8	2	00755600	NUT & BOLT
9	8	00754199	NUT & BOLT
	8		NUT & BOLT
10	1	00754201	INTERMEDIATE PLATE

This page is intentionally blank

DRIVESHAFT GUARDS

Module:
1058749

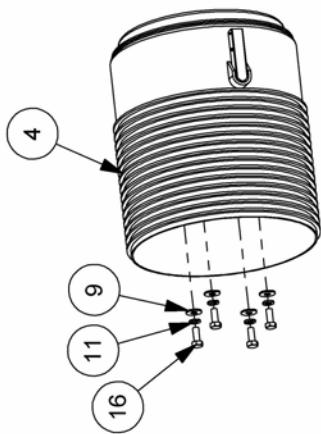

PTO GUARD - RIGHT WING DRIVESHAFT

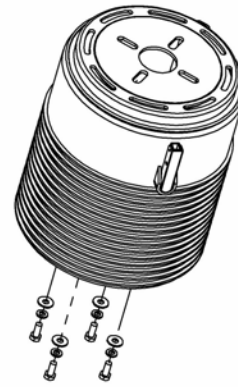

PTO GUARD - LEFT WING DRIVESHAFT

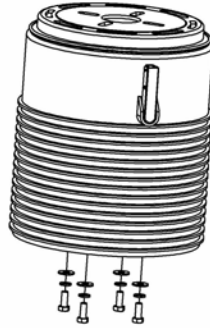

PTO GUARD - CENTRE DRIVESHAFT

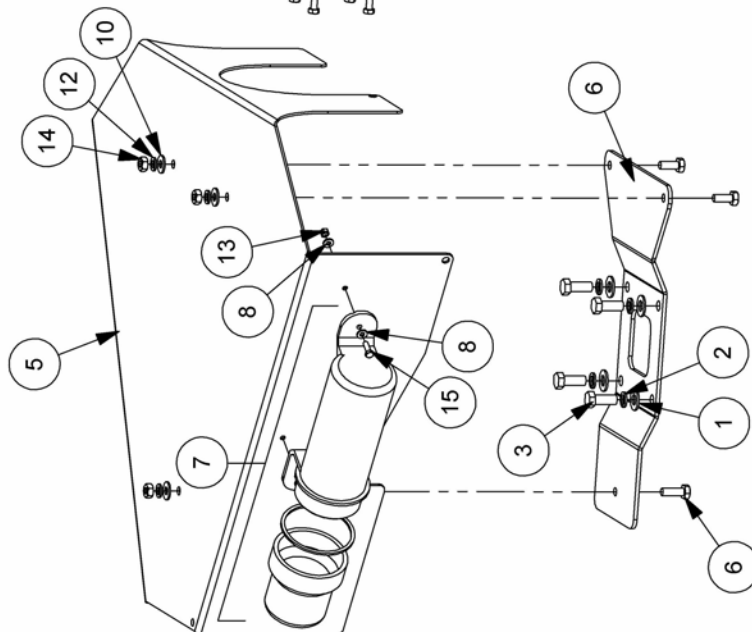



DRIVESHAFT GUARDS

REF.	QTY.	PART No.	DESCRIPTION
		1058749	DRIVESHAFT GUARDS
1	4	0100105	FLAT WASHER
2	4	0100205	SPRING WASHER
3	4	02030700	HEX SCREW
4	3	21839.01	PTO GUARD
5	1	22183.02	DIVIDER GEARBOX COVER
6	1	22233.01	COVER MOUNTING
7	1	46505.01	LITERATURE HOLDER
8	6	9100103	FLAT WASHER
9	12	9100104	FLAT WASHER
10	3	9100105	FLAT WASHER
11	12	9100204	SPRING WASHER
12	3	9100205	SPRING WASHER
13	3	9143003	SELF-LOCKING NUT
14	3	9113005	PLAIN NUT
15	3	9313043	SETSCREW
16	12	9313044	SETSCREW

Model: FW6000



AXLE RAM ASSEMBLY

Module:
00761802

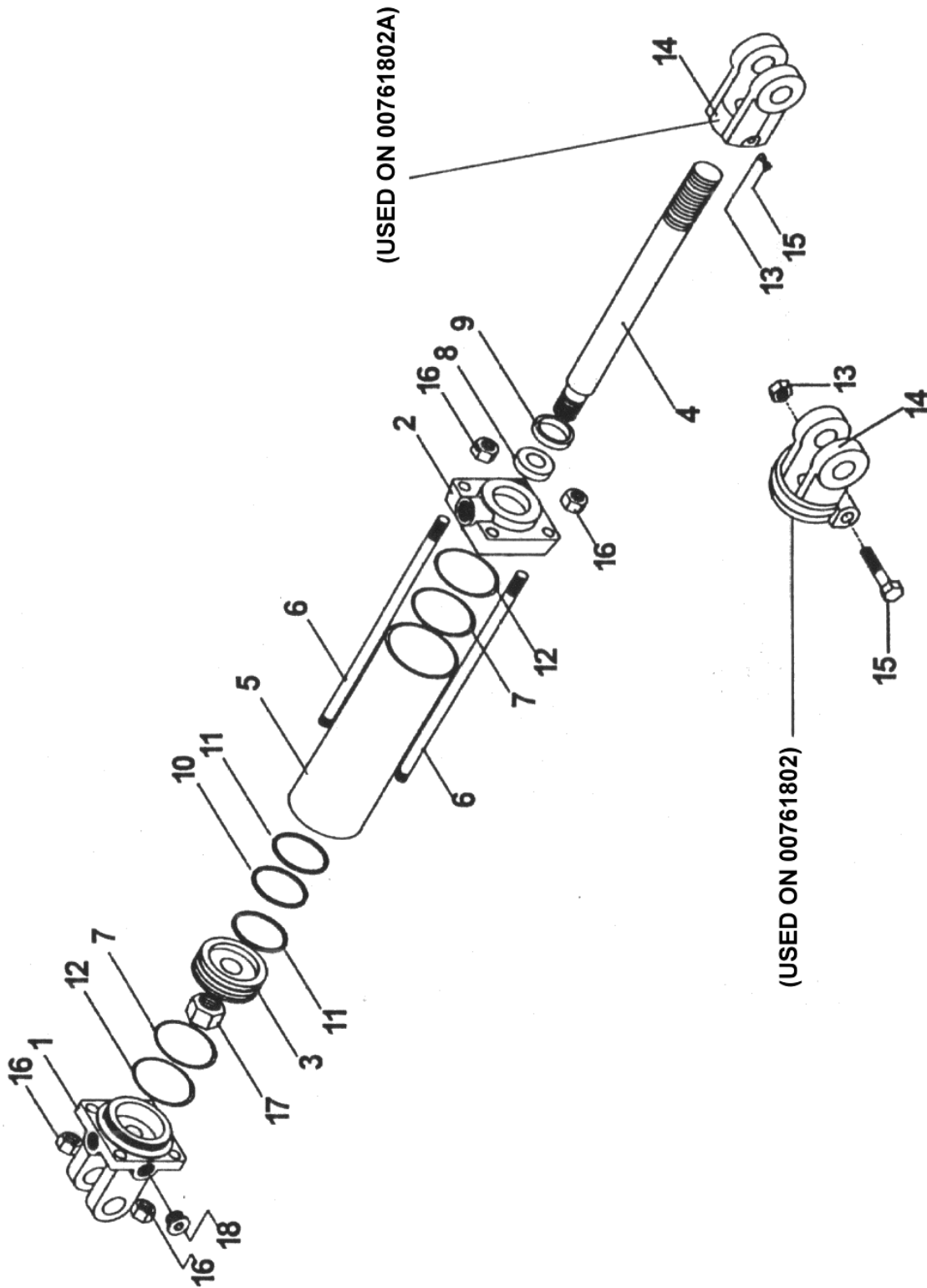

AXLE RAM ASSEMBLY

REF.	QTY.	PART No.	DESCRIPTION
		00761802	CYLINDER ASSEMBLY
1	1	8772	CAP
2	1	00761896	HEAD
3	1	00761892	PISTON
4	1	00761894	PISTON ROD
5	1	00761893	TUBE
6	4	8773	TIE ROD
13	1	00015800	NUT
14	1	00761895	CLEVIS
15	1	00023100	BOLT
16	8	4689	TIE ROD NUT
17	1	4705	PISTON NUT
19	1	00761891	SEAL KIT
20	1	6511324	BREATHER <i>(not illustrated)</i>
		00761802A	CYLINDER ASSEMBLY
1	1	00774728	CLEVIS CAP
2	1	00774735	ROD CAP
3	1	00774733	PISTON
4	1	00774739	ROD
5	1	00774750	TUBE
6	4	00774745	TIE ROD
7*	2	-	'O' RING
8*	1	-	ROD WIPER SEAL
9*	1	-	ROD DUST SEAL
10*	1	-	PISTON SEAL
11*	2	-	PISTON WEAR RING
12*	2	-	BACKUP WASHERS
13	1	3047117	NYLON THREAD PROTECTOR
14	1	1917140	ROD CLEVIS
15	1	00774740	SETSCREW
16	8	33017H5C	TIE ROD NUT
17	1	5JRC16140	PISTON NUT
18	1	1917132	PORT PLUG

* Component part of Seal Kit 00774759

Model: FW6000



WING RAM ASSEMBLY

Module:
22151.02

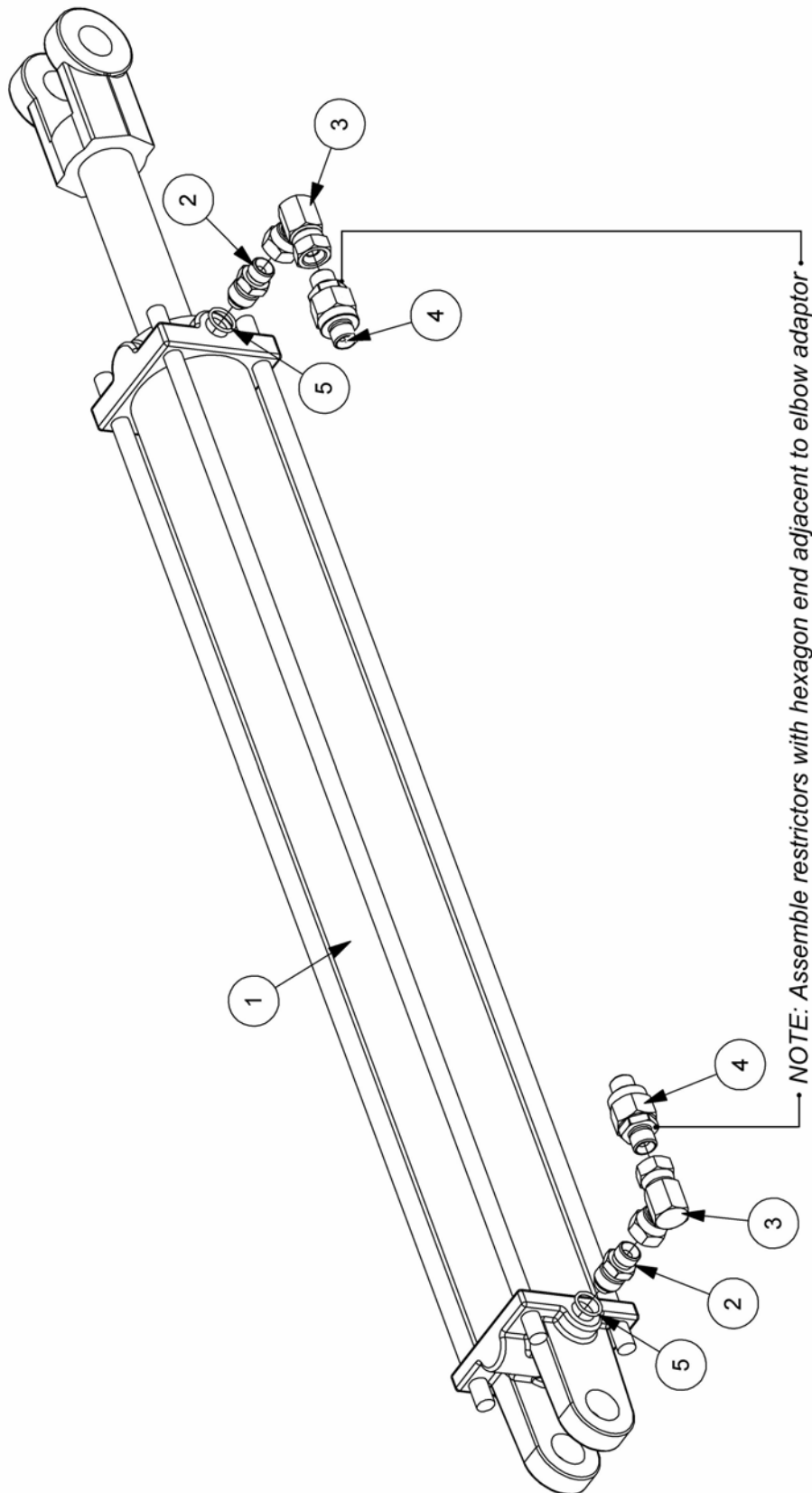

Model: FW6000



WING RAM ASSEMBLY

REF.	QTY.	PART No.	DESCRIPTION
		22151.02	WING RAM ASSEMBLY
1	1	22151.01	RAM
2	2	8581170	ADAPTOR
3	2	8581053	ADAPTOR SWIVEL - 90°
4	2	46518.01	RESTRICTOR
5	2	8600908	O RING

Model: FW6000



HYDRAULIC INSTALLATION

Module:
1058751

Installation for Deck Mount Hoses

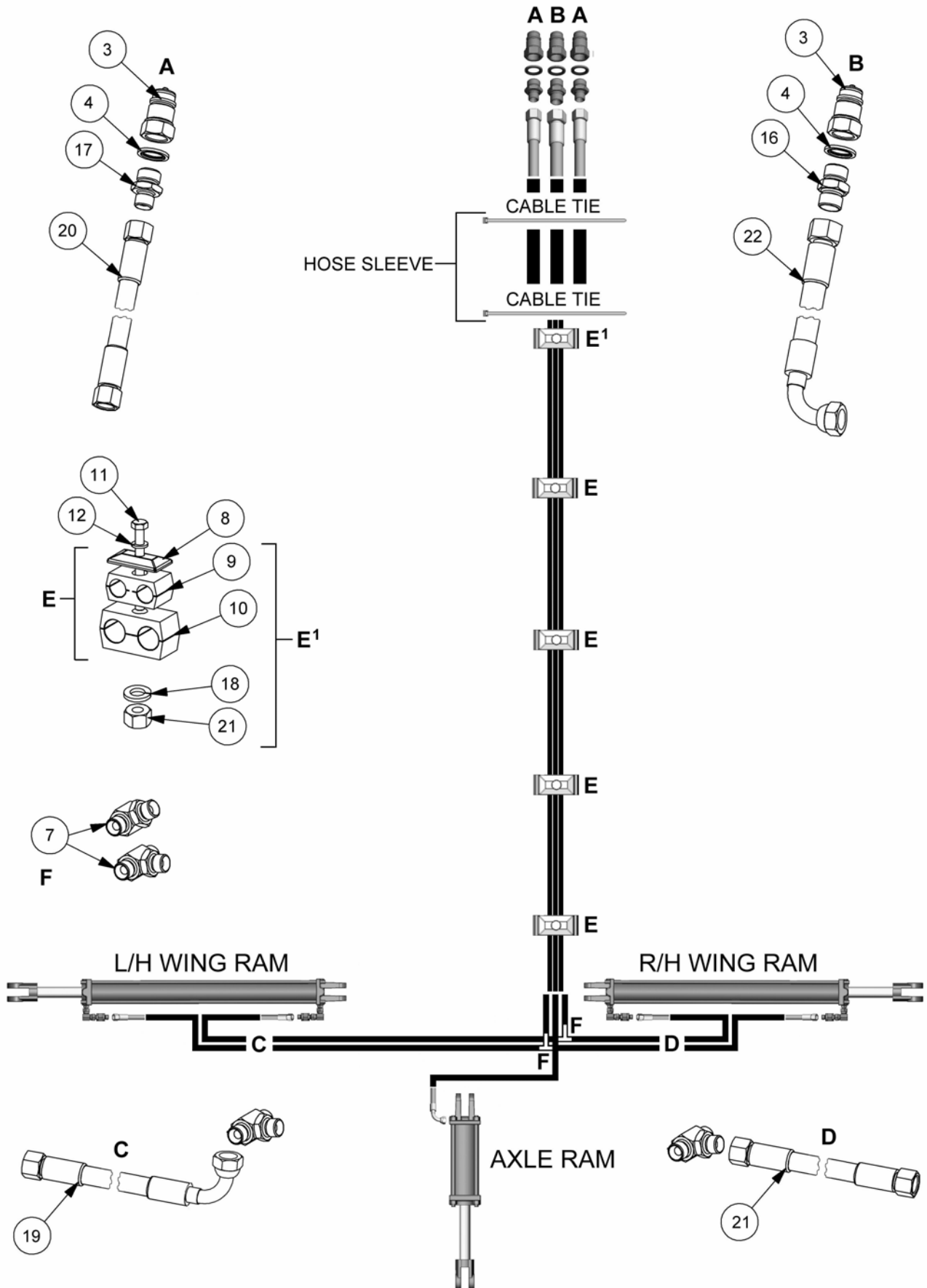

HYDRAULIC INSTALLATION

REF.	QTY.	PART No.	DESCRIPTION
		1058751	HYDRAULIC INSTALLATION (DECK MOUNTED)
1	2	22151.02	WING RAM ASSEMBLY
2	1	00761802	RAM ASSEMBLY
3	3	8590074	QUICK RELEASE COUPLING
4	3	8650104	BONDED SEAL
5	1	08.955.12	ADAPTOR
6	1	8600908	O RING
7	2	8581267	ADAPTOR TEE
8	5	7193066	CLAMP PLATE
9	5	42024.09	TWIN CLAMP
10	5	3020969	PIPE CLAMP
11	4	9213164	BOLT
12	5	9100204	SPRING WASHER
13	1	9213204	BOLT
14	1	9100104	FLAT WASHER
15	1	9143004	SELF-LOCKING NUT
16	1	8581110	ADAPTOR
17	2	6000112	ADAPTOR
18	13	7135084	CABLE TIE
19	2	10.004.29	HOSE - 3/8"BSP FS/F90 x 1900mm
20	2	10.003.62	HOSE - 3/8"BSP FS/FS x 5200mm
21	2	10.003.24	HOSE - 3/8"BSP FS/FS x 1400mm
22	1	10.006.71	HOSE - 1/2" BSP FS/F90 x 6100mm

Note: Secure hoses to the upper tie bars of both L/H & R/H wing rams using cable ties. Wiring loom for lighting runs alongside hoses utilising spare position in hose clamps.

Model: FW6000



HYDRAULIC INSTALLATION

Module:
1058752

Installation for Suspended Hoses

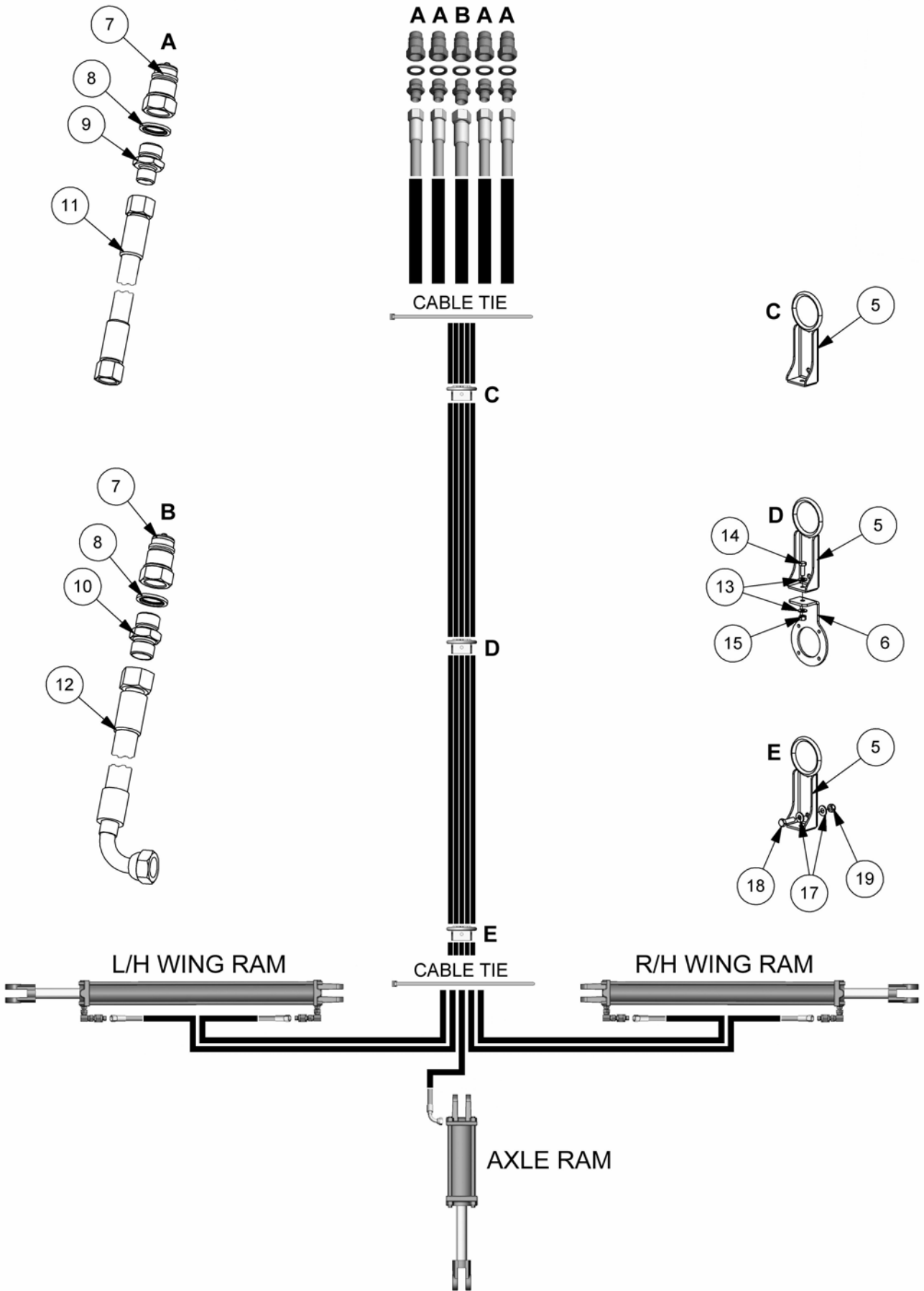

HYDRAULIC INSTALLATION

REF.	QTY.	PART No.	DESCRIPTION
		1058752	HYDRAULIC INSTALLATION (SUSPENDED)
1	2	22151.02	WING RAM ASSEMBLY
2	1	00761802	AXLE RAM ASSEMBLY
3	1	8600908	O RING
4	1	08.955.12	ADAPTOR
5	3	22232.01	HOSE GUIDE
6	1	22235.01	HOSE SUPPORT MOUNTING
7	5	8590074	QUICK RELEASE COUPLING
8	5	8650104	BONDED SEAL
9	4	6000112	ADAPTOR
10	1	8581110	ADAPTOR
11	4	10.003.76	HOSE - 3/8" BSP FS/FS x 6600mm
12	1	10.006.71	HOSE - 1/2" BSP FS/F90 x 6100mm
13	2	9100105	FLAT WASHER
14	1	9213065	BOLT
15	1	9143005	SELF-LOCKING NUT
16	12	7135084	CABLE TIE
17	2	9100106	FLAT WASHER
18	1	9313086	SETSCREW
19	1	9163006	NYLOC NUT

Note: Hose guide 'C' in the diagram opposite is attached to the machine using the longer front bolt and washer that secures the gearbox cover to the divider gearbox.
Secure hoses to the upper tie bars of both L/H & R/H wing rams using cable ties.

Model: FW6000



REAR LIGHTING KIT

Module:
1058758

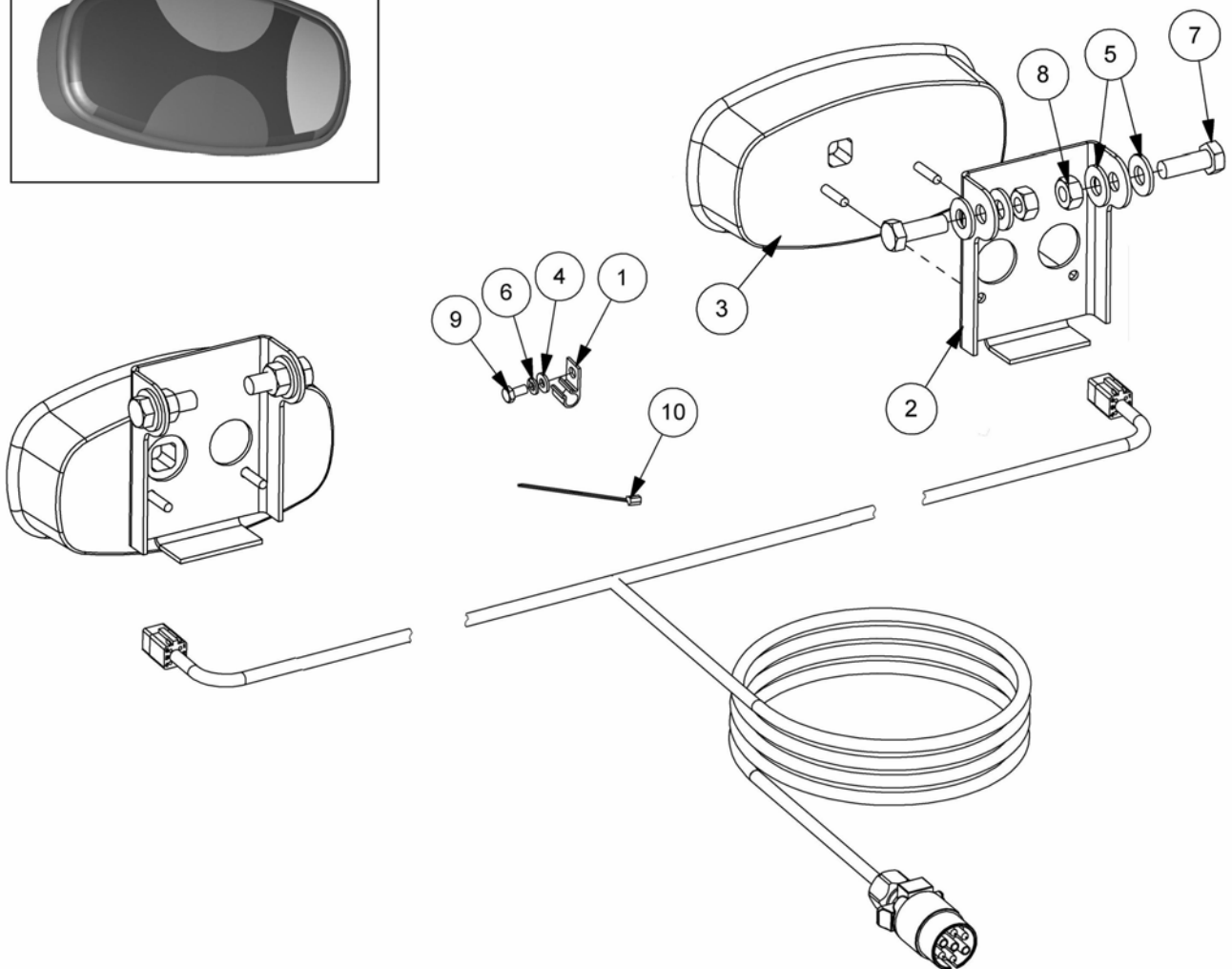
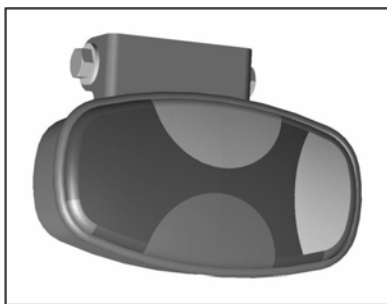
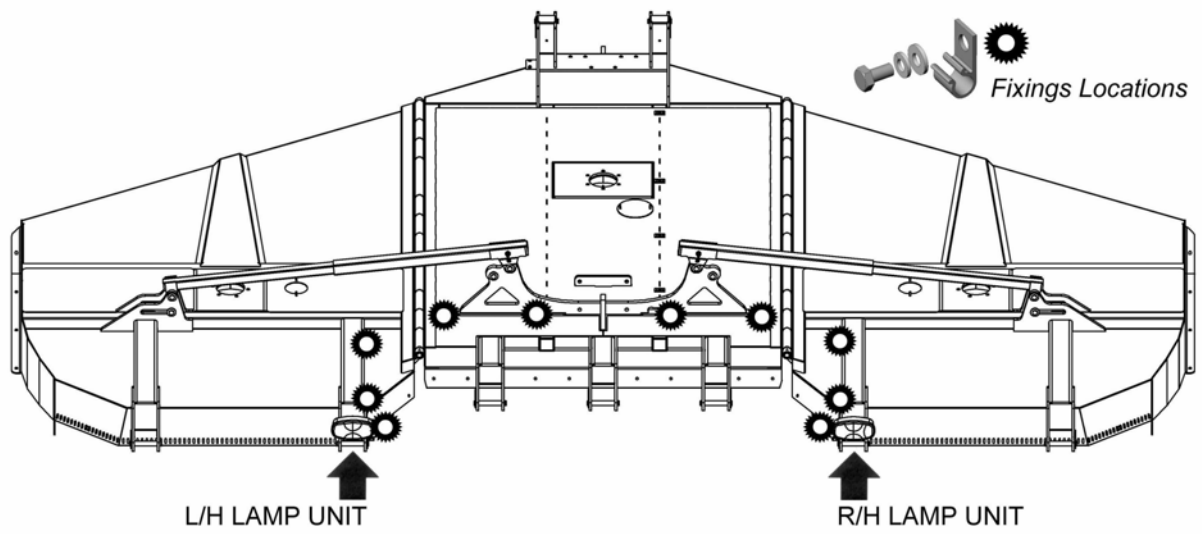



REAR LIGHTING KIT

REF.	QTY.	PART No.	DESCRIPTION
		1058758	LIGHTING KIT
1	10	21151.01	D CLIP
2	2	22244.01	LIGHT MOUNTING BRACKET
3	1	45900.10	LIGHTING KIT - <i>Comprising of:</i>
	1	21392.01	REAR LAMP UNIT - L/H
	1	21392.02	REAR LAMP UNIT - R/H
	1	45656.11	LIGHTING LOOM
4	10	9100103	FLAT WASHER
5	8	9100106	FLAT WASHER
6	10	9100203	SPRING WASHER
7	4	T8095	SELF-LOCKING NUT
8	4	9300139	SETSCREW
9	10	9313023	SETSCREW
10	2	7135084	CABLE TIE

Model: FW6000



DECAL KIT

Module:
1058760

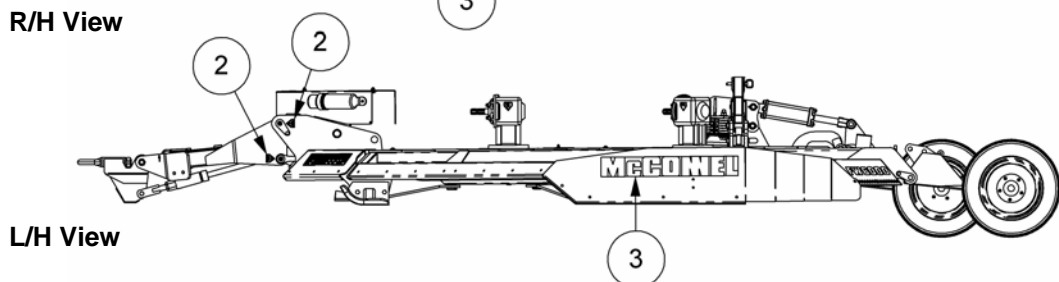
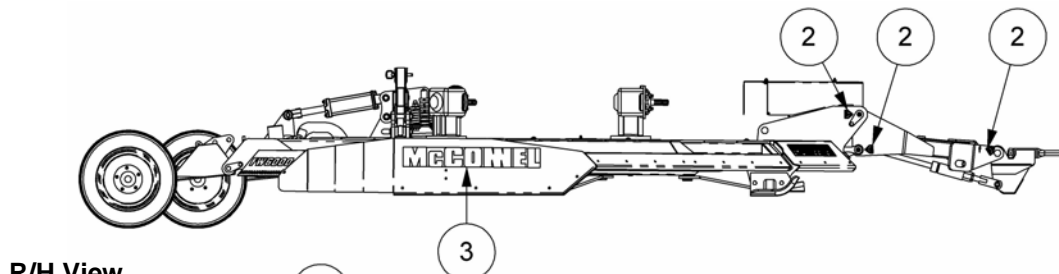
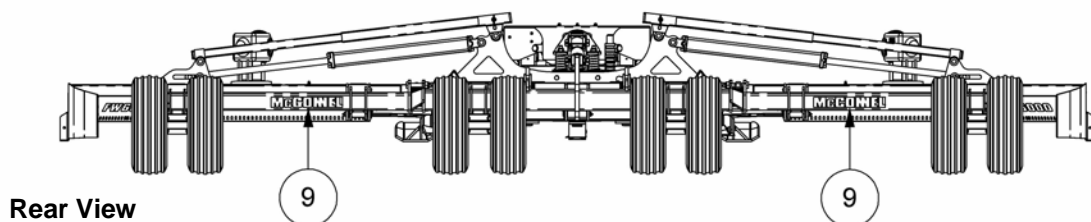
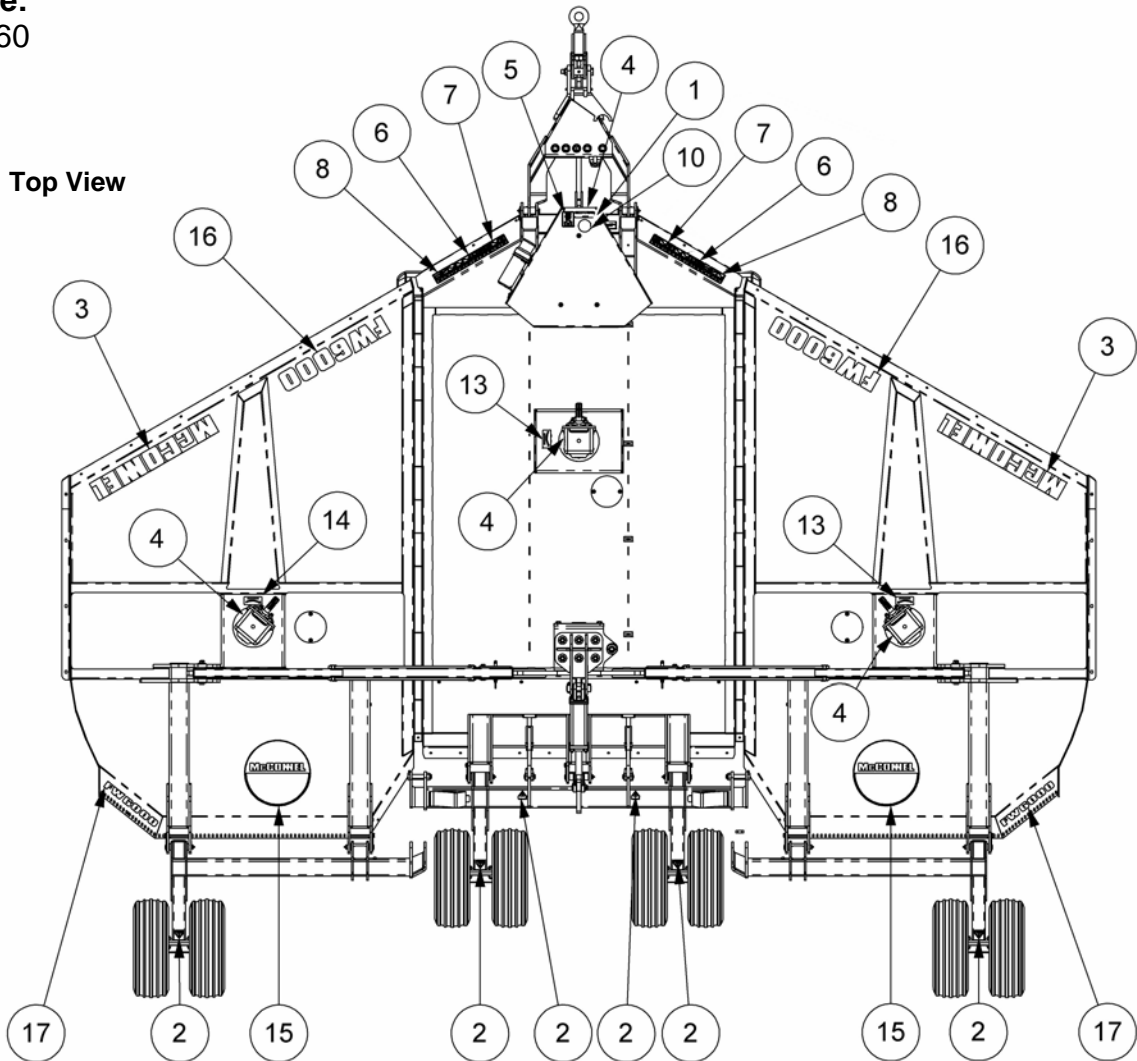

DECAL KIT

REF.	QTY.	PART No.	DESCRIPTION
		1058760	FW6000 DECAL KIT
1	1	00763613	DECAL - SLIP CLUTCH ADJUSTMENT
2	18	09.810.01	DECAL - GREASE (8 HOURS)
3	4	1290527	DECAL - McCONNEL (120mm x 840mm)
4	4	09.810.05	DECAL - OIL LEVEL
5	1	09.811.05	DECAL - 1000RPM MAX (ACW)
6	2	09.821.29	DECAL - COMBINED EURODECAL
7	2	09.821.30	DECAL - EURODECAL ROTARY
8	2	09.821.34	DECAL - COMBINED EURODECAL
9	2	1290614	DECAL - McCONNEL (435mm x 63mm)
10	1	1290571	DECAL - QUEEN'S AWARDS
11	4	7103230	POP RIVET
12	1	1335246	SERIAL No. PLATE
13	2	D137	DECAL - CCW BLADE ROTATION
14	1	D138	DECAL - CW BLADE ROTATION
15	2	1290697	DECAL - McCONNEL ROUNDEL (400mm)
16	2	1290722	DECAL - FW6000 (120mm)
17	2	1290723	DECAL - FW6000 (63mm)



McConnel Limited, Temeside Works, Ludlow, Shropshire SY8 1JL. England.
Telephone: 01584 873131. Facsimile: 01584 876463. www.mcconnel.com