

Publication 560  
December 2008  
Part No. 41571.60

# 1.0M LIGHT DUTY SLIDING FLAILHEAD



Operator & Parts Manual



# EC DECLARATION OF CONFORMITY

*Conforming to EEC Machinery Directive 98/37/EC\**

We,

**McCONNEL LIMITED,**

Temeside Works, Ludlow, Shropshire SY8 1JL.

*Declare under our sole responsibility that:*

The product (type) Hydraulic Arm Mounted Flail Head

Product Code BD12, BD16, F110, F112, F115, F012, F016

Serial No. & Date ..... Type .....

Manufactured by the above company/\* .....

*(\* insert business name and full address if not stated above)*

Complies with the required provisions of the Machinery Directive 98/37/EC, \* previously Directive 89/392/EEC as amended by Directives 91/368/EEC, 93/44/EEC and 93/68/EEC.

The machinery directive is supported by;

- BS EN ISO 12100:2003 Safety of Machinery. This standard is made up of two parts; Part 1 Terminology, methodology, Part 2 Technical Specifications.
- BS EN 1050 Safety of machinery - Principles of risk assessment.
- and other national standards associated with its design and construction as listed in the Technical File.

The Machinery Directive is fully implemented into UK law by means of the Supply of Machinery (Safety) Regulations 1992 (SI 1992/3073) as amended by The Supply of Machinery (Safety) (Amendment) Regulations 1994 (SI 1994/2063).

Signed

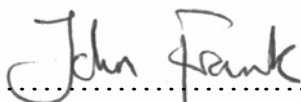

*on behalf of McCONNEL LIMITED*

*Responsible Person*

Status: Chief Design Engineer

Date: December 2008



# CONTENTS

---

	<i>Page No.</i>
<b>Operator Section</b>	
General Information	3
Safety Information	5
Cutting Limitations	9
Roller Positions	9
Flailhead Arrangement for Mowing	10
Flailhead Arrangement for Hedge Cutting	11
Tractor Forward Speed	12
Hedgecutting Procedure	13
Wire Trap	14
Maintenance	14
<b>Parts Section</b>	
Flailhead Assembly	16
Rotor Assembly	18
Roller Assembly	19
Front Flap Kit	20
Skid Kit	21



## GENERAL INFORMATION

---

Always read this manual before fitting or operating the machine – whenever any doubt exists contact your dealer or the McConnel Service Department for advice and assistance.

Use only McConnel Genuine Service Parts on McConnel Equipment and Machines

DEFINITIONS – *The following definitions apply throughout this manual:*

### WARNING

*An operating procedure, technique etc., which – can result in personal injury or loss of life if not observed carefully.*

### CAUTION

*An operating procedure, technique etc., which – can result in damage to either machine or equipment if not observed carefully.*

### NOTE

*An operating procedure, technique etc., which – is considered essential to emphasis.*

### LEFT AND RIGHT HAND

*This term is applicable to the machine when attached to the tractor and is viewed from the rear – this also applies to tractor references.*

## MACHINE & DEALER INFORMATION

***Record the Serial Number of your machine on this page and always quote this number when ordering parts. Whenever information concerning the machine is requested remember also to state the make and model of tractor to which the machine is fitted.***

Machine Serial Number:

Installation Date:

Machine Model details:

Dealer Name:

Dealer Address:

Dealer Telephone No:

Dealer Email Address:





# SAFETY INFORMATION

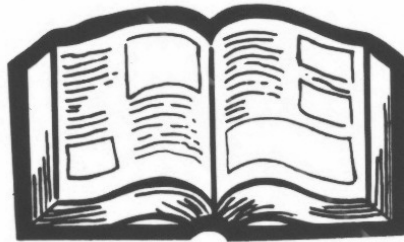

This machine has the potential to be extremely dangerous, in the wrong hands it can kill or maim. It is therefore imperative that both owner, and operator of this machine, read and understand the following section to ensure that they are fully aware of the dangers that do, or may exist, and their responsibilities surrounding the use and operation of the machine. The operator of this machine is responsible not only for their own safety but equally for the safety of others who may come into the close proximity of the machine, as the owner you are responsible for both.

When the machine is not in use the cutting head should be lowered to rest on the ground. In the event of a fault being detected with the machine's operation it should be stopped immediately and not used again until the fault has been corrected by a qualified technician.

## POTENTIAL SIGNIFICANT DANGERS ASSOCIATED WITH THE USE OF THIS MACHINE:

- ▲ *Being hit by debris thrown by rotating components.*
- ▲ *Being hit by machine parts ejected through damage during use.*
- ▲ *Being caught on a rotating power take-off (PTO) shaft.*
- ▲ *Being caught in other moving parts i.e.: belts, pulleys and cutting heads.*
- ▲ *Electrocution from Overhead Power Lines (by contact with or 'flashover' from).*
- ▲ *Being hit by cutting heads or machine arms as they move.*
- ▲ *Becoming trapped between tractor and machine when hitching or unhitching.*
- ▲ *Tractor overbalancing when machine arm is extended.*
- ▲ *Injection of high-pressure oil from hydraulic hoses or couplings.*
- ▲ *Machine overbalancing when freestanding (out of use).*
- ▲ *Road traffic accidents due to collision or debris on the road.*



## BEFORE USING THIS MACHINE YOU MUST:

- ▲ *Ensure you read all sections of the operator handbook.*
- ▲ *Ensure the operator is, or has been, properly trained to use the machine.*
- ▲ *Ensure the operator has been issued with and reads the operator handbook.*
- ▲ *Ensure the operator understands and follows the instructions in operator handbook.*
- ▲ *Ensure the tractor front, rear and side(s) are fitted with metal mesh or polycarbonate guards of suitable size and strength to protect the operator against thrown debris or parts.*
- ▲ *Ensure tractor guards are fitted correctly, are undamaged and kept properly maintained.*
- ▲ *Ensure that all machine guards are in position, are undamaged, and are kept maintained in accordance with the manufacturer's recommendations.*
- ▲ *Ensure flails and their fixings are of a type recommended by the manufacturer, are securely attached and that none are missing or damaged.*
- ▲ *Ensure hydraulic pipes are carefully and correctly routed to avoid damage by chaffing, stretching or pinching and that they are held in place with the correct fittings.*
- ▲ *Always follow the manufacturer's instructions for attachment and removal of the machine from the tractor.*
- ▲ *Check that the machine fittings and couplings are in good condition.*
- ▲ *Ensure the tractor meets the minimum weight recommendations of the machine's manufacturer and that ballast is used as necessary.*
- ▲ *Always inspect the work area thoroughly before starting to note obstacles and remove wire, bottles, cans and other debris.*
- ▲ *Use clear suitably sized warning signs to alert others to the nature of the machine working within that area. Signs should be placed at both ends of the work site. (It is recommended that signs used are of a size and type specified by the Department of Transport and positioned in accordance with their, and the Local Highways Authority, guidelines).*
- ▲ *Ensure the operator is protected from noise. Ear defenders should be worn and tractor cab doors and windows must be kept closed. Machine controls should be routed through proprietary openings in the cab to enable all windows to be shut fully.*
- ▲ *Always work at a safe speed taking account of the conditions i.e.: terrain, highway proximity and obstacles around and above the machine. Extra special attention should be applied to Overhead Power Lines. Some of our machines are capable of reach in excess of 8 metres (26 feet) this means they have the potential to well exceed, by possibly 3 metres (9' 9"), the lowest legal minimum height of 5.2 metres from the ground for 11,000 and 33,000 volt power lines. It cannot be stressed enough the dangers that surround this capability, it is therefore vital that the operator is fully aware of the maximum height and reach of the machine, and that they are fully conversant with all aspects regarding the safe minimum distances that apply when working with machines in close proximity to Power Lines. (Further information on this subject can be obtained from the Health & Safety Executive or your Local Power Company).*

- ▲ *Always disengage the machine, kill the tractor engine, remove and pocket the key before dismounting for any reason.*
- ▲ *Always clear up all debris left at the work area, it may cause hazard to others.*
- ▲ *Always ensure when you remove your machine from the tractor that it is left in a safe and stable position using the stands and props provided and secured if necessary.*

#### WHEN NOT TO USE THIS MACHINE:

- ▲ *Never attempt to use this machine if you have not been trained to do so.*
- ▲ *Never use a machine until you have read and understood the operator handbook, are familiar with it, and practiced the controls.*
- ▲ *Never use a machine that is poorly maintained.*
- ▲ *Never use a machine if guards are missing or damaged.*
- ▲ *Never use a machine on which the hydraulic system shows signs of wear or damage.*
- ▲ *Never fit, or use, a machine on a tractor that does not meet the manufacturer's minimum specification level.*
- ▲ *Never use a machine fitted to a tractor that does not have suitable front, rear and side(s) cab guarding made of metal mesh or polycarbonate.*
- ▲ *Never use the machine if the tractor cab guarding is damaged, deteriorating or badly fitted.*
- ▲ *Never turn a machine cutting head to an angle that causes debris to be ejected towards the cab.*
- ▲ *Never start or continue to work a machine if people are nearby or approaching - Stop and wait until they are at a safe distance before continuing. WARNING: Some Cutting Heads may continue to 'freewheel' for up to 40 seconds after being stopped.*
- ▲ *Never attempt to use a machine on materials in excess of its capability.*
- ▲ *Never use a machine to perform a task it has not been designed to do.*
- ▲ *Never operate the tractor or machine controls from any position other than from the driving seat, especially whilst hitching or unhitching the machine.*
- ▲ *Never carry out maintenance of a machine or a tractor whilst the engine is running – the engine should be switched off, the key removed and pocketed.*
- ▲ *Never leave a machine unattended in a raised position – it should be lowered to the ground in a safe position on a level firm site.*
- ▲ *Never leave a tractor with the key in or the engine running.*
- ▲ *Never carry out maintenance on any part or component of a machine that is raised unless that part or component has been properly substantially braced or supported.*
- ▲ *Never attempt to detect a hydraulic leak with your hand – use a piece of cardboard.*
- ▲ *Never allow children near to, or play on, a tractor or machine under any circumstances.*

## ADDITIONAL SAFETY ADVICE

### Training

Operators need to be competent and fully capable of operating this machine in a safe and efficient way prior to attempting to use it in any public place. We advise therefore that the prospective operator make use of relevant training courses available such as those run by the Agricultural Training Board, Agricultural Colleges, Dealers and McConnel.

### Working in Public Places

When working in public places such as roadsides, consideration should be paid to others in the vicinity. Stop the machine immediately when pedestrians, cyclists and horse riders etc. pass. Restart only when they are at a distance that causes no risk to their safety.

### Warning Signs

It is advisable that any working area be covered by suitable warning signs and statutory in public places. Signs should be highly visible and well placed in order to give clear advanced warning of the hazard. Contact the Department of Transport or your Local Highways Authority to obtain detailed information on this subject. The latter should be contacted prior to working on the public highway advising them of the time and location of the intended work asking what is required by way of signs and procedure. – ‘*Non-authorised placement of road signs may create offences under the Highways Act*’.

### Suggested Warning Signs Required

**“Road works ahead”** warning sign with a supplementary **“Hedge cutting”** plate. **“For 1 mile”** or appropriate shorter distance may be added to the plate.

**“Road narrows”** warning sign with supplementary **“Single file traffic”** plate.

White on blue **“Keep right”** (\*) arrow sign on rear of machine.

\* Note – this applies to UK Market machines where traffic passes to the right of a machine working in the same direction as the traffic flow. The direction, use and colour of the arrow sign will depend on the country of use and the Local Highway Authorities regulations in the locality.

### Use of Warning Signs

- ▲ On two-way roads one set of signs is needed facing traffic in each direction.
- ▲ Work should be within 1 mile of the signs.
- ▲ Work only when visibility is good and at times of low risk e.g.: NOT during ‘rush-hour’.
- ▲ Vehicles should have an amber-flashing beacon.
- ▲ Ideally, vehicles should be conspicuously coloured.
- ▲ Debris should be removed from the road and path as soon as practicable, and at regular intervals, wearing high visibility clothing and before removing the hazard warning signs.
- ▲ Collect all road signs promptly when the job is completed.

---

Although the information given here covers a wide range of safety subjects, it is impossible to predict every eventuality that can occur under differing circumstances whilst operating this machine. No advice given here can replace ‘good common sense’ and ‘total awareness’ at all times, but will go a long way towards the safe use of your McConnel machine.

---

# OPERATION

## Material Thickness Cutting Limitations



## Roller Positions

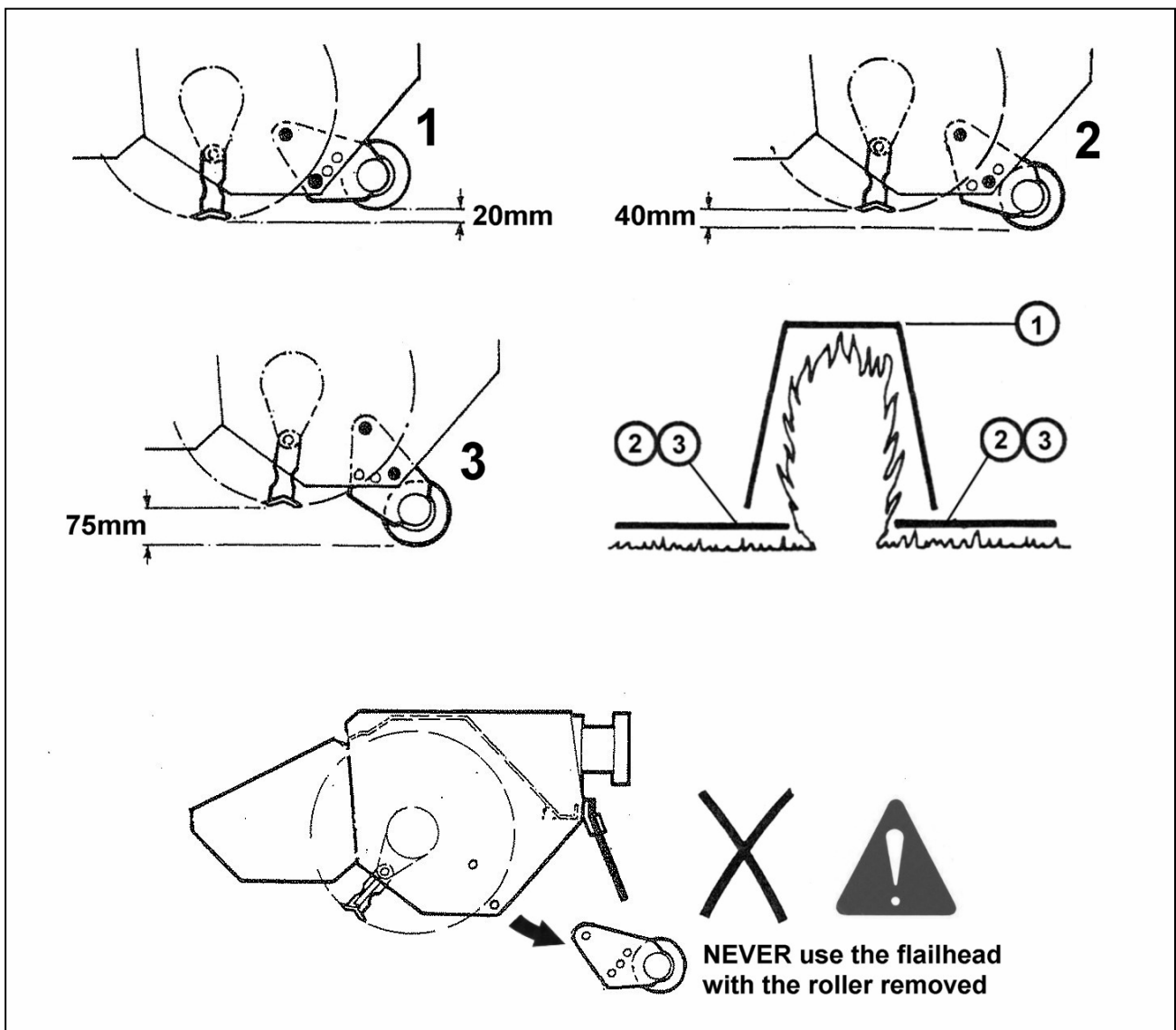

## Preliminary Precautions

Inspect the work area prior to operation, remove all hazardous materials and note the locations of immovable obstructions.

## FLAILHEAD ARRANGEMENT

---

### MOWING

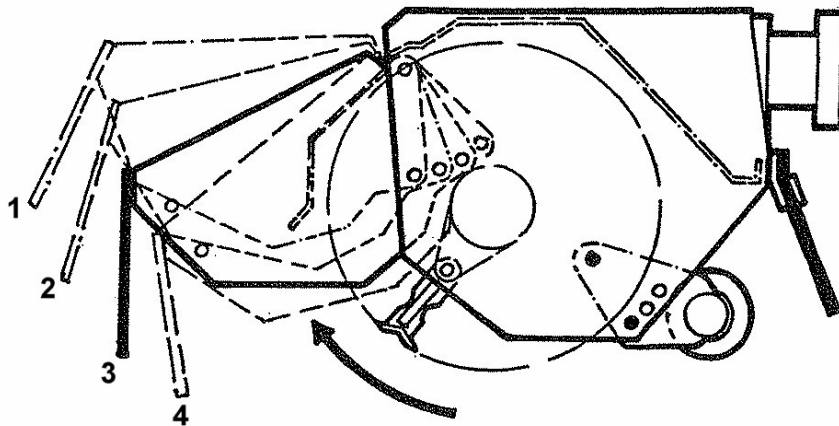

For mowing work the rotor must always cut with an upwards rotation and the roller set to a working height that is below the level of the skids (or rotor if skids are not fitted) – i.e. in position 2 or position 3 as shown on the previous page.

The front hood has four height adjustment positions – the lowest possible position which allows the material to be cut to enter the head should always be used.

**WARNING:** Raising the front hood increases the possibility of debris escaping – never operate the machine with the front hood set any higher than is absolutely necessary.

## HEDGE CUTTING – Upward Cutting

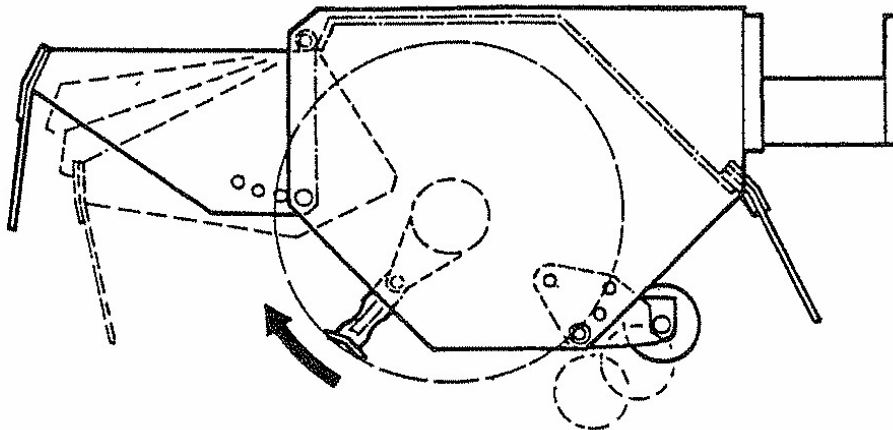

For normal trimming work on hedges the rotor should be set to cut with an upwards rotation – this produces a better finish to the work and demands lower power requirement. Front hood and rear flap must always be in position.

The roller should be set slightly higher than the rotor – i.e. in position 1 as shown on the previous roller position page.

The front hood has four height adjustment positions – the lowest possible position which allows the material to be cut to enter the head should always be used. Front flaps if fitted may be removed to aid entry of the material to be cut into the flail head.

**WARNING:** Raising the front hood increases the possibility of debris escaping – never operate the machine with the front hood set any higher than is absolutely necessary.

## HEDGE CUTTING – Downward Cutting

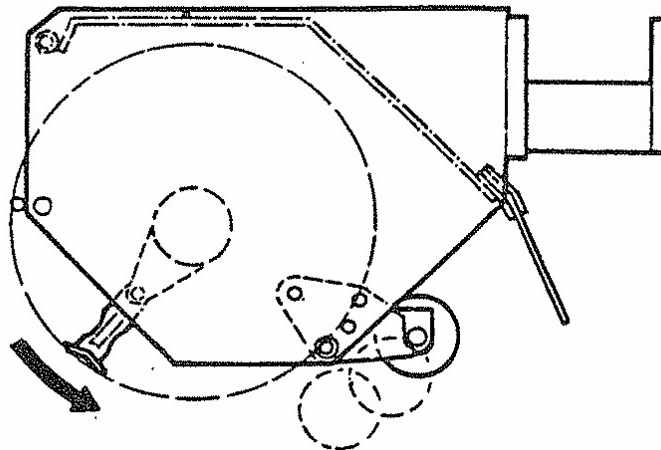

Where the size of the material to be cut makes it necessary for the front hood and carrier plates to be removed to allow the rotor to cut, the rotor must always be set to cut with downwards rotation – this results in a poorer finish to the work and demands higher power requirement.

The roller should be set slightly higher than the rotor – i.e. in position 1 as shown on the previous roller position page.

The rear flap must always remain in position to deflect the cut material downwards into the hedge. Because of the tendency to eject material out of the rear of the hood when downward cutting it is important that the rear flap is kept in good condition and replaced if excessive worn or damaged.

**WARNING:** Do not remove guarding under any circumstances during operation.

## TRACTOR FORWARD SPEED

---

The material being cut determines tractor forward speed. Forward speed can be as fast as that which allows the flail head sufficient time to cut the vegetation properly. Too fast a speed will be indicated by over frequent operation of the breakaway system, a fall off in tractor engine revs and a poor finish to the work leaving ragged uncut tufts and poorly mulched cuttings.

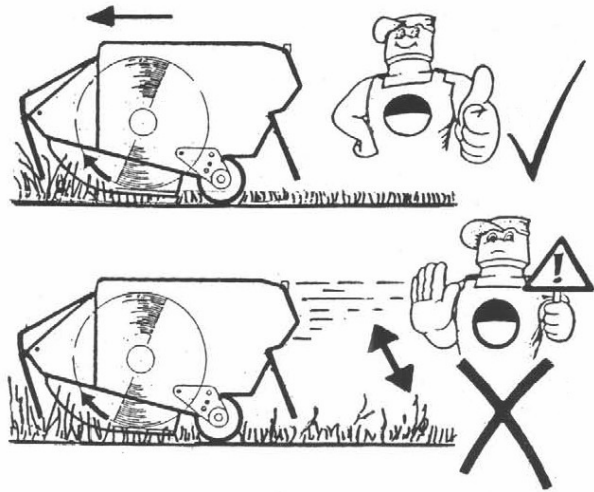

# HEDGECUTTING PROCEDURE



## WARNING!

**Never cut on the blind side of the hedge**

It is impossible to see potential hazards or dangers and the position of the flail head may allow debris to be propelled through the hedge towards the tractor and the operator.

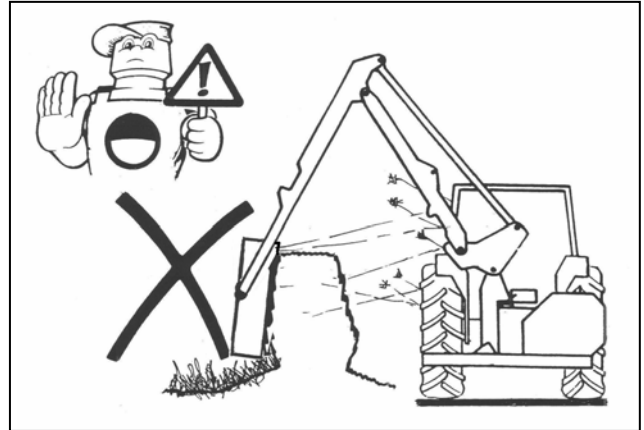

Cut the side and bottom of the field side first. This leaves the maximum thickness of hedge on the road side to prevent the possibility of debris being thrown through the hedge into the path of oncoming vehicles.

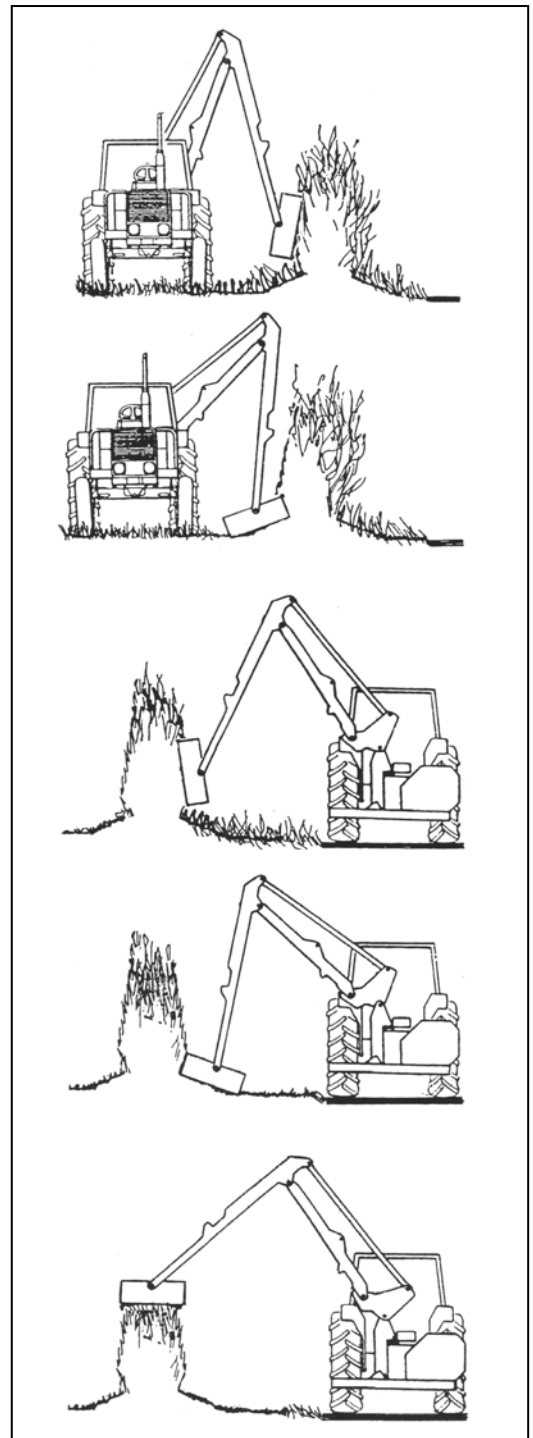

Cut the side and bottom of the road side.

Top cut the hedge to the height required.



## WIRE TRAP

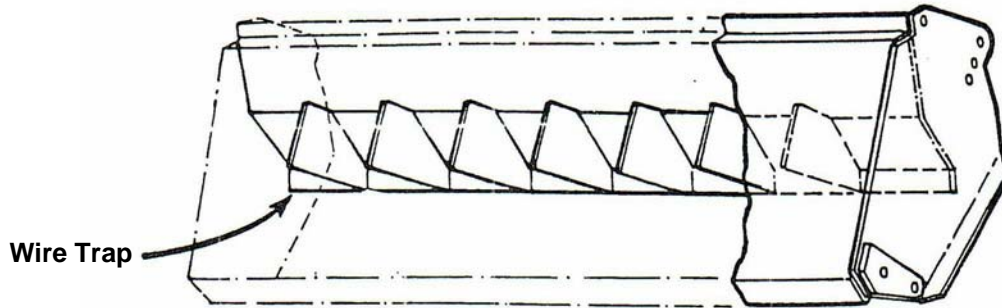

The flailhead is equipped with a 'wire cutting' edge welded into the underside – this plate should not be interfered with in any way. If wire becomes caught in the rotor the machine must be switched off immediately and the wire removed.

### Removing Wire

Select 'Rotor Off' and wait until the rotor has stopped turning completely.

Switch off the tractor and remove the starting key before attempting to remove the wire.

**WARNING:** Do not reverse the rotor in an attempt to unwind the wire.

## MAINTENANCE

---

Frequently inspect the rotor assembly for damaged or missing flails – Never operate or attempt to run the rotor with flails missing, imbalance will cause severe vibration and can rapidly damage the rotor shaft bearings. As an emergency measure, if a flail is broken off or missing, removal of an opposing flail on the opposite side of the rotor will retain the balance. Replace the flails at the earliest possible opportunity and always replace in opposite pairs. Never match up a new flail with a sharpened or damaged flail as the latter will be lighter thus causing imbalance of the rotor.

Blunt flails absorb more power and leave an untidy finish to the work. They should be sharpened on a grindstone or with a portable grinder periodically. Always wear protective gear when sharpening flails.

### IMPORTANT

On the first day of use with a new flailhead, nuts should be checked for tightness every hour and retightened if required. Thereafter they should be checked on a daily basis prior to use of the machine.

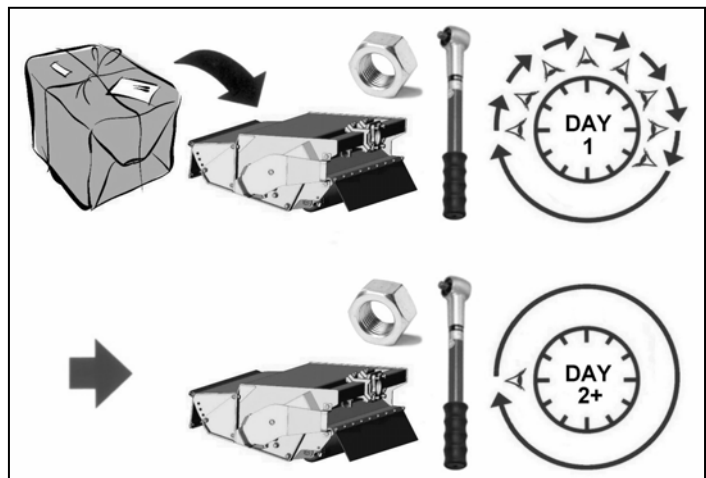

### Lubrication



Grease lubrication points daily.



*For best performance ...*

## **USE ONLY GENUINE McCONNEL SERVICE PARTS**

*To be assured of the latest design improvements purchase your  
'Genuine Replacements' from the 'Original Equipment Manufacturer'*

## **McCONNEL LIMITED**

*Through your local Dealer or Stockist*

**Always quote:**

- ***Machine Type***
- ***Serial Number***
- ***Part Number***

*Design improvements may alter some of the parts listed in this manual –  
the latest part will always be supplied when it is interchangeable with an earlier one.*

# 1.0M SLIDING FLAILHEAD ASSEMBLY

**McCONEL**

Module(s): 7490805

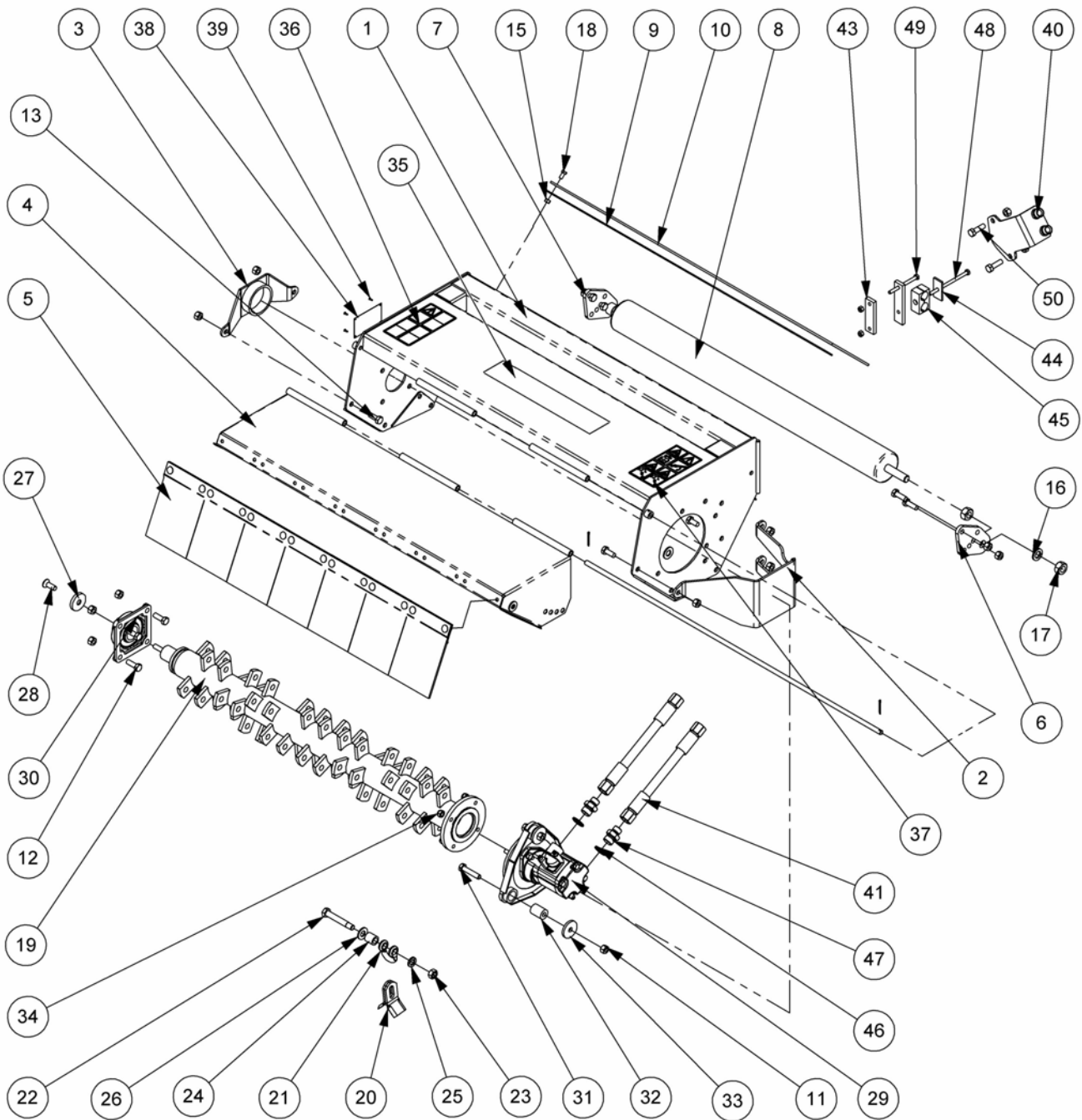

REF.	QTY.	PART No.	DESCRIPTION
		<b>7490805</b>	<b>1.0M SLIDING FLAILHEAD ASSEMBLY</b>
1	1	41282.12	CASING - 1.0m RH IB / LH OB (SLIDING)
	1	41282.11	CASING - 1.0m RH OB / LH IB (SLIDING)
2	1	42495.01	MOTOR COVER - L/H
	1	42495.01	MOTOR COVER - R/H
3	1	42496.01	BEARING COVER
4	1	7442250	FRONT HOOD KIT
5	1	7442254	FRONT FLAP KIT

Continued...

## 1.0M SLIDING FLAILHEAD ASSEMBLY

**McCONNEL**

Module(s): 7490805

REF.	QTY.	PART No.	DESCRIPTION
		<b>7490805</b>	<b>1.0M SLIDING FLAILHEAD ASSEMBLY</b>
6	1	41285.03	ROLLER BRACKET - L/H
7	1	41285.04	ROLLER BRACKET - R/H
8	1	41301.02	ROLLER
9	1	41290.02	CLAMP STRIP
10	1	41289.02	REAR FLAP
11	18	9143006	SELF-LOCKING NUT
12	8	9313076	SETSCREW
13	2	9313066	SETSCREW
14	3	9313056	SETSCREW
15	11	9143004	SELF-LOCKING NUT
16	2	9100208	SPRING WASHER
17	4	9113008	NUT
18	9	9313034	SETSCREW
19	1	41284.02	ROTOR - 1.0M
20	56	7190166	GRASS FLAIL
21	28	05.895.01	SHACKLE
22	28	05.775.10	SPECIAL BOLT
23	28	05.968.06	SELF-LOCKING NUT
24	28	02.807.01	SPACER
25	28	9100207	SPRING WASHER
26	56	05.281.04	FLAT WASHER
27	1	42503.01	SPECIAL WASHER
28	1	9353076	CAPSCREW
29	<del>1</del>	<del>42603.02</del>	MOTOR ASSEMBLY motor 08.785.05
30	1	03.008.01	BEARING FLANGE
31	3	9213126	BOLT
32	3	03.871.01	RUBBER BUSH
33	3	02.824.01	WASHER
34	4	05.968.02	FINE SELF-LOCKING NUT
35	1	305879	DECAL - McCONNEL
36	1	1290738	DECAL - FLAILHEAD
37	1	09.821.35	COMBINED EURO DECAL
38	1	1335246	SERIAL No. PLATE
39	4	7103230	POP RIVET
40	1	41297.01	HOSE BRACKET
41	2	10.007.23	HOSE - 5/8" BSP FS/FS x 1300mm
42	1	21874.01	CLAMP BAR - LONG
43	1	21874.02	CLAMP BAR - SHORT
44	1	06.418.03	CLAMP PLATE
45	1	06.430.09	DOUBLE HOSE CLAMP
46	2	8650106	BONDED SEAL
47	2	8581270	BSP ADAPTOR
48	1	9213284	BOLT
49	1	9213204	BOLT
50	2	9313086	SETSCREW

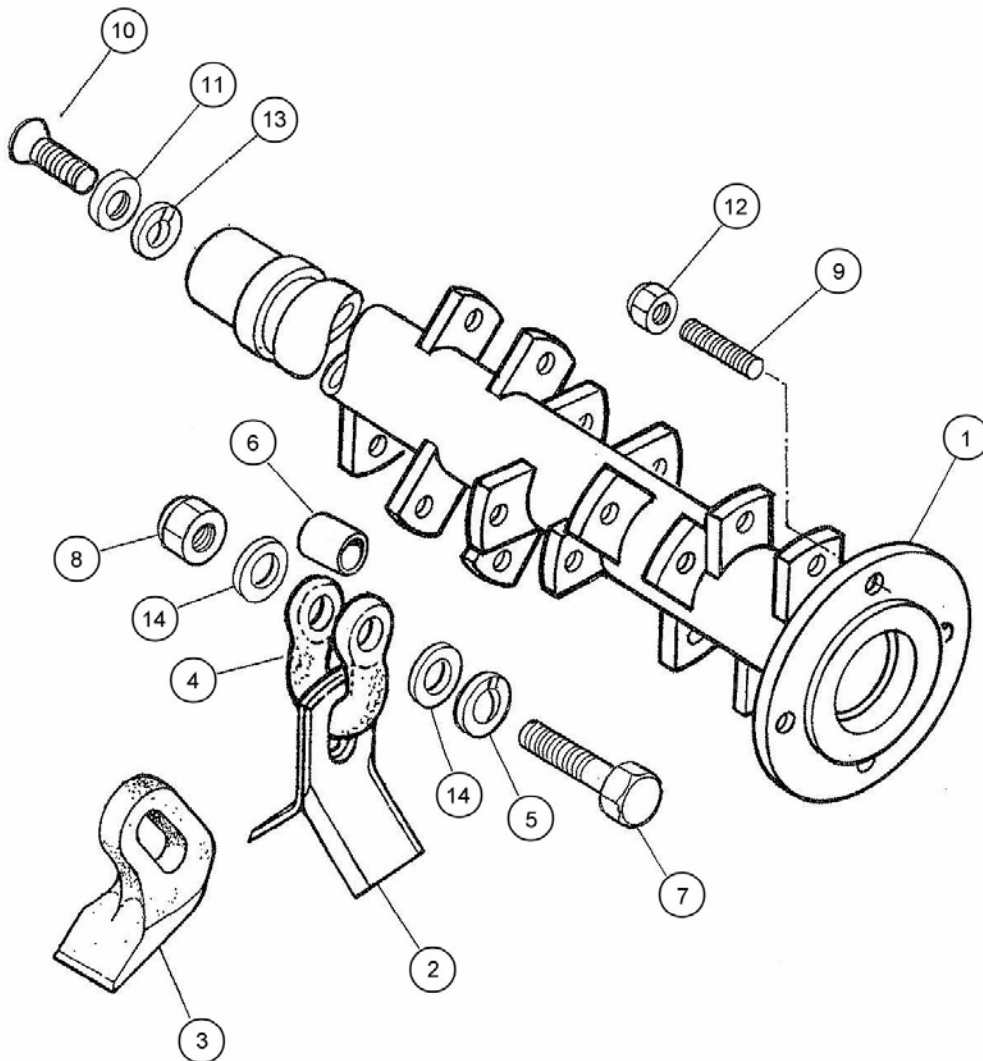

REF.	QTY.	PART No.	DESCRIPTION
			<b>ROTOR ASSEMBLY &amp; FLAIL OPTIONS</b>
1	1	41284.02	ROTOR ASSEMBLY
2	56	7190166	FLAIL - GRASS
3	28	7190463	FLAIL - UNIVERSAL
4	28	05.895.01	SHACKLE
5	28	9100207	SPRING WASHER
6	28	02.807.01	SPACER
7	28	05.775.10	SPECIAL BOLT
8	28	05.968.06	SELF-LOCKING NUT
9	4	03.917.01	STUD
10	1	9353073	SETSCREW
11	1	42503.01	SPECIAL WASHER
12	4	05.968.02	SELF-LOCKING NUT
13	1	9100206	SPRING WASHER
14	56	05.281.04	PLAIN WASHER

# 1.0M ROLLER ASSEMBLY

**McCONNEL**

Module(s): 41301.02

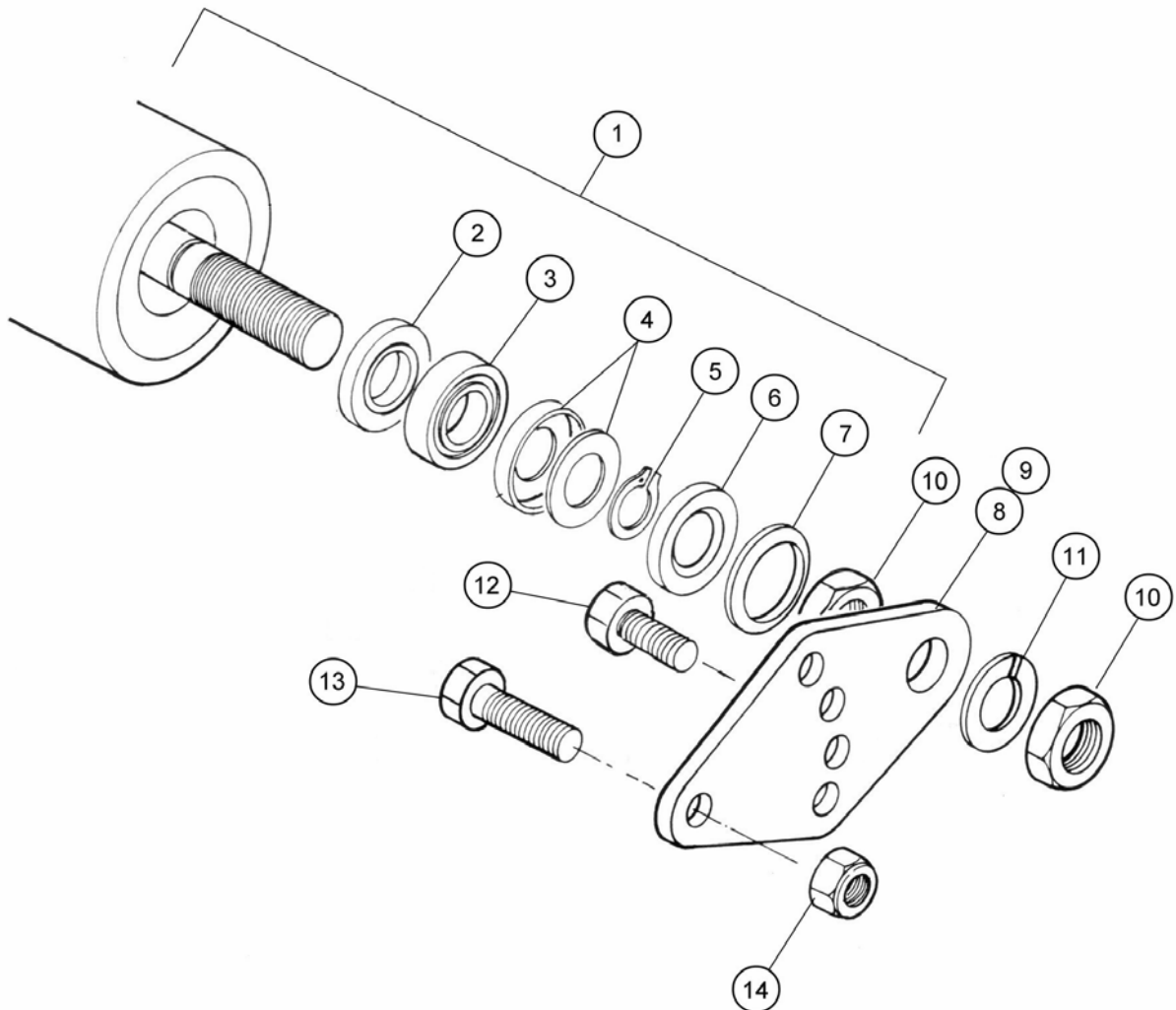

REF.	QTY.	PART No.	DESCRIPTION
			<b>ROLLER ASSEMBLY &amp; FITTINGS</b>
1		41301.02	1.0M ROLLER ASSEMBLY - c/w:
<del>2</del>		<del>04.456.07</del>	<del>SEAL</del>
<del>3</del>		<del>04.456.11</del>	<del>BEARING</del>
<del>4</del>		<del>04.456.06</del>	<del>LABYRINTH SEAL</del>
<del>5</del>		<del>04.456.04</del>	<del>EXTERNAL CIRCLIP</del>
<del>6</del>		<del>04.456.08</del>	<del>V SEAL</del>
<del>7</del>		<del>04.456.05</del>	<del>BEARING RETAINER</del>
8		41285.03	ROLLER BRACKET - L/H
9		41285.04	ROLLER BRACKET - R/H
10		9113008	PLAIN NUT
11		9100208	SPRING WASHER
12		9313066	SETSCREW
13		9313086	SETSCREW
14		9143006	SELF-LOCKING NUT

Vervangen door  
04.456.03  
Ersetz durch  
04.456.03

# FRONT FLAP KIT (Option)

# McCONEL

Module(s): 7490805

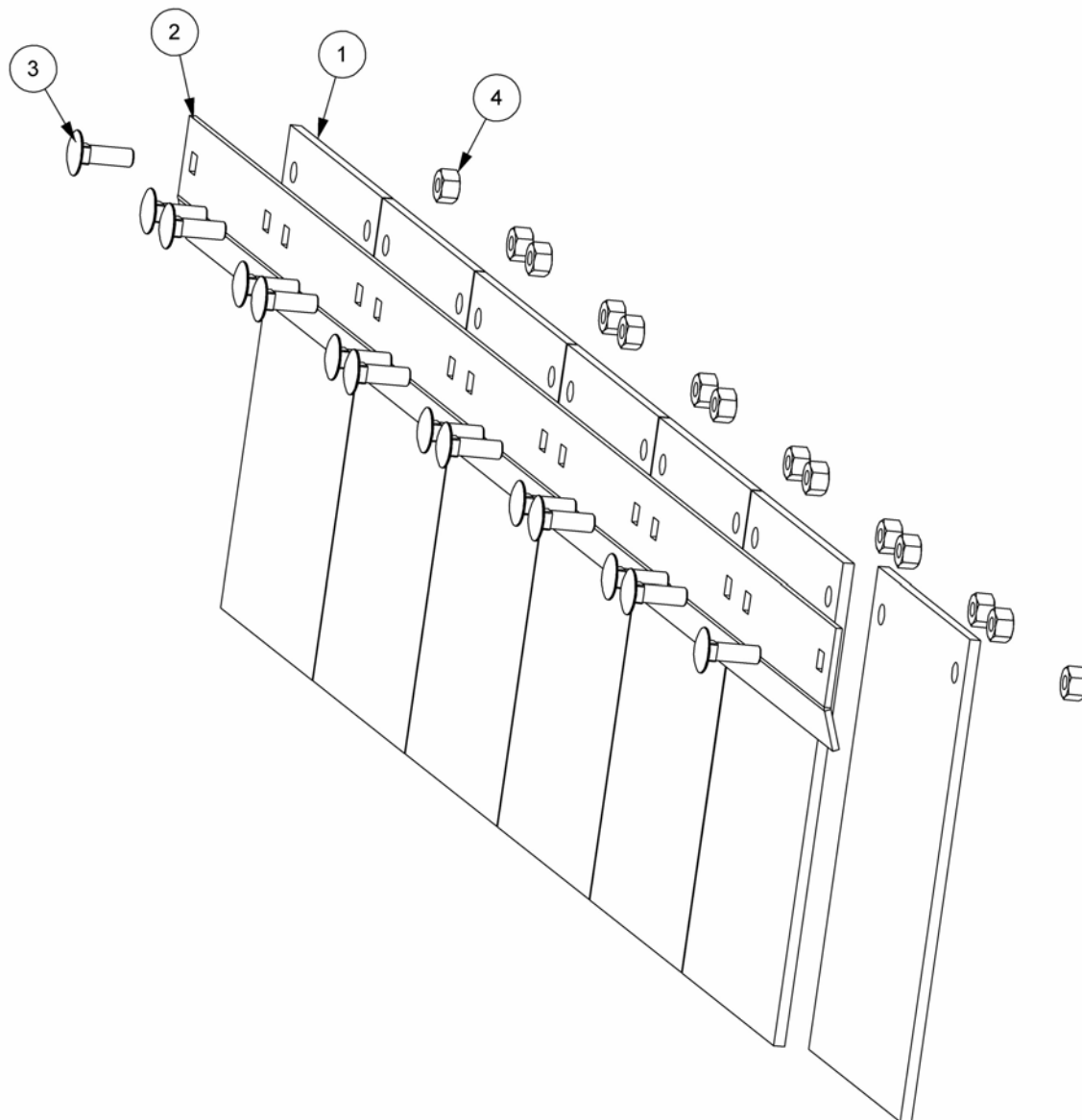

REF.	QTY.	PART No.	DESCRIPTION
		<b>7442254</b>	<b>FRONT FLAP KIT - 1.0M</b>
1	7	41296.02	FRONT FLAP ( 2 HOLES)
2	1	41291.02	FRONT FLAP CLAMP STRIP
3	14	9293054	CUP HEAD SCREW
4	14	9143004	SELF-LOCKING NUT



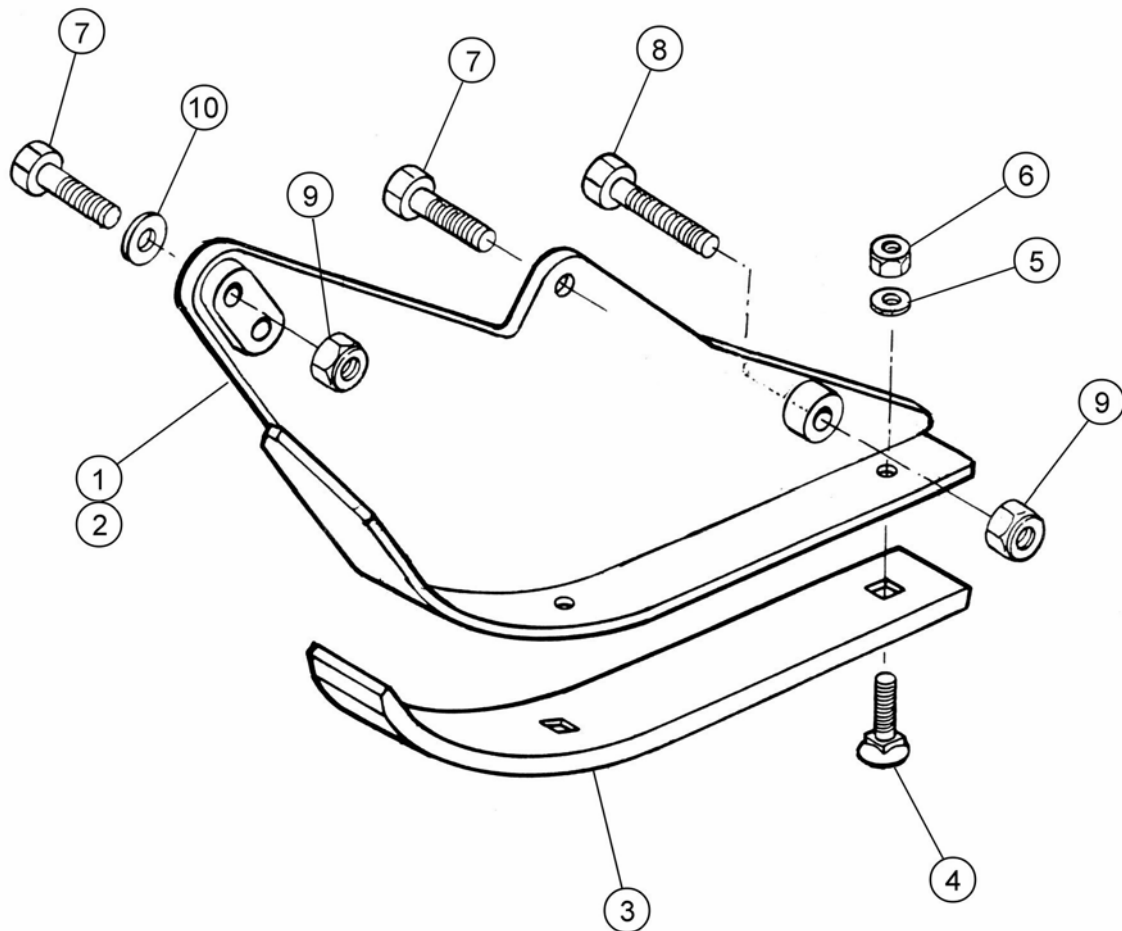

REF.	QTY.	PART No.	DESCRIPTION
		<del>7198374</del>	<del>SKID KIT</del>
1	1	7198368	SKID - L/H
2	1	7198369	SKID - R/H ( <i>not illustrated</i> )
3	2	7290391	WEAR SKID
4	6	<del>6012034</del>	TINE BOLT Ersetz durch 03.675.02
5	6	<del>0100104</del>	PLAIN WASHER
6	6	<del>0142004</del>	SELF-LOCKING NUT
7	4	0311106	SETSCREW
8	2	0311126	SETSCREW
9	4	0141006	SELF-LOCKING NUT
10	6	0100106	PLAIN WASHER





McConnel Limited, Temeside Works, Ludlow, Shropshire SY8 1JL. England.  
Telephone: 01584 873131. Facsimile: 01584 876463. [www.mcconnel.com](http://www.mcconnel.com)