

Publication 410
August 2001
Part No. 41570.11
Revision: 17.01.07



PA 32

HEDGE/GRASS TRIMMER

Parts Manual

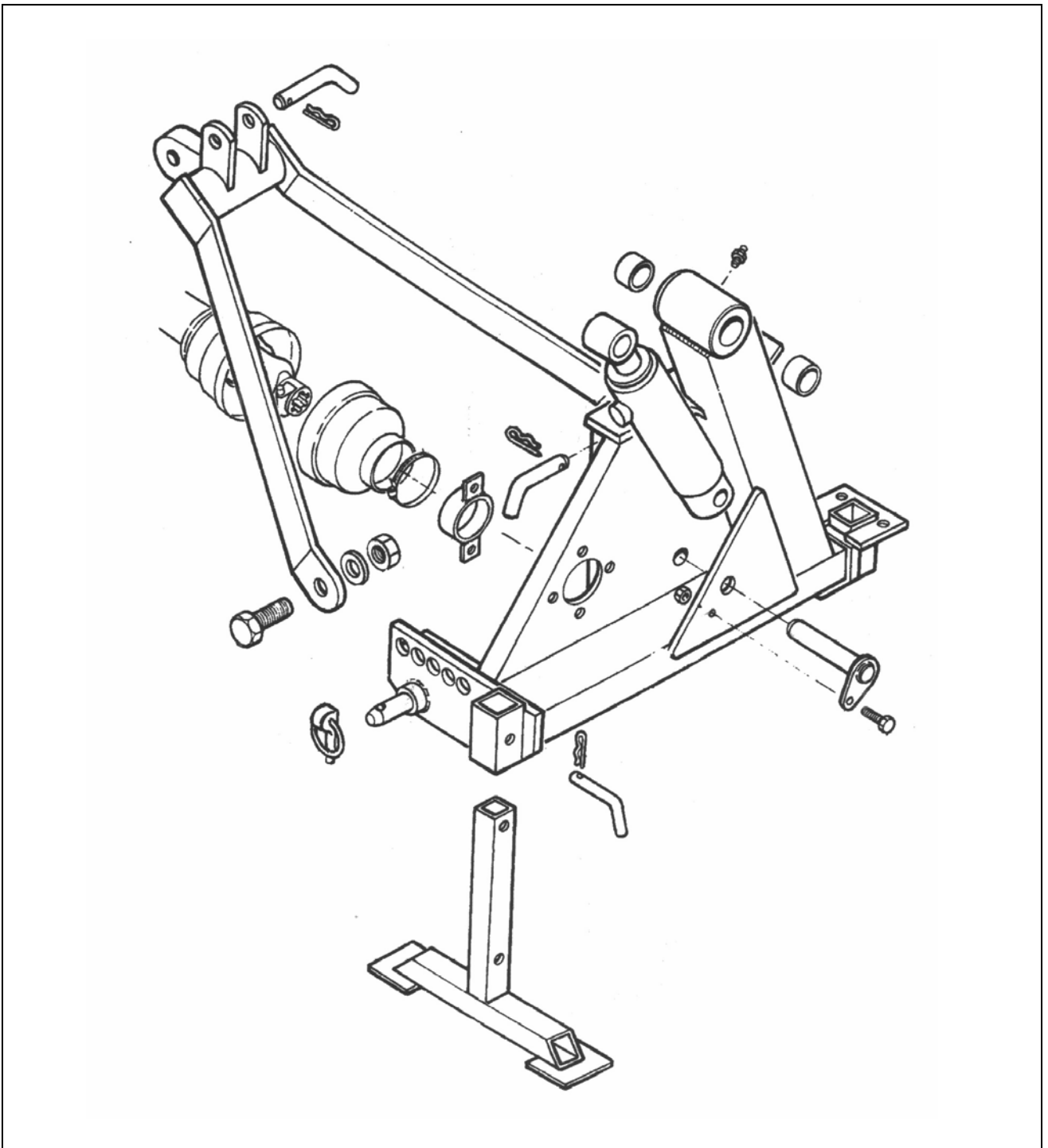



For best performance ...

USE ONLY GENUINE McCONEL SERVICE PARTS

To be assured of the latest design improvements purchase your 'Genuine Replacements' from the 'Original Equipment Manufacturer'

McCONEL LIMITED

Through your local Dealer or Stockist

Always quote:

- **Machine Type**
- **Serial Number**
- **Part Number**

Design improvements may alter some of the parts listed in this manual – the latest part will always be supplied when it is interchangeable with an earlier on.

LIST OF CONTENTS

Component	Page No.
Main Frame	1
Main Arm & Rocker	3
Standard Dipper Arm	5
Control Mounting Assembly	7
Cab Guard Kit	8
Flail Head Casing	9
Rotors, Flails & Roller	11
Cutterbar Drive	13
Cutterbar Assemblies	15
Hose Installation – <i>Si machines</i>	17
Hose Installation – <i>Ti machines</i>	19
Control Valve	21
Control Valve – <i>Ti Electric models</i>	23
Rotor Control valve – <i>Ti models only</i>	25
Proportional Control Valve & Electric Rotor Reverse Valve	27
Rotor Switchbox & Valve Assembly	29
Control Unit & Cables – <i>Cable models</i>	31
Monolever Controls – <i>Electric models</i>	33
Control Box – <i>Proportional Models</i>	35
Pump & Gearbox Assembly – <i>Si models</i>	37
Pump & Gearbox Assembly – <i>Ti models</i>	39
Gearbox	41
Hydraulic Tank Assembly	42
Lift Float Kit – <i>Optional Extra</i>	43
Lift Ram	44
Reach Ram	45
Breakaway Ram	47
Angling Ram	49
Machine Covers	51
Machine Decals	53

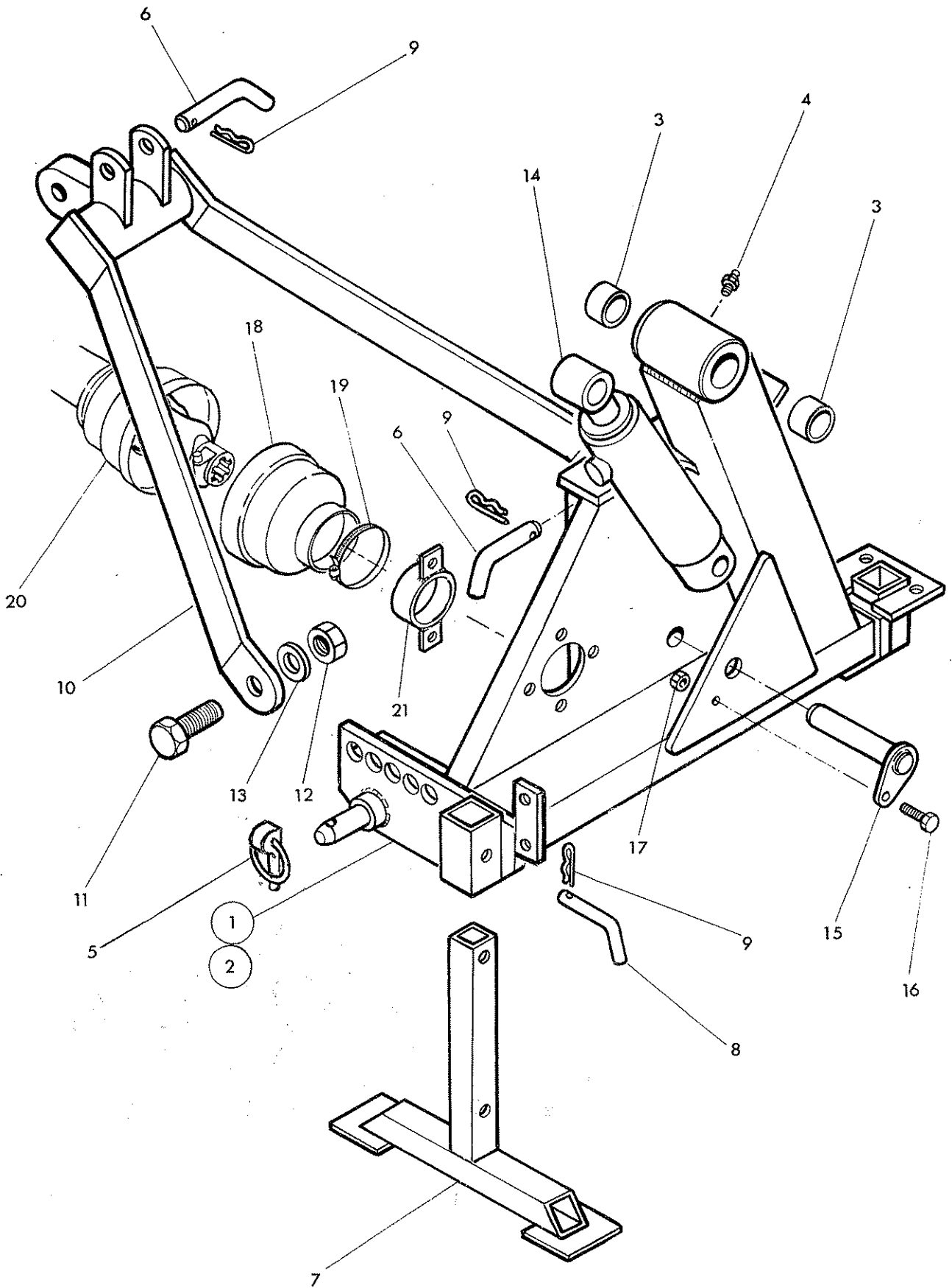
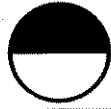



Ref. Part No.	Qty	Description
MAIN FRAME AND STABILISER		
1	41197.01	1 Main frame L.Hand
2	41197.02	1 Main frame R.Hand - not illus.
3	71 01 134	2 Bush
4	09 01 121	1 Greaser
5	04 31 217	1 Linch pin
6	71 92 026	2 Top link pin
7	41203.01	2 Stand leg
8	10 90 051	2 Leg pin
9	04 31 105	4 Spring cotter
10	41205.01	1 Stabiliser
11	91 13 118	2 Setscrew
12	91 13 008	2 Self locking nut
13	91 00 208	2 Spring washer
14	41014.03	1 Lift ram assy.
15	41267.01	1 Pivot pin - lift ram base
16	93 13 065	1 Setscrew
17	91 43 005	1 Self locking nut
18	71.11.038	1 Shaft guard
19	09 04 114	1 Hose clip
20	71 14 289	1 P.T.O. shaft
21	71 91 075	1 Guard mounting collar

MAIN ARM & ROCKER



MCCORMICK

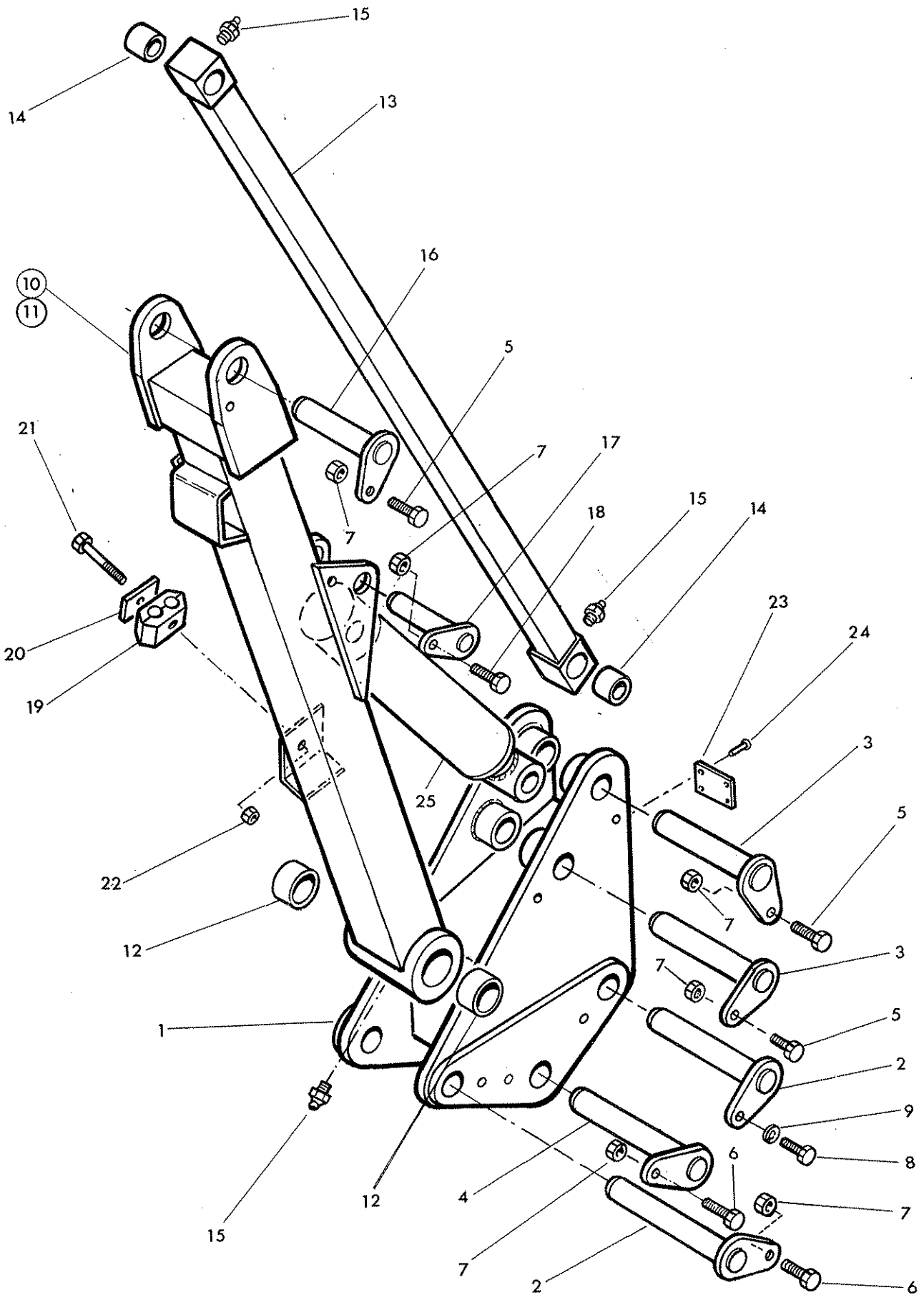



Ref. Part No.	Qty	Description
MAIN ARM AND ROCKER		
1	41198.01	1 Rocker
2	41268.01	1 Pin-rocker and main arm
3	41267.02	1 Pin-link and reach ram rod
4	41267.01	1 Pin - lift ram rod
5	93 13 055	3 Setscrew
6	93 13 065	2 Setscrew
7	91 43 005	6 Self locking nut
8	91 13 045	1 Setscrew
9	91 00 205	1 Spring washer
10	41199.01	1 Main arm L.Hand
11	41199.02	1 Main arm R.Hand - not illus.
12	71 01 134	2 Bush
13	41200.01	1 Tension link
14	71 05 050	2 Bush
15	09 01 121	3 Greaser
16	41268.01	1 Pivot pin - dipper
17	41267.04	1 Pivot pin - reach ram base
18	93 13 075	1 Setscrew
19	06.430.09	2 Hose clamp
20	06.418.03	2 Clamp plate
21	92 13 134	2 Bolt
22	91 43 004	2 Self locking nut
23	13 35 246	1 Serial No. Plate
24	71 03 230	4 Pop rivet
25	41015.03	1 Reach ram assembly

DIPPER ARMS – UPPER & LOWER

Illustrated in Left hand Build

Modules:

- 7490708 – Upper Dipper L/H Build
- 7490709 – Upper Dipper R/H Build
- 7490710 – Lower Dipper L/H Build
- 7490711 – Lower Dipper R/H Build

UPPER DIPPER ASSEMBLY

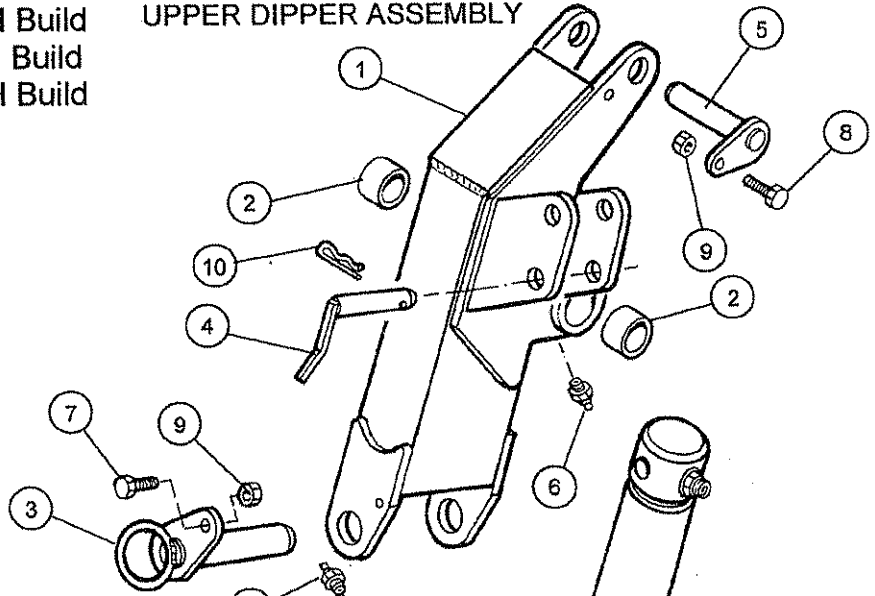

LOWER DIPPER ASSEMBLY

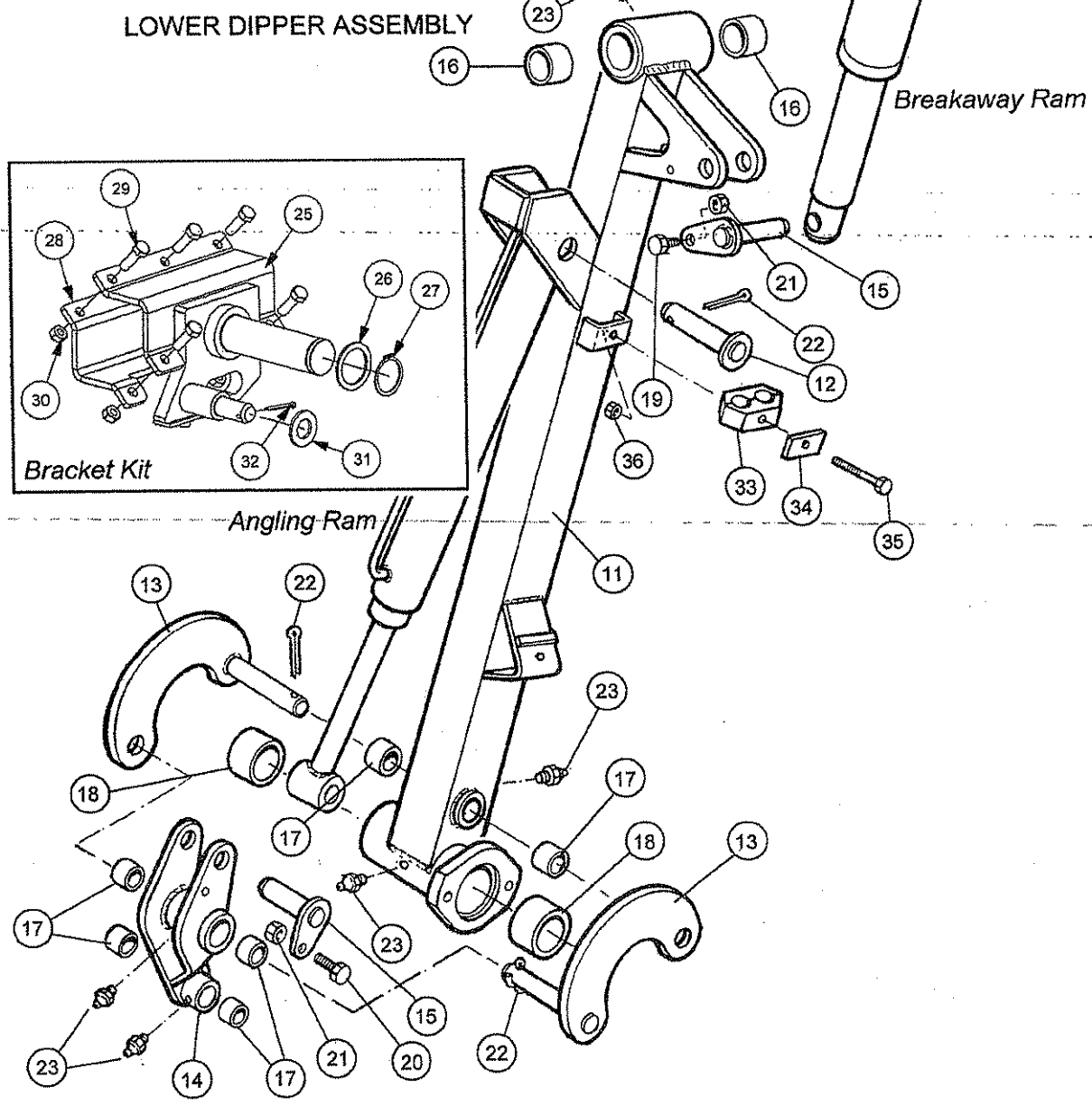

Breakaway Ram

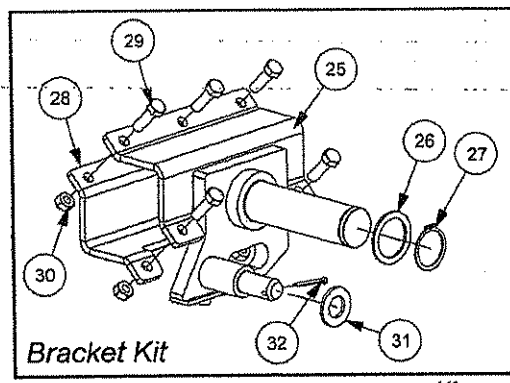

Bracket Kit

Angling Ram



DIPPER ARMS - UPPER & LOWER

REF.	QTY.	PART No.	DESCRIPTION
		7490708	UPPER DIPPER ARM ASSEMBLY - L/H Build
		7490709	UPPER DIPPER ARM ASSEMBLY - R/H Build
1	1	41201.01	UPPER DIPPER ARM - L/H Build
	1	41201.02	UPPER DIPPER ARM - R/H Build (<i>not illustrated</i>)
2	2	21149.01	BUSH
3	1	41269.01	PIN - BREAKAWAY
4	1	7191036	PIN - BREAKAWAY RAM BASE
5	1	41267.03	PIN
6	1	0901121	GREASE NIPPLE
7	1	9313075	SETSCREW
8	1	9313055	SETSCREW
9	2	9143005	SELF-LOCKING NUT
10	1	0431105	SPRING COTTER
		7490710	LOWER DIPPER ARM ASSEMBLY - L/H Build
		7490711	LOWER DIPPER ARM ASSEMBLY - R/H Build
11	1	41202.01	LOWER DIPPER ARM - L/H Build
	1	41202.02	LOWER DIPPER ARM - R/H Build (<i>not illustrated</i>)
12	1	7191041	PIN - ANGLE RAM BASE
13	2	41206.01	RADIUS ARM
14	1	41207.01	SLAVE LINK - L/H Build
	1	41207.02	SLAVE LINK - R/H Build (<i>not illustrated</i>)
15	2	41270.01	PIN - ANGLE RAM ROD
16	2	21149.01	BUSH
17	6	7214060	BUSH
18	2	1090001	BUSH
19	1	9313065	SETSCREW
20	1	9313055	SETSCREW
21	2	9143005	SELF-LOCKING NUT
22	3	9501406	COTTER PIN
23	5	0901121	GREASE NIPPLE
24	1	7490812	BRACKET KIT - L/H Build
	1	7490813	BRACKET KIT - R/H Build
25	1	41261.08	PIVOT BRACKET - L/H Build
	1	41261.04	PIVOT BRACKET - R/H Build
26	1	1090037	RETAINING WASHER
27	1	0406247	EXTERNAL CIRCLIP
28	1	21873.01	CLAMP PLATE
29	5	9313086	SETSCREW
30	5	9143006	SELF-LOCKING NUT
31	1	0100109	FLAT WASHER
32	1	9501406	COTTERPIN
33	2	06.430.09	HOSE CLAMP
34	2	06.418.03	CLAMP PLATE
35	2	9213134	BOLT
36	2	9143004	SELF-LOCKING NUT

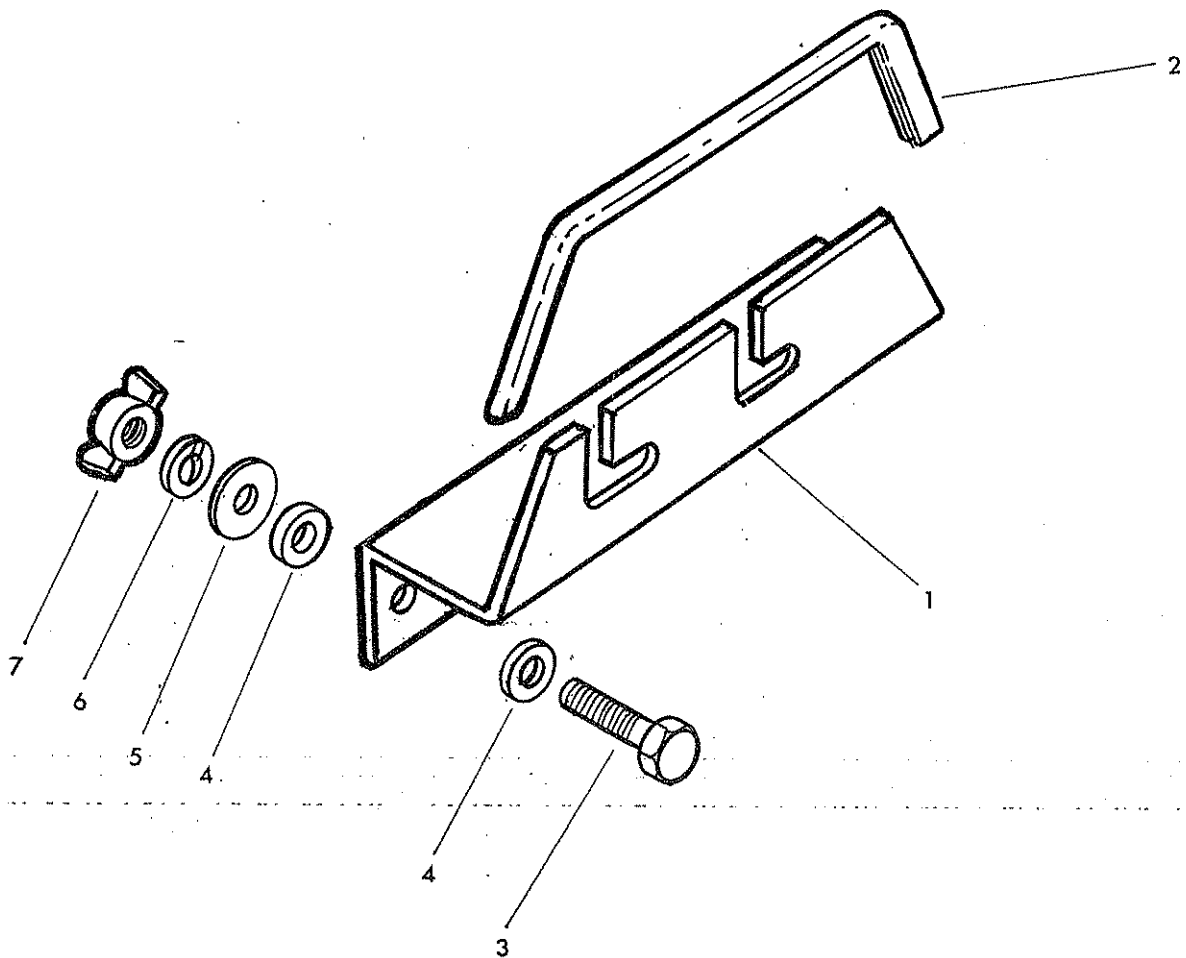
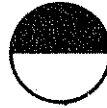
comprises of:

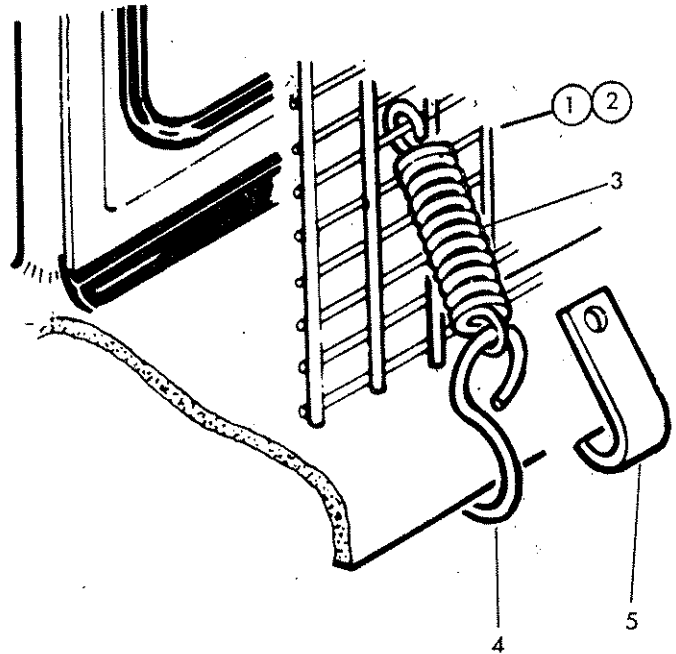
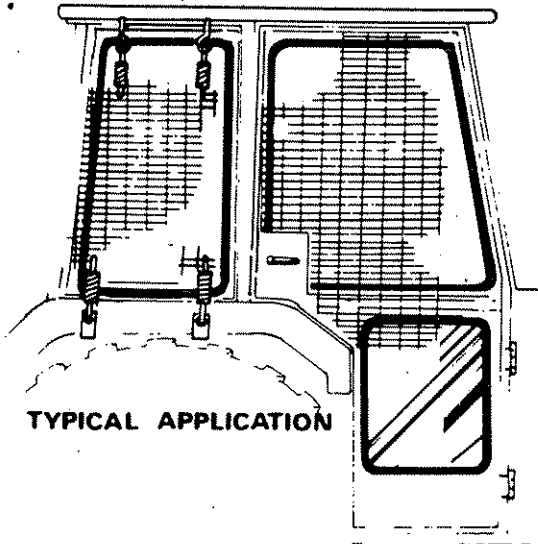

Ref	Part No	Qty	Description
CONTROL UNIT MOUNTING ASSY			
1	03.583.01	1	Bracket
2	03.231.02	1	Rubber edge strip
3	93 13 094	2	Setscrew M8 x 45
4	03.152.01	4	Rubber washer
5	91 00 104	2	Plain washer dia 8
6	91 00 204	2	Spring washer dia 8
7	91 93 004		Wingnut M8



Ref. Part No.	Qty.	Description
73-13-324		CAB GUARD KIT
1 73-13-049	1	Guard panel - large
2 73-13-050	1	Guard panel - small
3 60-01-064	12	Spring
4 60-01-065	6	Hook
5 73-13-051	6	Hook

FLAIL HEAD CASING

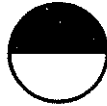

McCOMEL

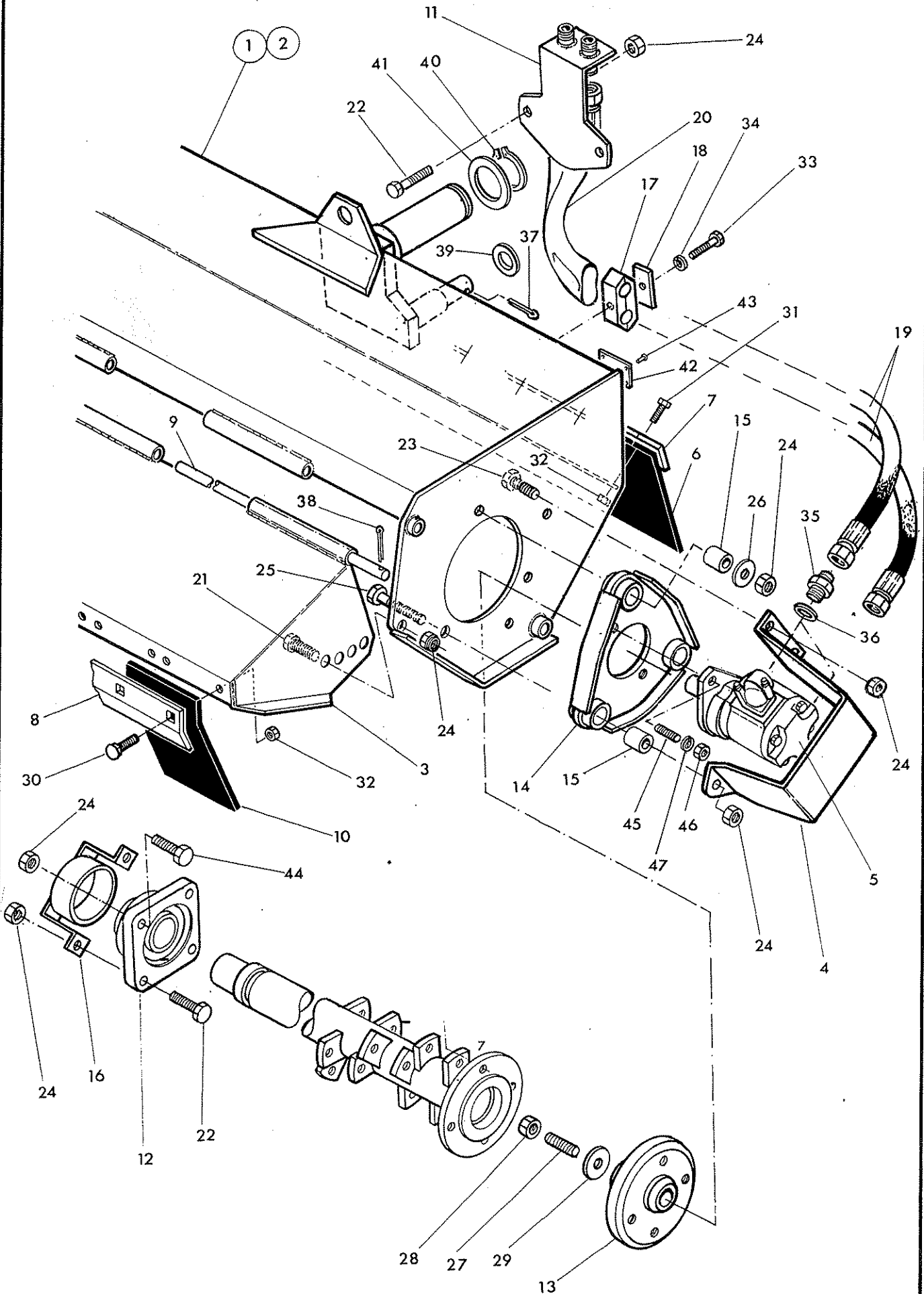



Ref.	Part No.	Qty	Description
FLAIL HEAD CASING			
1	41282.01	1	Casing - L.Hand
2	41282.02	1	Casing - R.Hand - not illus.
3	41283.01	1	Front hood
4	41288.01	1	Motor cover
5	08.785.05	1	Hydraulic motor
6	41289.01	1	Rear flap
7	41290.01	1	Clamp strip - rear
8	41291.01	1	Clamp strip - front
9	41293.01	1	Hood pivot bar
10	41296.01	6	Front flap
11	41297.01	1	Hose bracket
12	03.008.01	1	Flange bearing
13	03.833.01	1	Drive plate
14	09.132.01	1	Motor mounting plate
15	03.871.01	3	Rubber bush
16	06.037.01	1	Bearing cover
17	06.430.09	1	Hose clamp
18	06.418.03	1	Clamp plate
19	85 01 247	2	Hose 5/8 BSPX43 long FS-FS
20	09.868.05	1	Hose sleeve
21	93 13 046	2	Setscrew
22	93 13 086	4	Setscrew
23	93 13 056	2	Setscrew
24	91 43 006	13	Self locking nut
25	92 13 136	3	Bolt
26	02.824.01	2	Washer
27	03.960.02	1	Stud
28	01 41 003	1	Self locking nut
29	03.959.02	1	Plain washer - special
30	92 93 054	12	Cup screw
31	93 13 034	8	Setscrew
32	91 43 004	20	Self locking nut
33	92 13 094	1	Bolt
34	91 00 204	1	Spring washer
35	85 81 270	2	Adaptor
36	86 50 106	2	Bonded seal
37	95 01 406	1	Split pin
38	95 01 325	1	Split pin
39	01 00 109	1	Plain washer
40	04 06 247	1	External circlip
41	10 90 037	1	Retaining washer
42	13 35 246	1	Serial No. Plate
43	71 03 230	4	Pop rivet
44	93 13 076	2	Setscrew
45	04.282.56	2	Stud
46	91.13.005	2	Plain nut
47	91.00.205	2	Spring washer

08.785.02

SEAL KIT - hydraulic motor

ROTOR & FLAIL OPTIONS
ROLLER



McCONEL

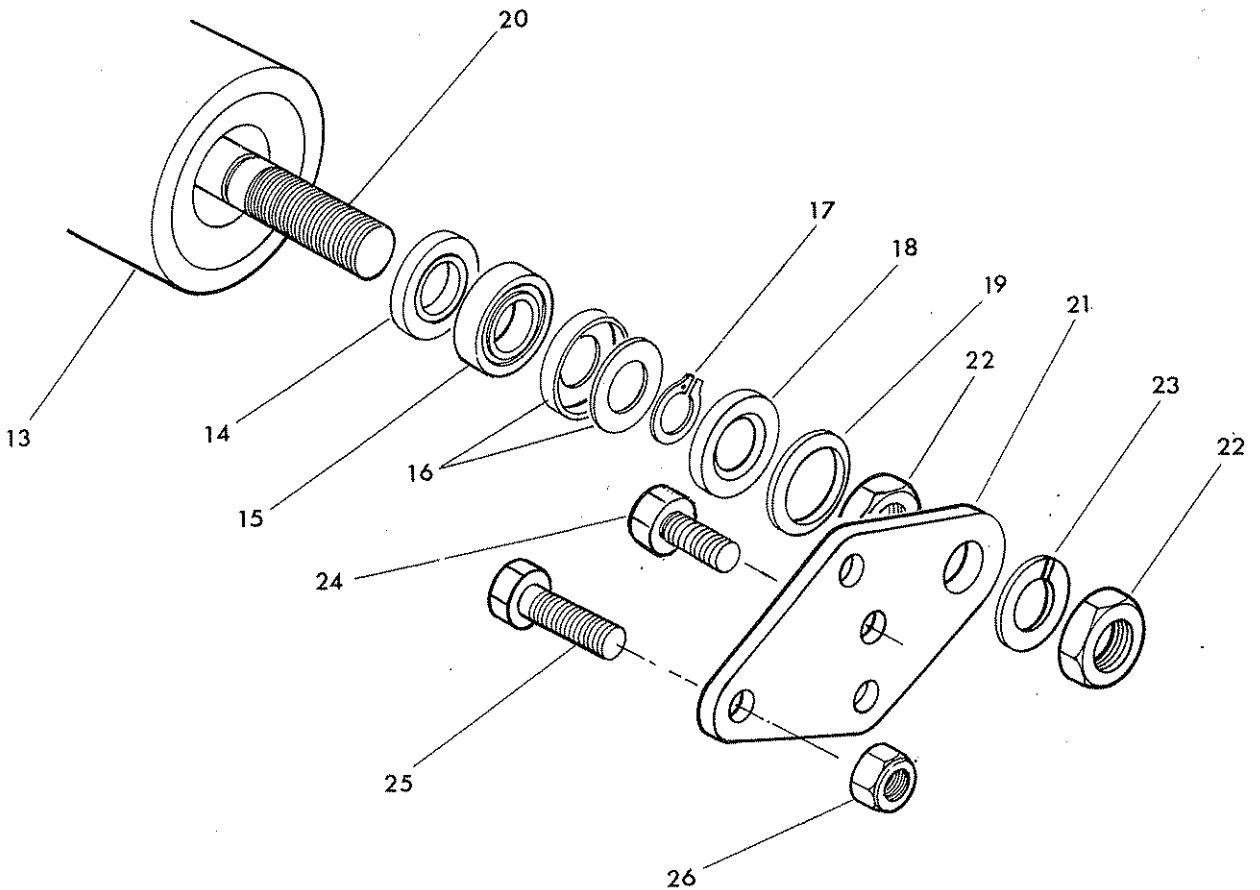
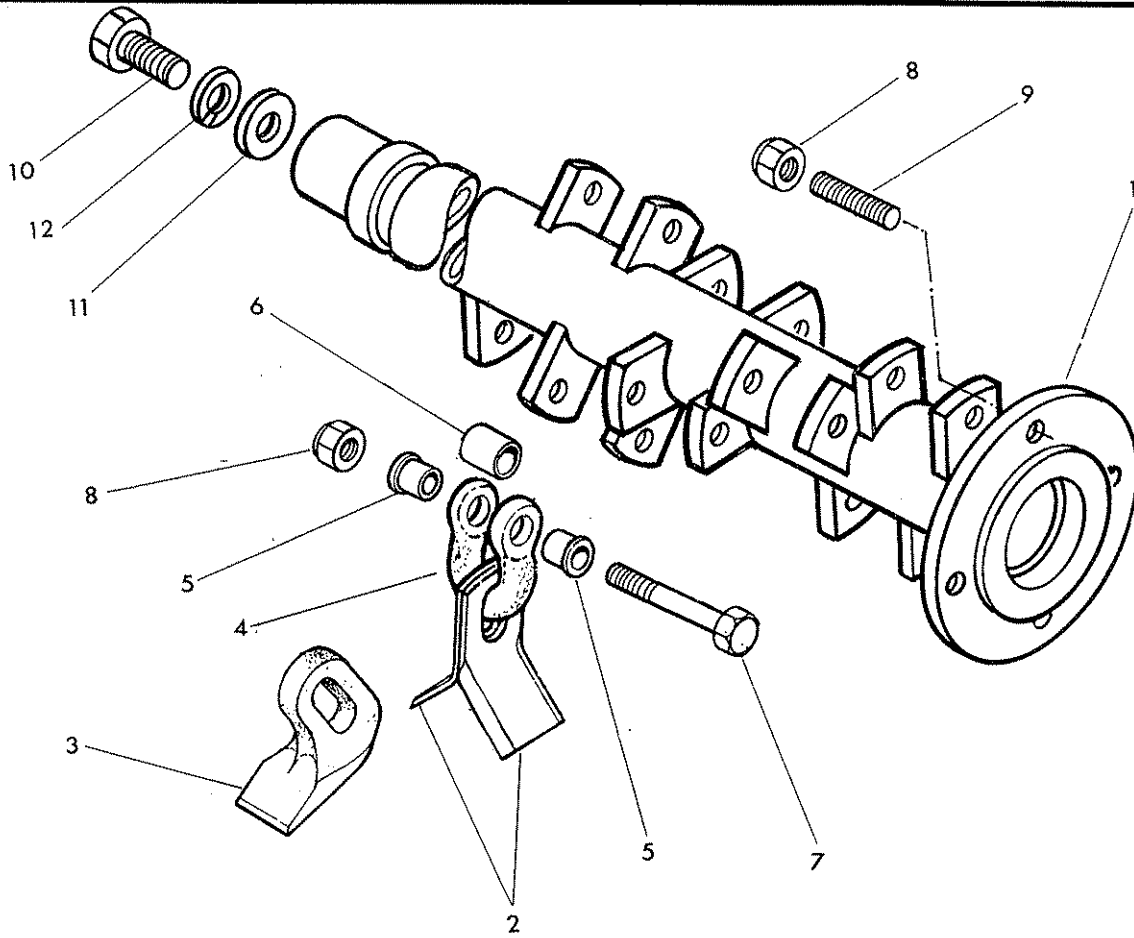



Ref.	Part No.	Qty	Description
ROTOR			
1	41284.01	1	Rotor
2	71 90 166	48	Flail - grass
3	71 90 463	24	Flail - universal
4	05.895.01	24	Shackle
5	02.801.01	48	Collar
6	02.807.01	24	Spacer
7	05.775.02	24	Bolt
8	05.968.02	28	Self locking nut
9	03.917.01	4	Stud
10	93 13 076	1	Setscrew
11	02.824.01	1	Washer - special
12	91 00 206	1	Spring washer

ROLLER			
	41301.01	1	Roller assembly compr:-
13	41301.31	1	Roller
14	04.456.07	2	Seal
15	04.456.11	2	Bearing
16	04.456.06	2	Labyrinth seal
17	04.456.04	2	External circlip
18	04.456.08	2	V seal
19	04.456.05	2	Bearing retainer
20	41301.32	1	Roller shaft
21	41285.01	2	Roller bracket
22	91 13 008	4	Plain nut
23	91 00 208	2	Spring washer
24	93 13 066	2	Setscrew
25	93 13 086	2	Setscrew
26	91.43.006	4	Self locking nut

CUTTERBAR DRIVE



McCOMEL

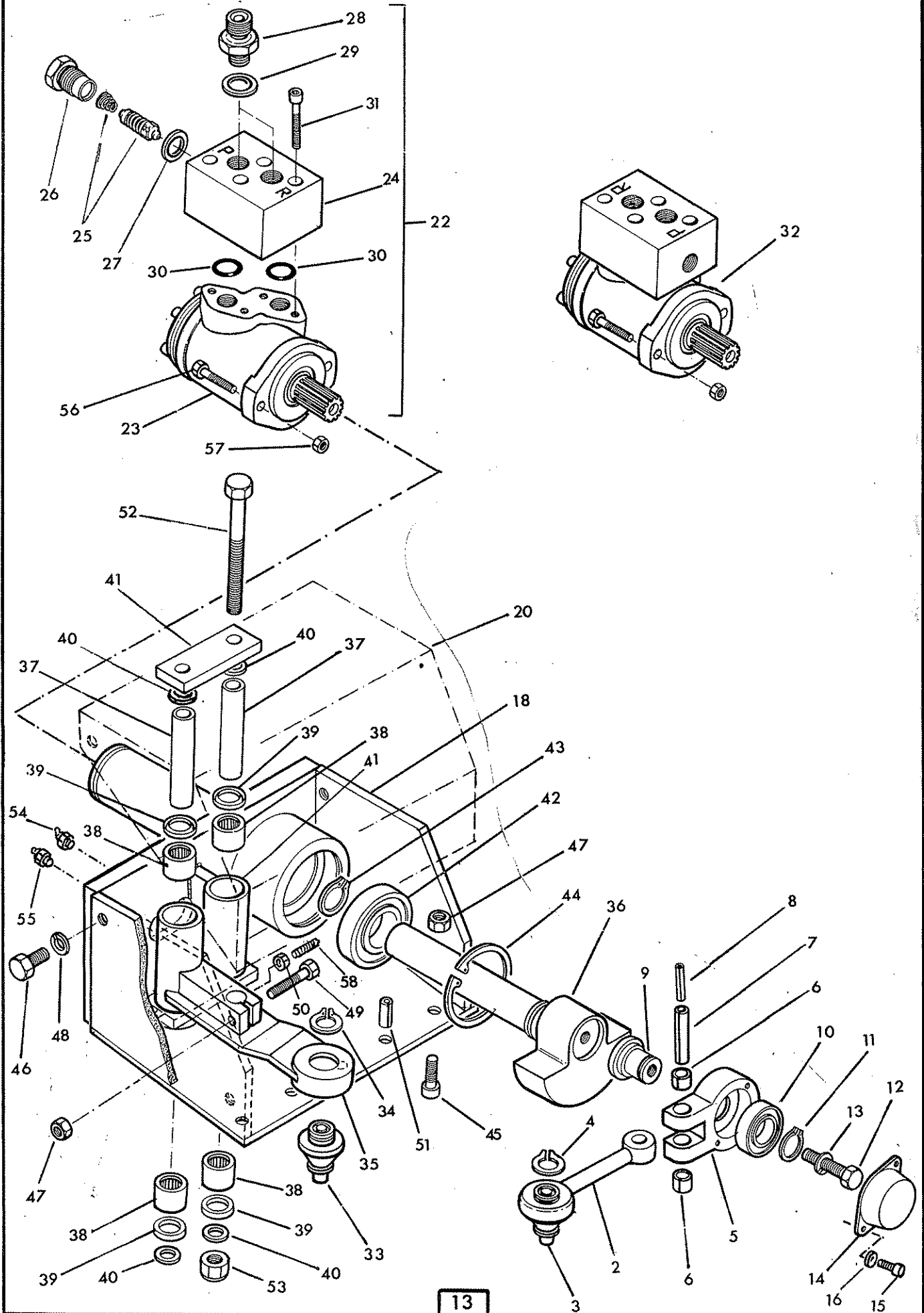

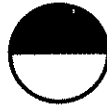

MCCORMEL

Ref. Part No.	Qty	Description
CUTTERBAR MOUNTING AND DRIVE		
1	41.075.01	1 Con rod - L.Hand compr:-
2		1 Con rod shaft
3	10 90 058	1 Swivel
4	04 01 225	1 External circlip
5	10 90 056	1 Bearing housing
6	10 90 059	2 Bush
7	10 90 060	1 Spring dowel
8	10 90 061	1 Spring dowel
9	10 90 057	1 Spigot
10	06 00 074	1 Bearing
11	04 01 230	1 External circlip
12	92 13 116	1 Bolt
13	91 00 206	1 Spring washer
14	10 90 054	1 Bearing cap
15	93 43 023	2 Capscrew
16	91 00 203	2 Spring washer
17	41.075.02	1 Con rod-R.Hand-not illus.components as L.Hand
18	41261.01	1 Mounting bracket - L.Hand
19	41261.02	1 Mounting bracket - R.Hand - not illus.
20	41264.01	1 Drive cover - L.Hand
21	41264.02	1 Drive cover - R.Hand - not illus.-
22	41336.01	1 Motor assy. L.Hand compr:-
23	83 01 293	1 Motor
24	41360.01	1 Valve plate
25	81 30 151	1 Relief valve
26	81 30 032	1 Relief valve cap
27	86 50 103	1 Bonded seal
28	G381.2120	2 Adaptor
29	86 50 104	2 Bonded seal
30	86 00 403	2 'O' ring
31	93 43 104	4 Capscrew
32	41336.02	1 Motor assy. R.Hand - components as L.Hand
33	10 90 058	1 Swivel
34	04 01 230	1 External circlip
35	41263.01	1 Rocker arm
36	41266.01	1 Crankshaft
37	41242.01	2 Sleeve
38	06 00 102	4 Bearing
39	86 29 212	4 Sealing ring
40	41275.01	4 Thrust washer
41	41262.01	2 Control link
42	06 00 073	1 Bearing
43	04 02 235	1 External circlip
44	04 11 272	1 Internal circlip
45	93 53 075	3 Capscrew
46	93 13 035	4 Setscrew
47	91 43 005	4 Self locking nut
48	91 00 205	4 Spring washer
49	93 43 105	1 Capscrew
50	91 13 004	1 Plain nut
51	04 28 120	2 Spring dowel
52	92 13 286	2 Bolt
53	91 43 006	2 Self locking nut
54	09 01 124	1 Greaser
55	09 01 121	1 Greaser
56	02 11 165	2 Bolt
57	01 41 005	2 Self locking nut
58	93 63 054	1 Grubscrew
		1
86 99 246		SEAL KIT -hydraulic motor

CUTTERBAR



McCORMICK

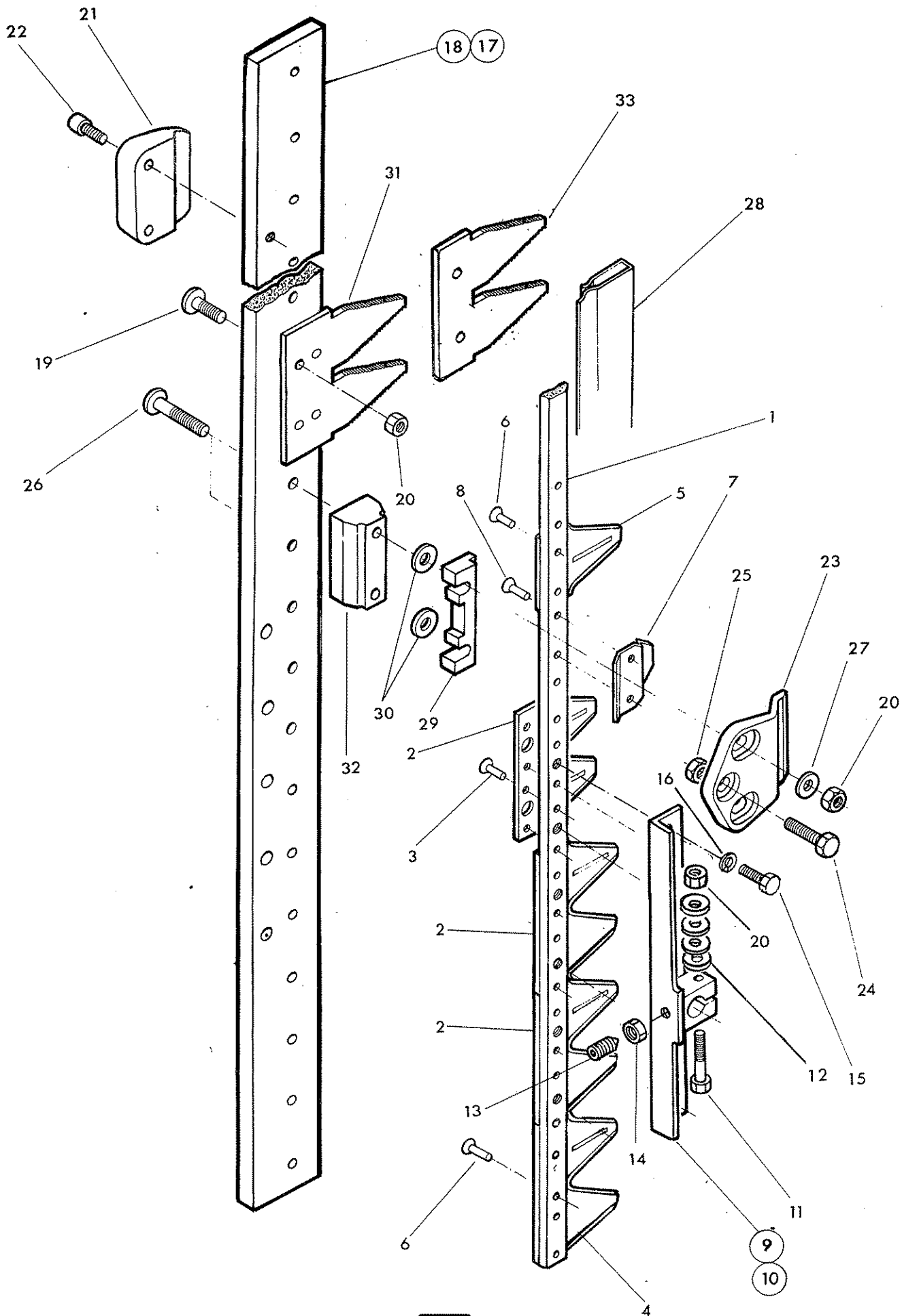

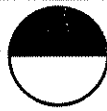

Ref.	Part No.	Qty	Description
			CUTTERBAR ASSEMBLIES
	41.074.03	1	Knife assembly
1	41470.01	1	Knife back
2	41471.01	3	Knife section-double-knife heel pos.
3	10 90 062	12	Rivet
4	41471.02	11	Knife section - double
5	41471.03	1	Knife section - single
6	10 90 063	36	Rivet
7	41472.01	5	Abutment plate
8	10 90 064	20	Rivet
9	41.076.02	1	Knife heel - R.hand
10	41.076.01	1	Knife heel - L.hand
11	92 13 104	1	Setscrews
12	10 90 119	4	Disc spring
13	93 63 044	1	Grubscrew
14	91 13 004	2	Plain nut
15	41477.01	4	Setscrew
16	91 00 204	4	Spring washer
17	41.078.04	1	Fingerbar - R.hand - not illus.
18	41.078.03	1	Fingerbar - L.hand
19	10 90 073	20	Dome headed bolt
20	91 43 004	30	Self locking nut
21	41475.01	1	Slide plate
22	91 43 024	2	Capscrew
23	41476.01	5	Knife clip
24	93 13 064	5	Setscrew
25	91 13 004	5	Plain nut
26	10 90 077	10	Dome headed bolt
27	10 90 079	10	Washer
28	10 90 152	1	Knife guard

CUTTERBAR ASSEMBLY - UNIVERSAL ONLY

29	41473.01	5	Abutment block
30	10 90 078	10	Washer
31	41474.01	15	Finger

CUTTERBAR ASSEMBLY - GRASS ONLY

32	41473.02	5	Abutment block
33	41474.02	15	Finger

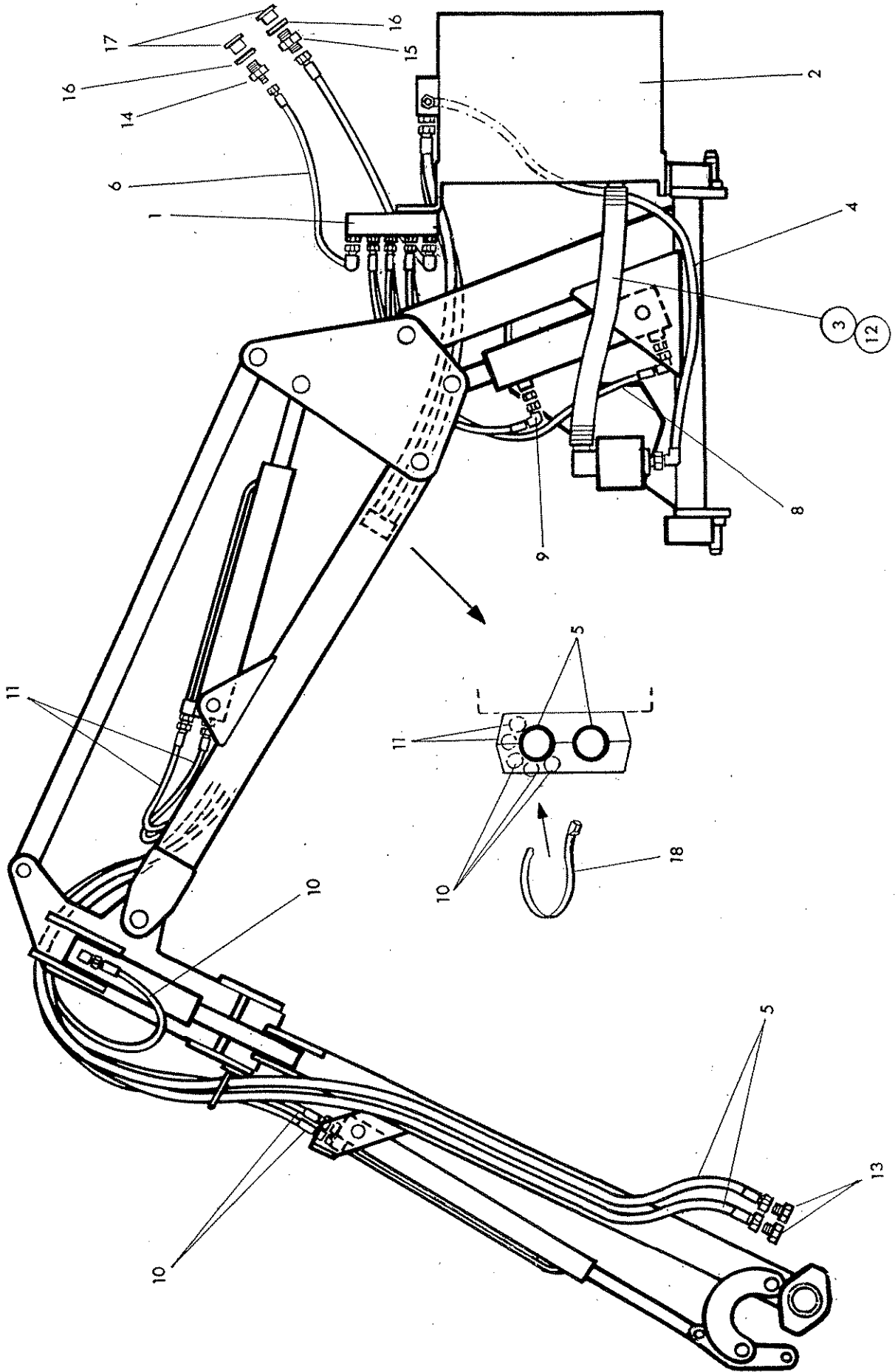

HOSE INSTALLATION – Si Models

REF.	QTY.	PART No.	DESCRIPTION	
		41320.01	HOSE INSTALLATION KIT - Si Models	
1	1		Control Valve	
2	1		Tank	
3	1	8501139	Hose 1 1/4" x 24 long	Suction
4	1	8501250	Hose 5/8" BSP x 52 long FS-F135	Pump to Tank
5	2	8501249	Hose 5/8" BSP x 140 long FS-FS	Flail Hoses
6	1	8531323	Hose 3/8" BSP x 80 long SF-90F	Supply
7	1	8532014	Hose 1/2" BSP x 80 long SF-90F	Return
8	1	8535042	Hose 1/4" BSP x 40 long SF-90F	Lift Base
9	1	8535082	Hose 1/4" BSP x 34 long SF-90F	Lift Gland
10	3	10.001.33	Hose 1/4" BSP x 2300 long SF-SF	Angle & B/way
11	2	8515132	Hose 1/4" BSP x 64 long SF-SF	Reach
12	4	0904107	Hose Clip	
13	2	G3812119	Blanking Cap	
14	1	6000112	Adaptor - MM	
15	1	8581110	Union	
16	2	8650104	Bonded Seal	
17	2	ST134	Plastic Blanking Cap	
18	<i>as req'd</i>	7196045	Hose Tie 300 long	

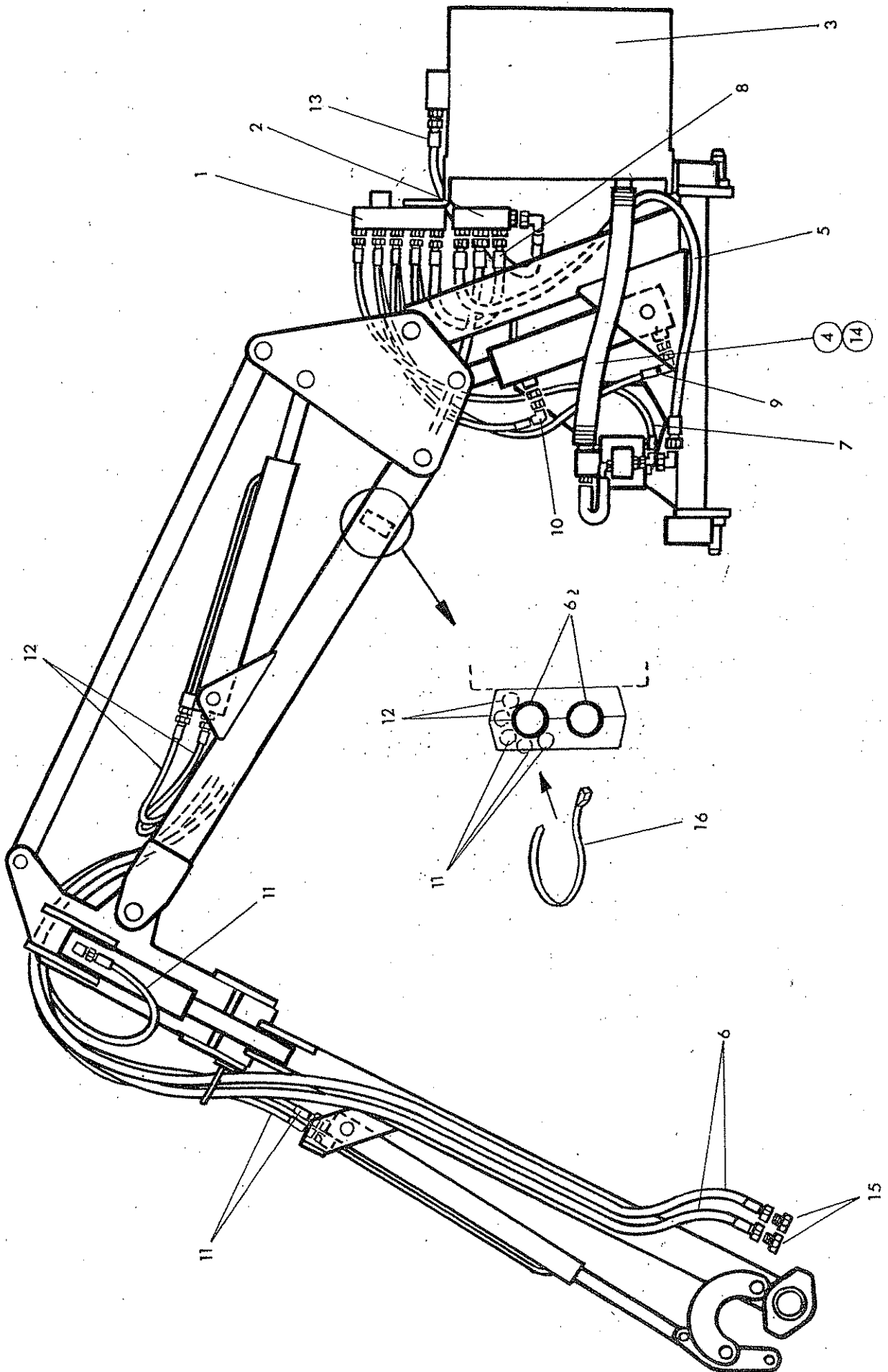



HOSE INSTALLATION – Ti Models

REF.	QTY.	PART No.	DESCRIPTION
ALL TI MODELS			
1	1		Control Valve
2	1		Rotor Control Valve
3	1		Tank
		41320.07	CABLE TI HOSE KIT - L/H Build (R/H Front Mount)
4	1	8501307	Hose 1 1/4" x 560 long Suction
5	1	10.008.12	Hose 5/8" BSP x 600 long FS/F90 Pump to RCV
6	2	8501249	Hose 5/8" BSP x 140 long FS/FS Flail Hoses
7	1	8531243	Hose 3/8" BSP x 51 long FS/F90 Pump to Valve
8	1	8533144	Hose 1/2" BSP x 22 long FS/F90 Valve to RCV
9	1	8535042	Hose 1/4" BSP x 40 long FS/F90 Lift Base
10	1	8535082	Hose 1/4" BSP x 34 long FS/F90 Lift Gland
11	3	10.001.33	Hose 1/4" BSP x 2300 long FS/FS Angle & B/way
12	2	8515132	Hose 1/4" BSP x 64 long FS/FS Reach
13	1	10.008.22	Hose 5/8" BSP x 1200 long FS/F90 RCV to Tank
		41320.08	CABLE TI HOSE KIT - R/H Build (L/H Front Mount)
4	1	8501307	Hose 1 1/4" x 560 long Suction
5*	1	10.008.12	Hose 5/8" BSP x 600 long FS/F90 Pump to RCV
6	2	8501249	Hose 5/8" BSP x 140 long FS/FS Flail Hoses
7	1	8531403	Hose 3/8" BSP x 40 long ST-90 Pump to Valve
8	1	8533144	Hose 1/2" BSP x 22 long FS/F90 Valve to RCV
9	1	8535042	Hose 1/4" BSP x 40 long FS/F90 Lift Base
10	1	8535082	Hose 1/4" BSP x 34 long FS/F90 Lift Gland
11	3	10.001.33	Hose 1/4" BSP x 2300 long FS/FS Angle & B/way
12	2	8515132	Hose 1/4" BSP x 64 long FS/FS Reach
13*	1	10.008.12	Hose 5/8" BSP x 600 long FS/F90 RCV to Tank
* NOTE: For Right Hand build machines items 5 & 13 are identical, therefore Kit 41320.08 contains 2 x hose 10.008.12			
		41320.09	ELECTRIC TI HOSE KIT - L/H & R/H Build
4	1	8501307	Hose 1 1/4" x 560 long Suction
5	1	10.008.12	Hose 5/8" BSP x 600 long FS/F90 Pump to RCV
6	2	8501249	Hose 5/8" BSP x 140 long FS/FS Flail Hoses
7	1	8531403	Hose 3/8" BSP x 40 long ST-90 Pump to Valve
8	1	8533144	Hose 1/2" BSP x 22 long FS/F90 Valve to RCV
9	1	8535042	Hose 1/4" BSP x 40 long FS/F90 Lift Base
10	1	8535082	Hose 1/4" BSP x 34 long FS/F90 Lift Gland
11	3	10.001.33	Hose 1/4" BSP x 2300 long FS/FS Angle & B/way
12	2	8515132	Hose 1/4" BSP x 64 long FS/FS Reach
13	1	10.008.22	Hose 5/8" BSP x 1200 long FS/F90 RCV to Tank
ALL TI MODELS			
14	4	0904107	Hose Clip
15	2	G3812119	Blanking Cap
16	as req'd	7196045	Hose Tie

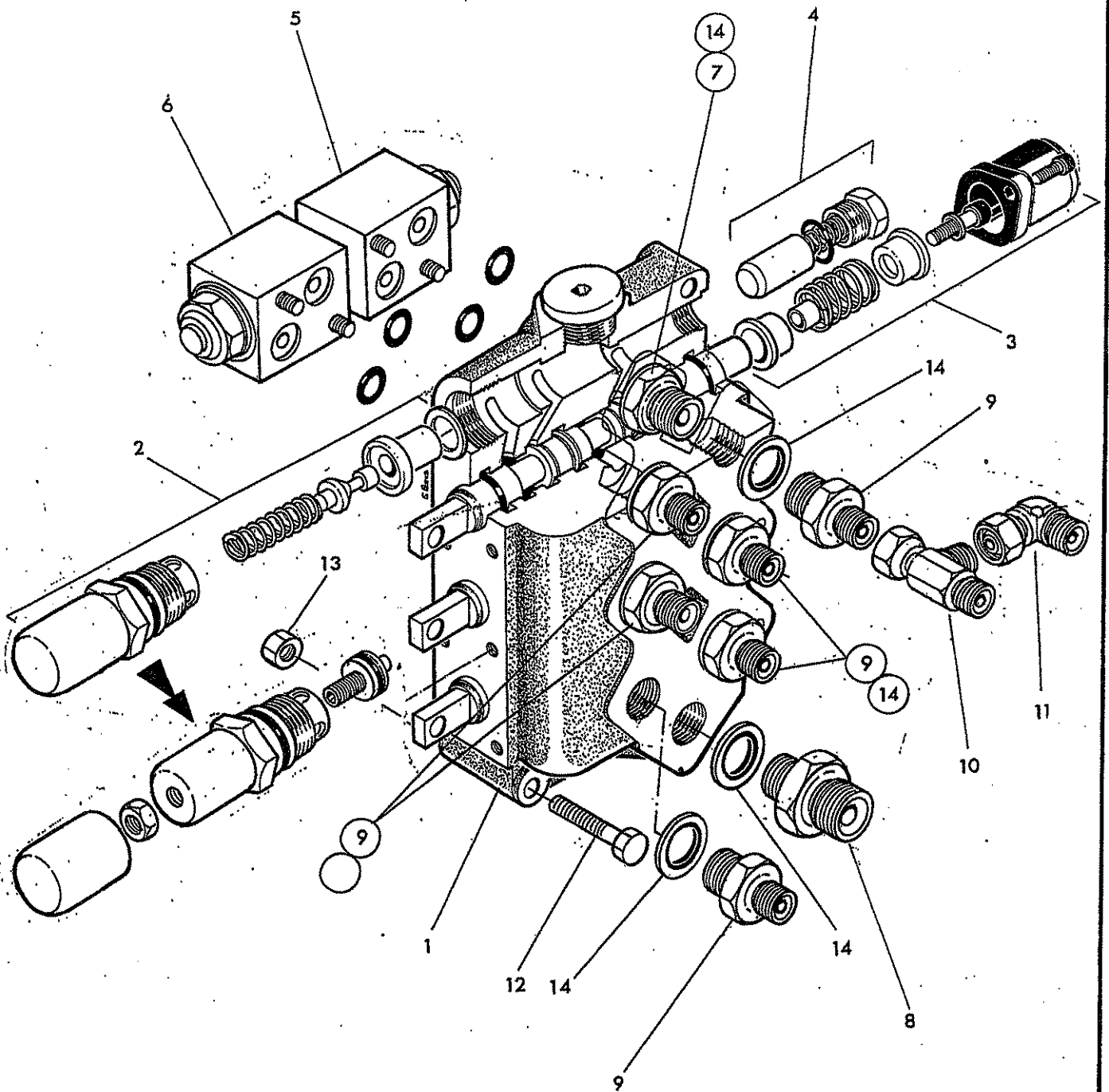

MCCORMICK

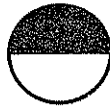



Ref. Part No.	Qty	Description
CONTROL VALVE ASSEMBLY		
1 81 30 324	1	Control valve:
2 G381 2539	1	Main relief valve 160 Bar (2300 Psi)
3 81 30 134	3	Centering spring assembly
4 81 30 022	1	Non return valve assembly
5 81 28 022	1	Service relief valve 175 Bar - Lift base
6 81 28 065	1	Service relief valve 40 Bar Lift gland
7 60 00 113	1	Adaptor 3/8 BSP MM
8 60 00 112	1	Adaptor 3/8 BSP 1/2 BSP MM
9 85 81 115	6	Adaptor 3/8 BSP 1/4 BSP MM
10 85 81 254	1	Tee connector 1/4 BSP MFM
11 85 81 190	1	Elbow-swivel 1/4 BSP MF
12 92 13 144	2	Bolt M8X70
13 91 43 004	2	Self locking nut M8
14 86 50 103	8	Bonded seal 3/8 BSP
86 99 163		SEAL KIT
87 00 510	4	'O' ring

CONTROL VALVE – Ti ELECTRIC

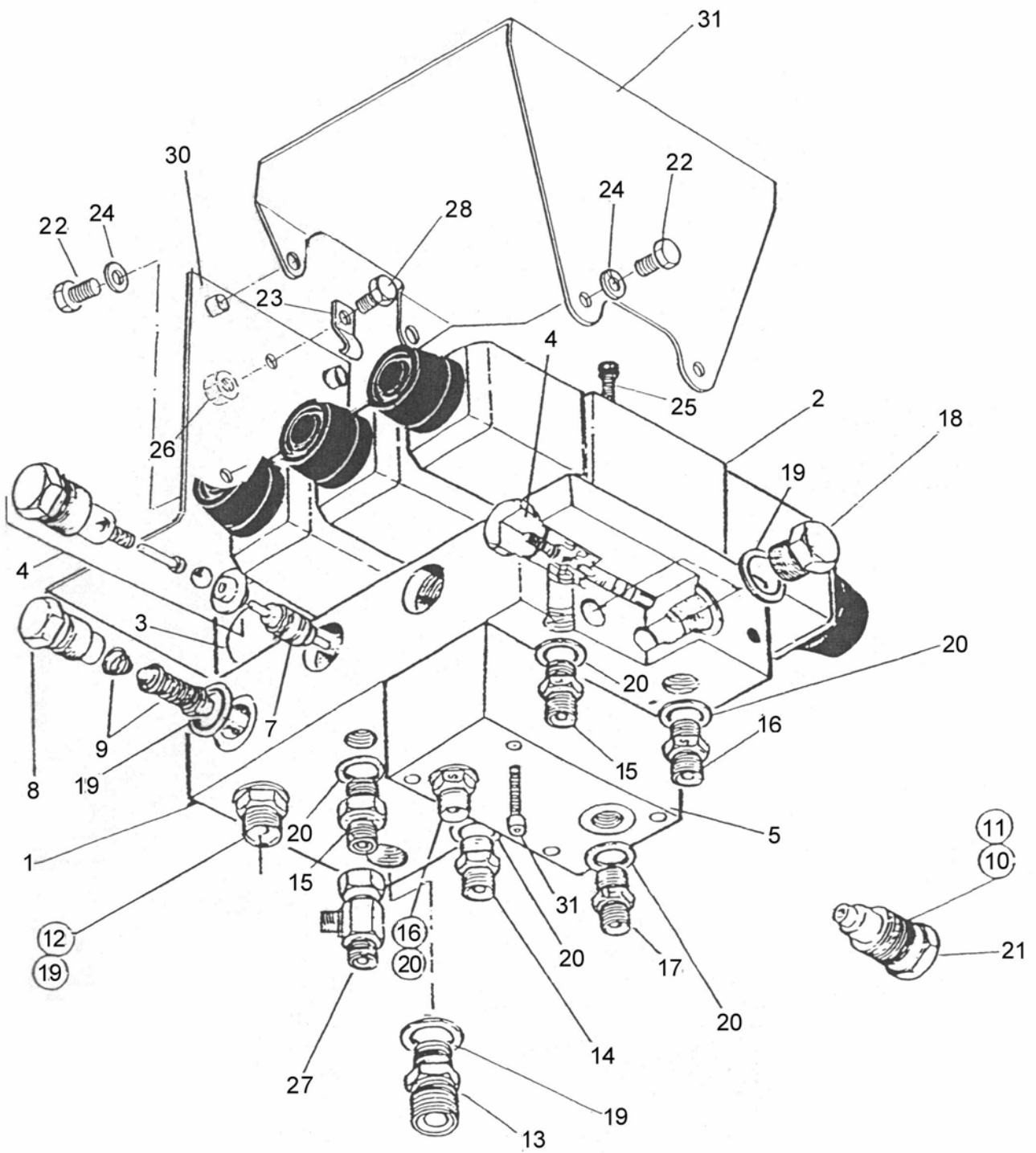

CONTROL VALVE – Ti ELECTRIC

REF.	QTY.	PART No.	DESCRIPTION
		7490787	ELECTRIC TI CONTROL VALVE ASSEMBLY
1	1	8130321	Manifold Block
2	3	8130629	Double Solenoid Valve
3	1	8130456	Single Solenoid Valve
4	5	8130090	Check Valve Assembly
5	1	8130322	Hose Plate
6	4	9243082	Capscrew
7	3	8130087	Actuator
8	1	8130032	Relief Valve Cap
9	1	8130142	Relief Valve c/w Spring (160BAR)
10	1	8709644	Anti Extrusion Ring
11	1	8700644	'O' Ring
12	1	6000113	Union
13	1	6000112	Adaptor
14	1	8581169	Union
15	2	8130038	Restrictor Union
16	2	8130037	Restrictor Union
17	1	8130103	Restrictor Union
18	2	8003001	Plug
19	5	8650103	Seal
20	6	8650102	Seal
21	1	8130078	Plug
22	4	9313034	Setscrew
23	1	7109151	Cable Clamp
24	4	9100204	Washer
25	16	9243062	Capscrew
26	7	9143004	Nut
27	1	8581254	Tee
28	7	9343044	Bolt
29	1	41844.02	Loom
30	1	43497.01	Valve Mounting Plate
31	1	7194277	Valve Cover

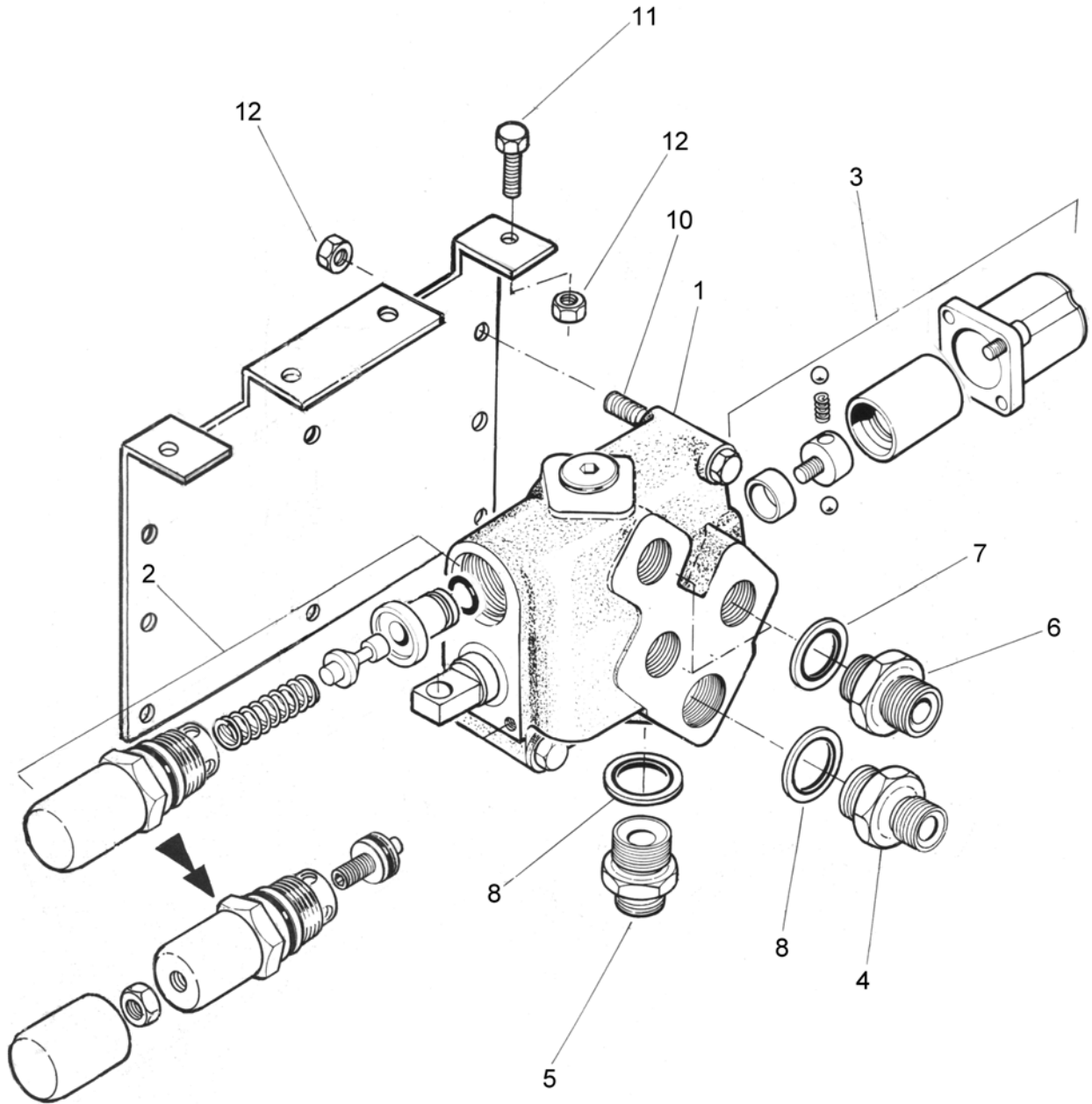

**ROTOR CONTROL VALVE (Ti only)**

REF.	QTY.	PART No.	DESCRIPTION
			ROTOR CONTROL VALVE ASSEMBLY
1	1	8125343	Rotor Control Valve <i>inc:</i>
2	1	8125095	Relief Valve - 3000 psi (210 bar)
3	1	8125109	Spool Detent Assembly
4	1	8581130	Adaptor
5	1	8581270	Adaptor
6	3	8581180	Adaptor
7	3	8650104	Bonded Seal
8	2	8650106	Bonded Seal
9	1	41328.01	Mounting Bracket
10	3	9213164	Bolt
11	2	9313044	Setscrew
12	5	9143004	Self Locking Nut
		8699218	SEAL KIT

PROPORTIONAL ACV/ELEC. RRV

Module:
8130670

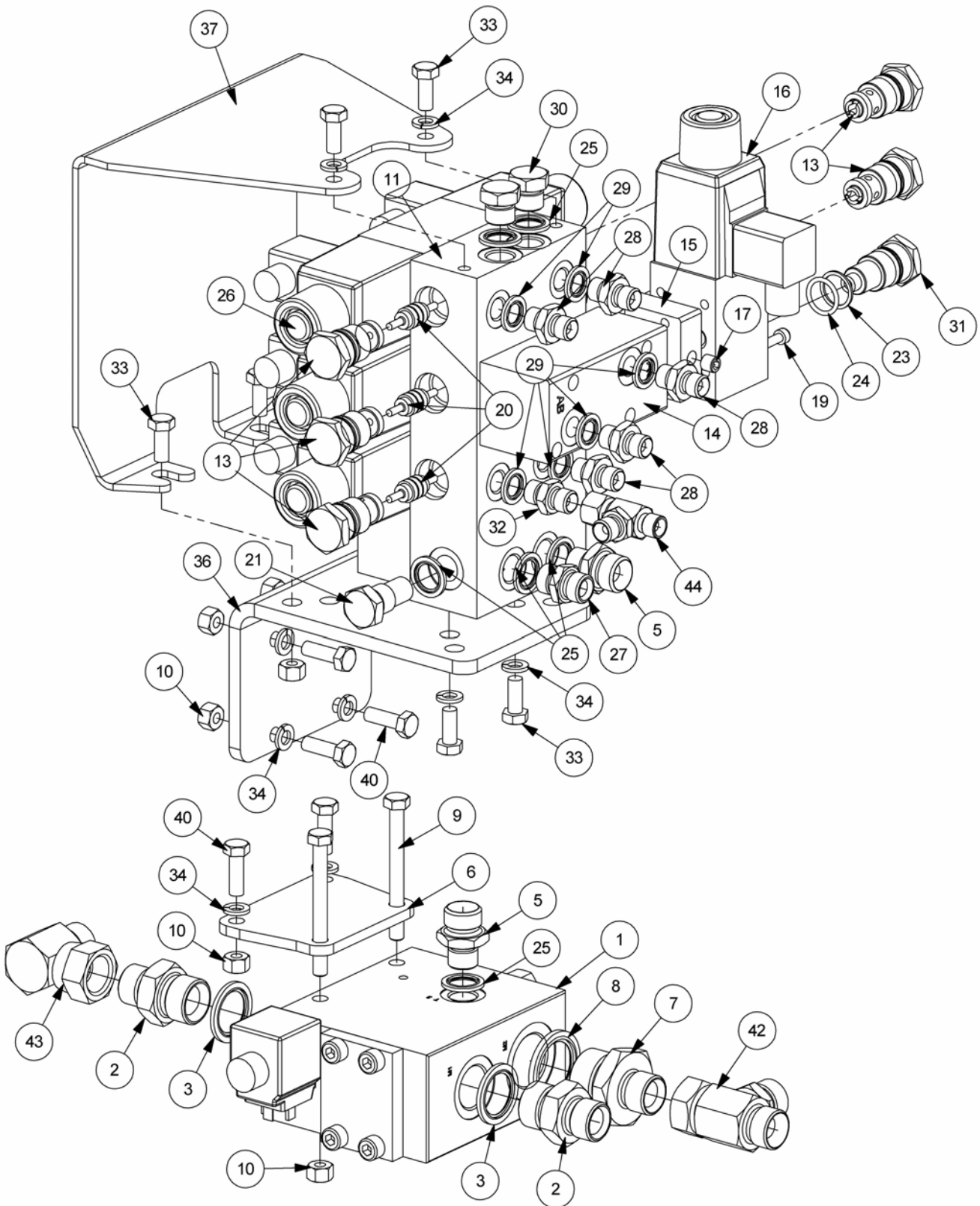



PROPORTIONAL ACV/ELEC. RRV

REF.	QTY.	PART No.	DESCRIPTION
		8130670	PROPORTIONAL ACV / ELEC. RRV
1	1	08.943.01	RELIEF VALVE / DIVERTER
2	2	8581270	ADAPTOR
3	2	8650106	BONDED SEAL
4	1	8581436	PLUG - SOFT SEAL
5	2	6000112	ADAPTOR
6	1	21476.01	RRV BRACKET
7	1	8581378	ADAPTOR
8	1	8650108	BONDED SEAL
9	2	9213164	BOLT
10	11	9143004	SELF-LOCKING NUT
11	1	8130321	BLOCK - 3 FUNCTION MANIFOLD
12	1	8130456	CUT OFF SOLENOID VALVE
13	5	8130090	CHECK VALVE ASSEMBLY
14	1	8130323	FLOAT VALVE BLOCK
15	1	8126280	BRIDGING PLATE
16	1	8130457	SOLENOID VALVE - SINGLE
17	1	8582041	TAPER PLUG
18	4	9243082	CAPSCREW
19	4	9243102	CAPSCREW
20	3	8130087	ACTUATOR
21	1	8130032	RELIEF VALVE CAP
22	1	8130142	RELIEF VALVE - 160BAR
23	1	8709644	BACK UP RING
24	1	8700644	O RING - METRIC
25	6	8650103	BONDED SEAL
26	3	41784.48	DOUBLE SOLENOID PROP. VALVE
27	1	6000113	ADAPTOR
28	5	8581169	ADAPTOR
29	6	8650102	BONDED SEAL
30	2	8003001	ADAPTOR PLUG
31	1	8130078	CHECK VALVE CAP
32	1	8130038	ADAPTOR RESTRICTOR - 1.4 'L'
33	7	9313044	SETSCREW
34	10	9100204	SPRING WASHER
35	16	9243062	CAPSCREW
36	1	43497.01	VALVE MOUNTING PLATE
37	1	7194277	VALVE COVER
38	1	41844.02	LOOM - 14 CORE PLUG IN
39	1	7313282	CAB MOUNTING KIT
40	6	9313054	SETSCREW
41	1	8402338	LOOM - ANGLE FLOAT
42	1	8581460	ADAPTOR TEE
43	1	8581338	ADAPTOR
44	1	8581254	ADAPTOR TEE

ROTOR SWITCHBOX & RRV

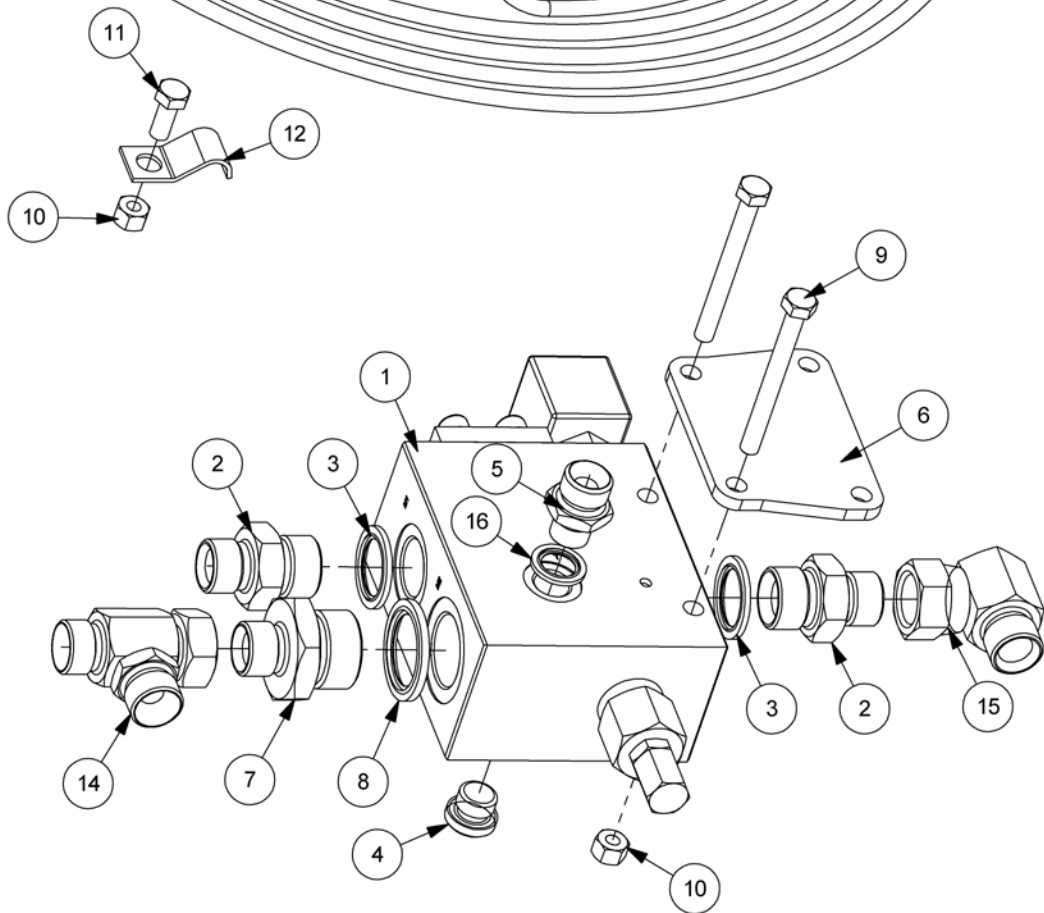
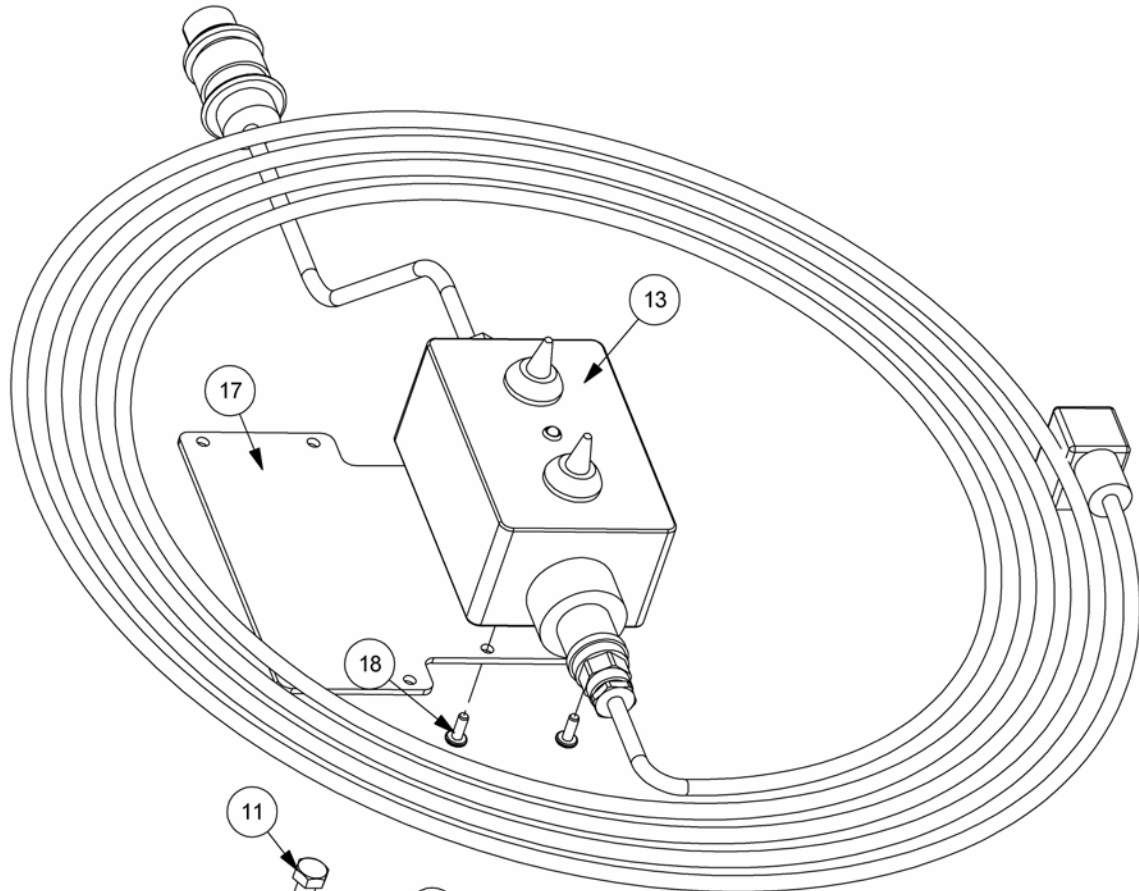
Module:
41351.03 (Component part of Module 8130670)



**ROTOR SWITCHBOX & RRV**

REF.	QTY.	PART No.	DESCRIPTION
		41351.03	PA32 ROTOR SWITCHBOX & RRV
1	1	08.943.01	RELIEF VALVE / DIVERTER
2	2	8581270	ADAPTOR
3	2	8650106	BONDED SEAL
4	1	8581436	PLUG (SOFT SEAL)
5	1	6000112	ADAPTOR
6	1	21476.01	RRV BRACKET
7	1	8581378	ADAPTOR
8	1	8650108	BONDED SEAL
9	2	9213164	BOLT
10	3	9143004	SELF-LOCKING NUT
11	1	9313044	SETSCREW
12	1	7109151	CABLE CLAMP
13	1	41351.03	SWITCH BOX & LOOM
14	1	8581460	ADAPTOR TEE
15	1	8581338	ADAPTOR - 90°
16	1	8650103	BONDED SEAL
17	1	42442.02	BRACKET - ROTOR SWITCH BOX
18	4	2800243	SELF TAPPING SCREW

CONTROL LEVERS & CABLES

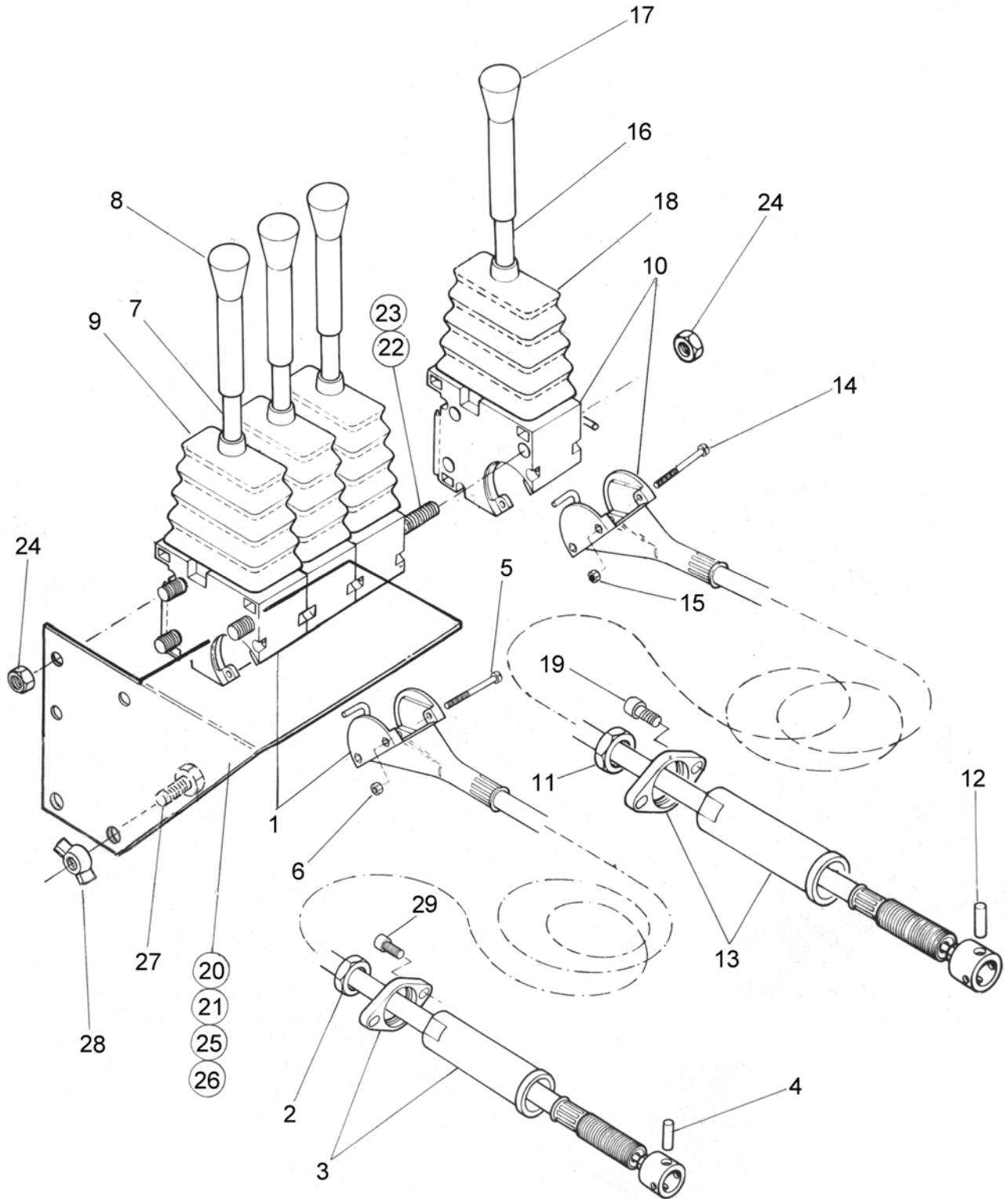



CONTROL LEVERS & CABLES

REF.	QTY.	PART No.	DESCRIPTION
			CONTROL LEVERS AND CABLES
			LEVER & CABLE ASSEMBLY (Lift/Reach/Angle)
1	3	8017054	
2	1	8017014	Locknut
3	1	8017013	Flange and Sleeve
4	1	8017016	Spool Eye Pin
5	2	9373081	Screw
6	2	9113001	Nut
7	1	8017023	Lever
8	1	8017027	Knob
9	1	8017026	Weather Gaiter
10	1	8017045	** LEVER & CABLE ASSEMBLY (Rotor Control)
11	1	8017014	** Locknut
12	1	8017021	** Pin
13	1	8017018	** Flange and Sleeve
14	2	9373081	** Screw
15	2	9113001	** Nut
16	1	8017023	** Lever
17	1	09.968.99	** Knob
18	1	8017026	** Weather Gaiter
19	2	9343023	** Capscrew
20	1	09.970.01	** Mounting Bracket - 4 Lever L/H
21	1	09.970.02	** Mounting Bracket - 4 Lever R/H
22	3	04.282.70	** Tie Rod - 4 Lever
23	3	04.282.73	* Tie Rod - 3 Lever
24	3	9143003	Self Locking Nut
25	1	41.181.01	* Mounting Bracket - 3 Lever L/H
26	1	41.181.02	* Mounting Bracket - 3 Lever R/H
27	2	9313034	Setscrew
28	2	9193004	Wingnut
29	6	9343022	Capscrew

* ***Si Models only***

** ***Ti Models only***

MONOLEVER CONTROL & LOOM

MODULE:
8402905

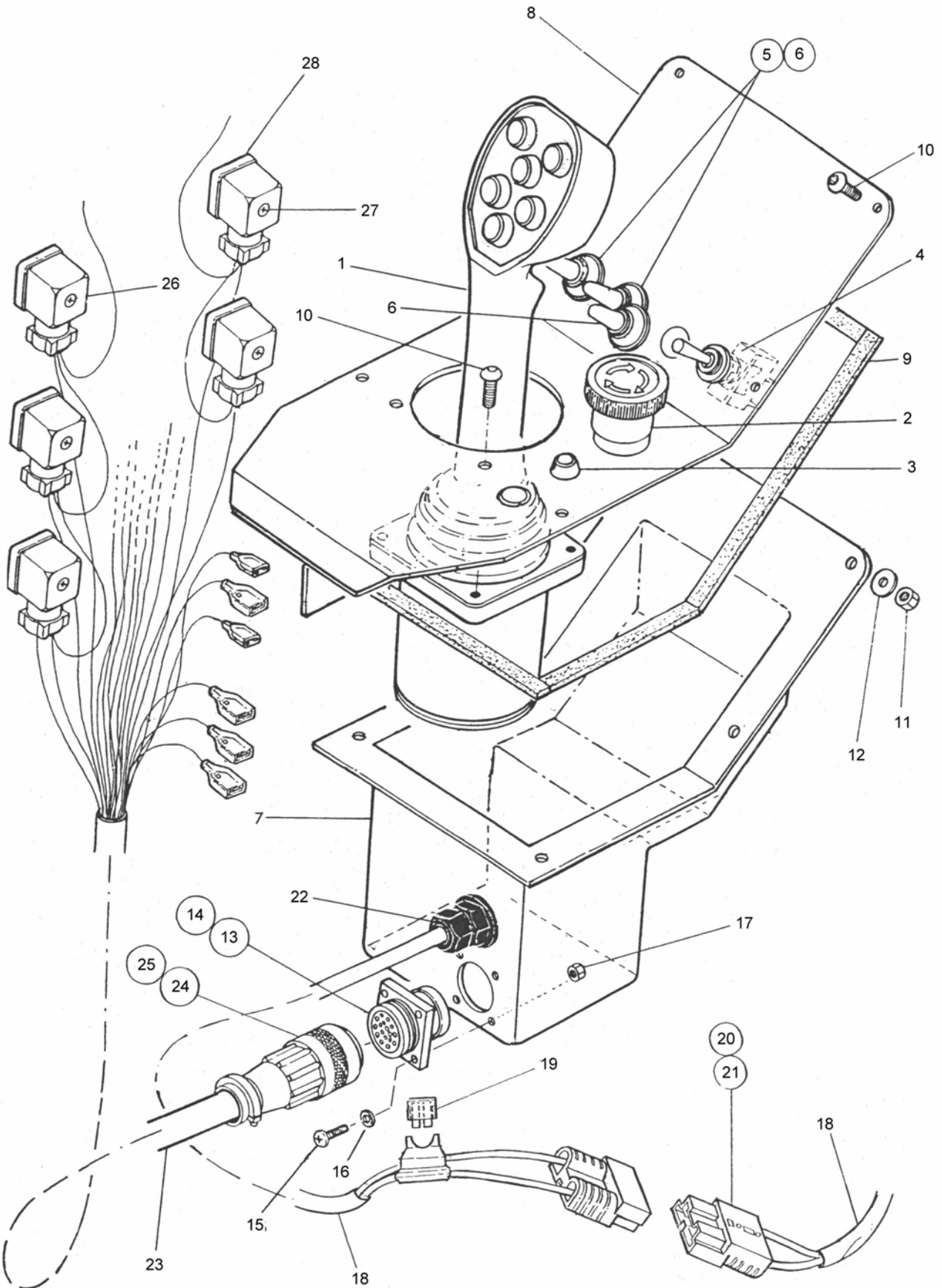

MONOLEVER CONTROL & LOOM

REF.	QTY.	PART NO.	DESCRIPTION
		41590.03	MONOLEVER 6 BUTTON CONTROL ASSEMBLY
1	1	41590.32	Joystick - including Circuit Board
2	1	8402184	Power On/Emergency Stop
3	1	8402174	L.E.D. Main Power On
4	1	8402182	Switch - Slew/Auto Reset
5	2	8402023	Switch - Lift and Angle Float
6	3	8402024	Weather Cover
7	1	7550300	Cover Pod
8	1	7550339	Top Plate
9	1	7290052	Sealing Strip (<i>cut to suit</i>)
10	10	9300125	Screw - Button Head
11	6	9143003	Self Locking Nut
12	6	9100103	Washer
13	1	8402189	Socket Shell
14	14	8402192	Socket Pin - Female
15	4	9200007	Screw - Posidrive Panhead
16	4	9100400	External Serrated Washer
17	4	9100013	Nut - Plated
18	1	8402232	Power Loom <i>inc:</i>
19	1	43034.03	Fuse
20	2	8402230	Contact Housing
21	4	8402229	Contacts
22	1	8402042	Gland
23	1	41844.01	Wiring Loom <i>inc:</i>
24	1	8402188	Shell
25	1	8402190	Cable Clamp
26	12	07.835.04	Plug <i>inc:</i>
27	1	07.835.03	Screw
28	1	07.835.02	Gasket
29	1	8402193	Special Tool

CONTROL BOX - Mini Single Lever

Modules:

- 8402390 – 3 Service B/B 2 Switch
- 8402391 – 3 Service Prop. B/B 2 Switch
- 8402392 – 3 Service Prop. B/B 3 Switch
- 8402393 – 3 Service Prop. 3 Switch

8402393 Illustrated

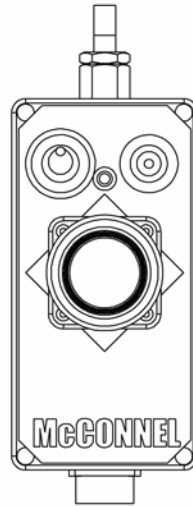

8402390 & 8402391

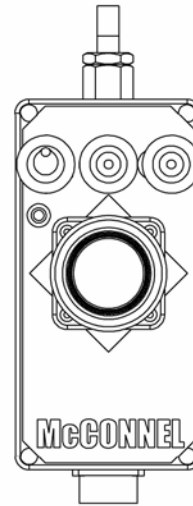

8402392 & 8402393

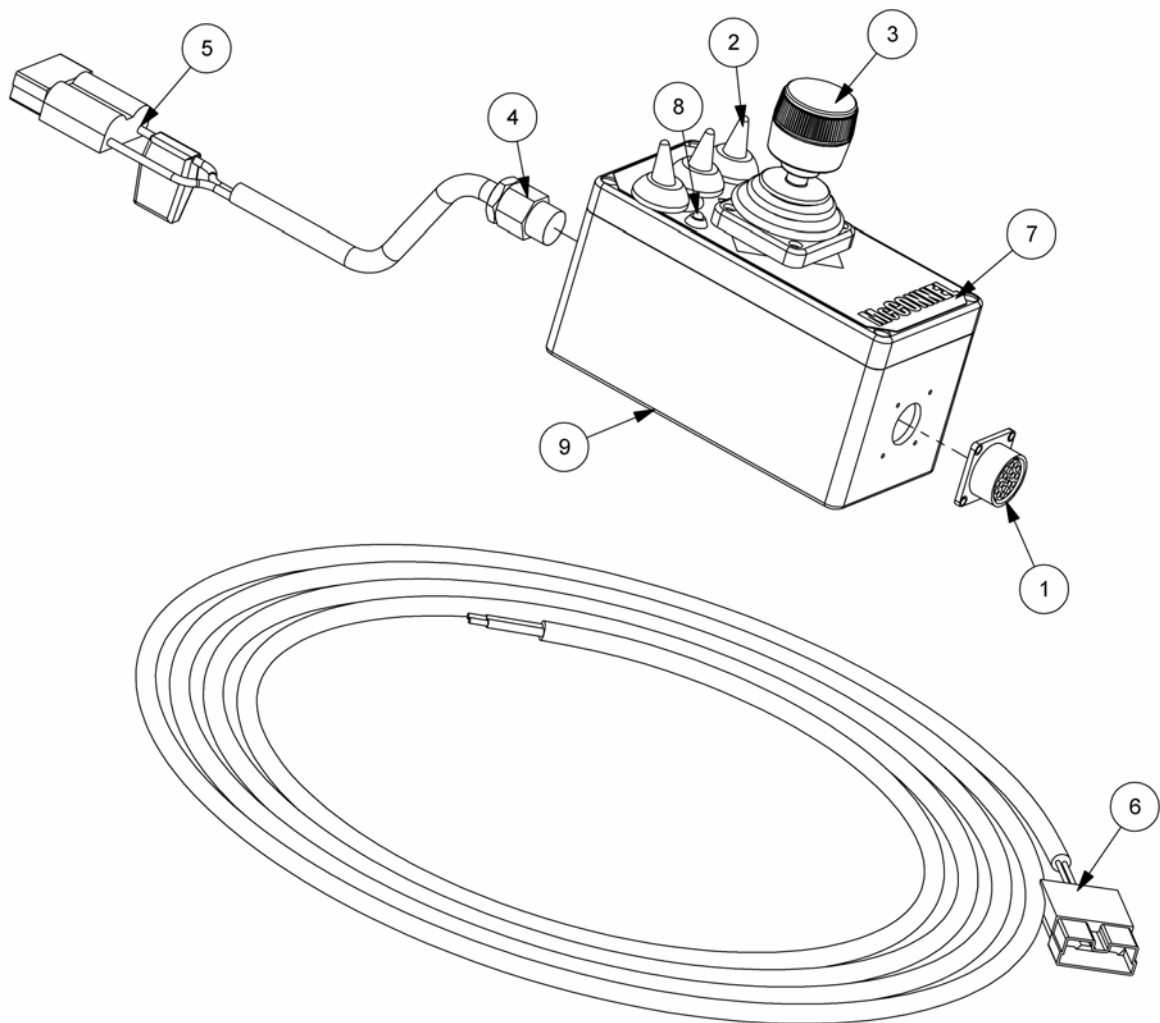

CONTROL BOX - Mini Single Lever

REF.	QTY.	PART No.	DESCRIPTION
		8402390	CONTROL BOX - B/B 2 Switch
		8402391	CONTROL BOX - Prop. B/B 2 Switch
		8402392	CONTROL BOX - Prop. B/B 3 Switch
		8402393	CONTROL BOX - Prop. 3 Switch
1	1	8402189	PANEL MTG SHELL
2	3*	8402024	SWITCH COVER
3	1	8402246	JOYSTICK (4 AXIS)
4	1	8402149	GLAND - PLASTIC
5	1	43022.47	CONNECTOR
6	1	8402237	LOOM POWER SUPPLY
7	1	1290494	DECAL - SWITCH BOX
8	1	41845.41	LED
9	1	8402349	CONTROL BOX
10	1	43034.02	BLADE FUSE - 20 amp

* Control Boxes 8402390 & 8402391 use 2 off only

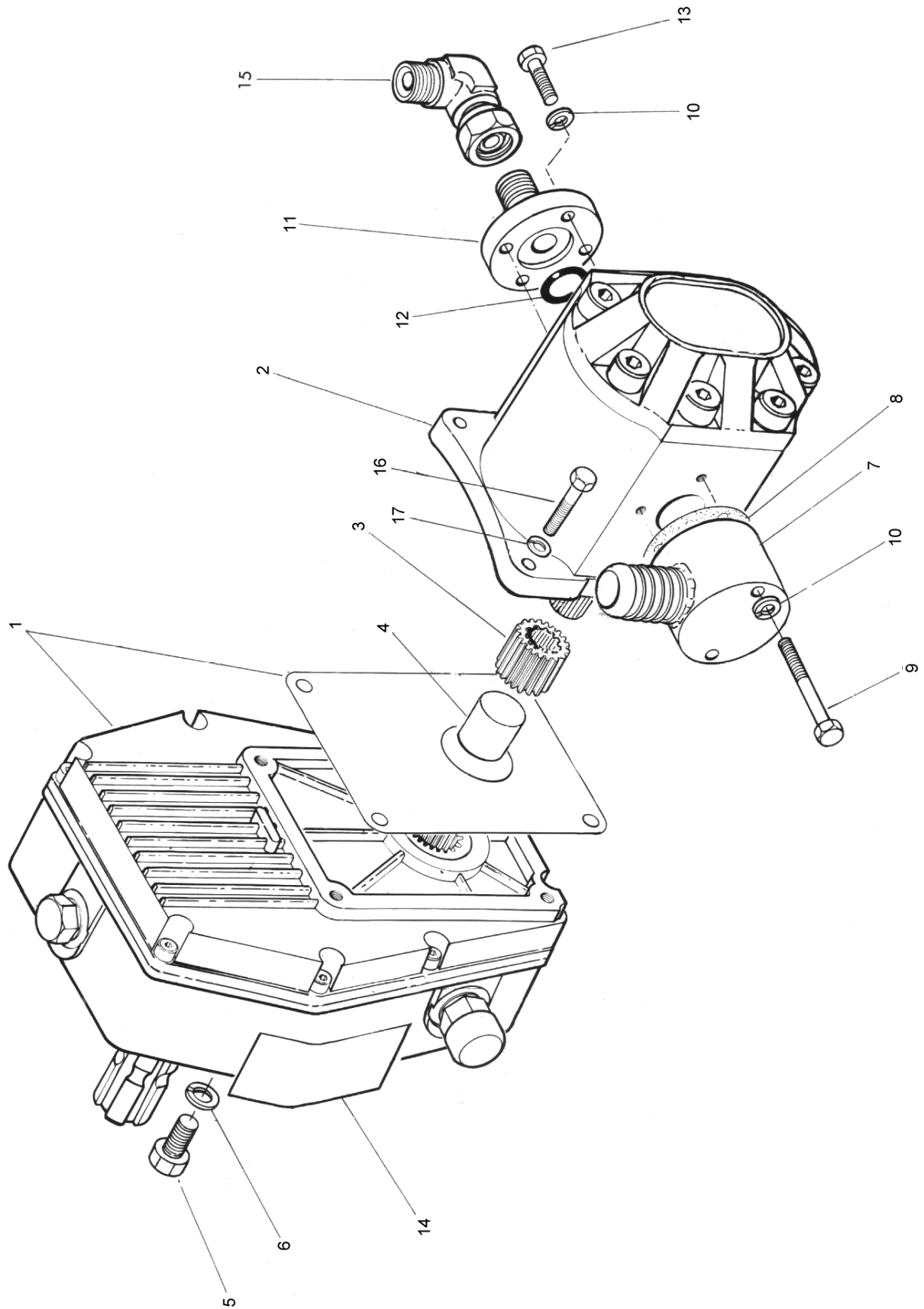

PUMP & GEARBOX – Si Models

REF.	QTY.	PART No.	DESCRIPTION
			PUMP & GEARBOX ASSEMBLY - Si Models
1	1	8013443	Gearbox Assembly
2	1	8201463	Pump
3	1	8013097	Coupling
4	1	42415.02	Spacer
5	4	9313046	Setscrew
6	4	9100206	Spring Washer
7	1	8012022/B	Suction Connection
8	1	8013023	Gasket
9	2	9213144	Bolt
10	6	9100204	Spring washer
11	1	8013083	Pressure Connection
12	1	8600119	'O' Ring
13	4	9313054	Setscrew
14	1	1290030	Sticker
15	1	8581338	Elbow - Swivel
16	4	9213095	Bolt
17	4	9100205	Spring Washer
		8699231	PUMP SEAL KIT

PUMP & GEARBOX – Ti Models

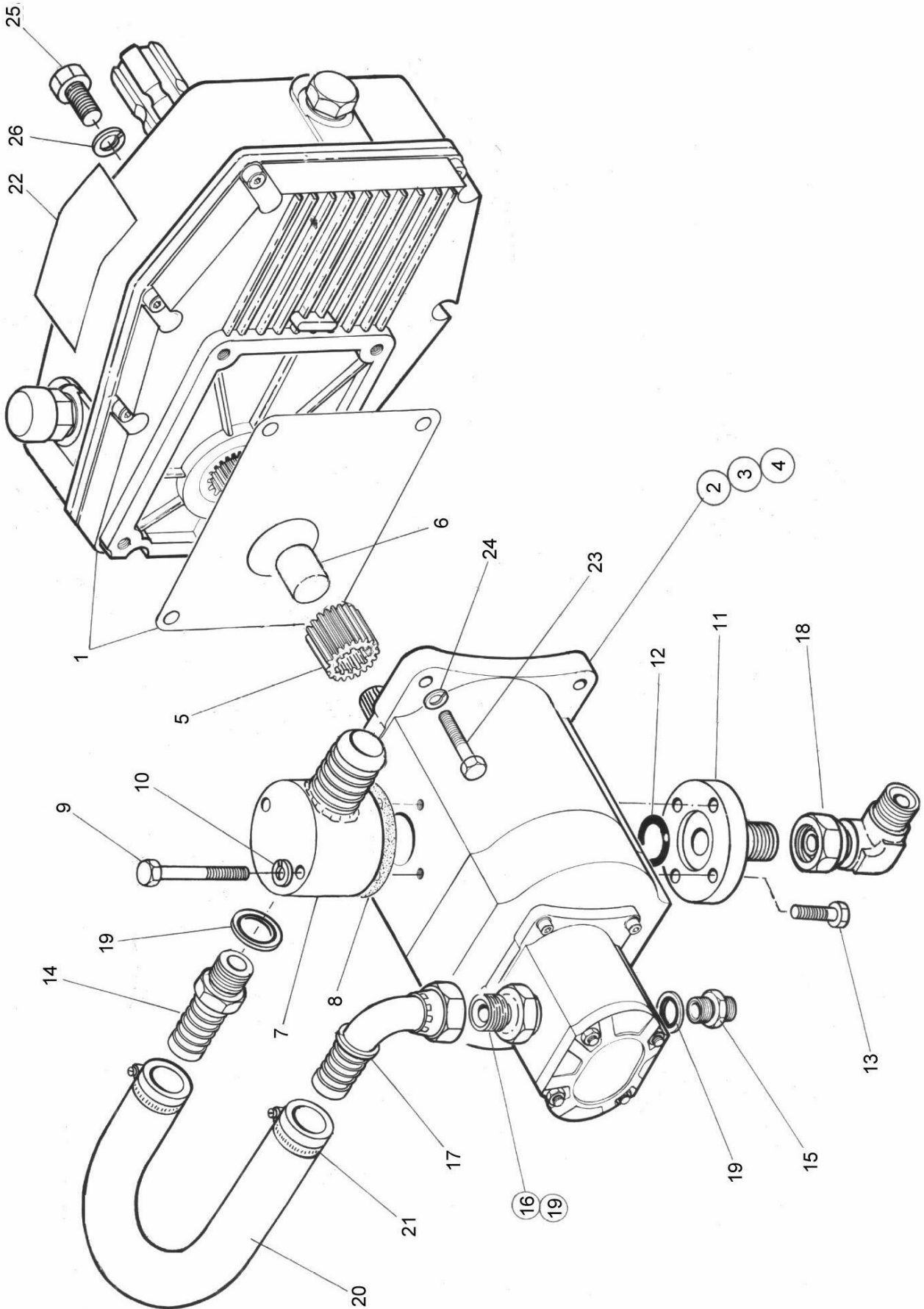



PUMP & GEARBOX – Ti Models

REF.	QTY.	PART No.	DESCRIPTION
		41317.01	TI PUMP & GEARBOX ASSEMBLY - L/H Build
		41317.06	TI PUMP & GEARBOX ASSEMBLY - R/H Build
1	1	 8013443	Gearbox Assembly
2	1	8201693	Tandem Pump for Front Mount Models (ACW)
	1	8201466	Tandem Pump for Std. Models - <i>comprising of:</i>
3	1	8201684	Large Pump
4	1	8201677	Small Pump
5	1	8013097	Coupling
6	1	42415.02	Spacer
7	1	8013082	Suction Connection
8	1	8013023	Gasket
9	2	9213144	Bolt
10	2	9100204	Spring Washer
11	1	8013083	Pressure Connection
12	1	8600119	'O' Ring
13	4	9300147	Setscrew
14	1	8002059	Adaptor - low pressure
15	1	6000112	Adaptor
16	1	G3812120	Adaptor
17	1	8581173	Elbow - <i>low pressure</i>
18	1	8581338	Elbow - <i>swivel</i>
19	2	8650104	Bonded Seal
20	1	8501099	Hose - 5/8" bore x 13" long
21	2	0904204	Hose Clips
22	1	1290030	Gearbox Label
23	4	9213095	Bolt
24	4	9100205	Spring Washer
25	4	9313046	Setscrew
26	4	9100206	Spring Washer
		8699231	PUMP SEAL KIT

GEARBOX ASSEMBLY

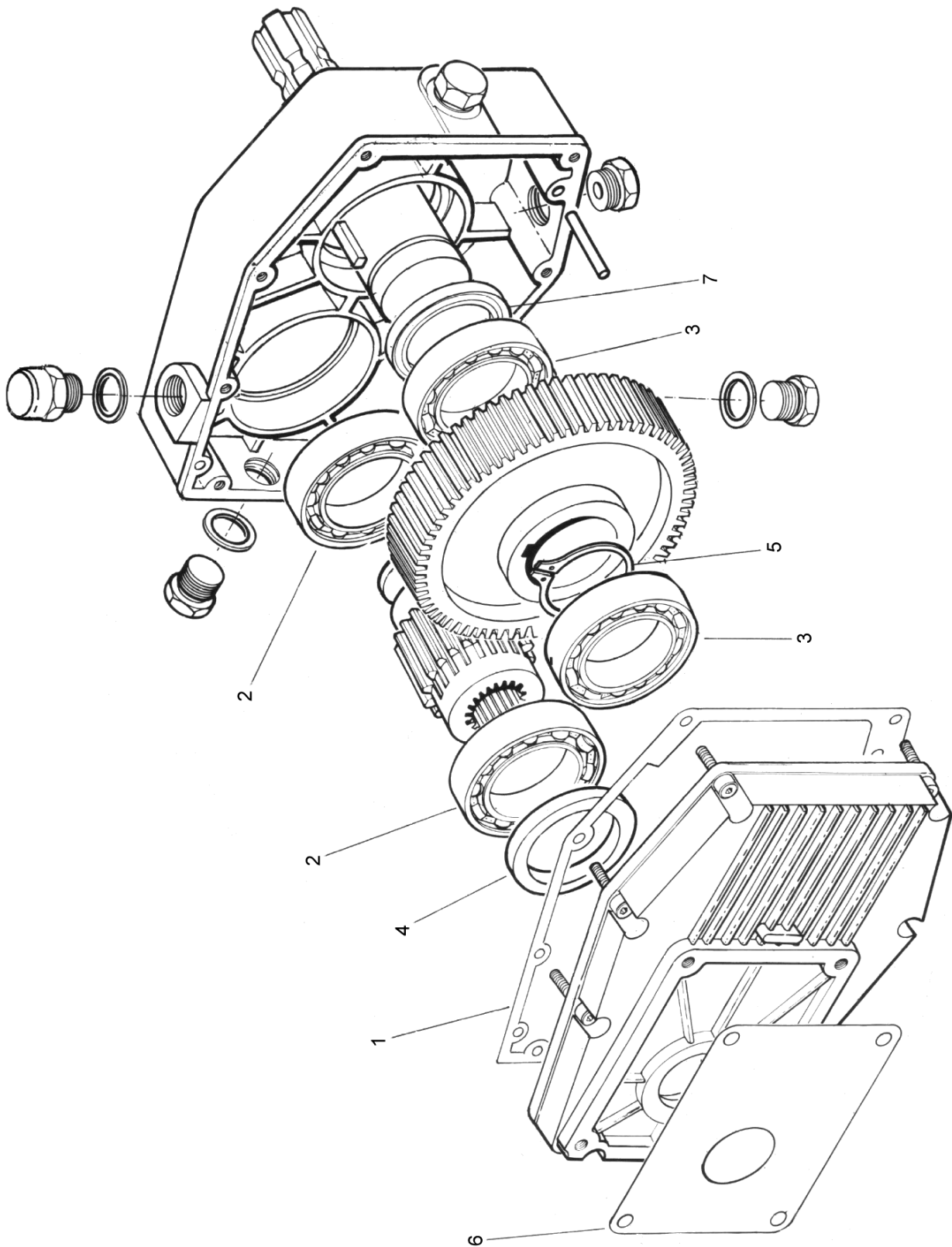

**GEARBOX ASSEMBLY**

REF.	QTY.	PART No.	DESCRIPTION
		8013443	GEARBOX ASSEMBLY
1	1	8013087	Gearbox Casing Sealing Gasket
2	2	0600047	Bearing
3	2	0600048	Bearing
4	1	8629139	Seal
5	1	0401250	External Circlip
6	1	9013056	Pump Face Gasket
7	1	8629134	Seal

HYDRAULIC TANK ASSEMBLY

MODULES:

7490779 – L/H Build

7490780 – R/H Build

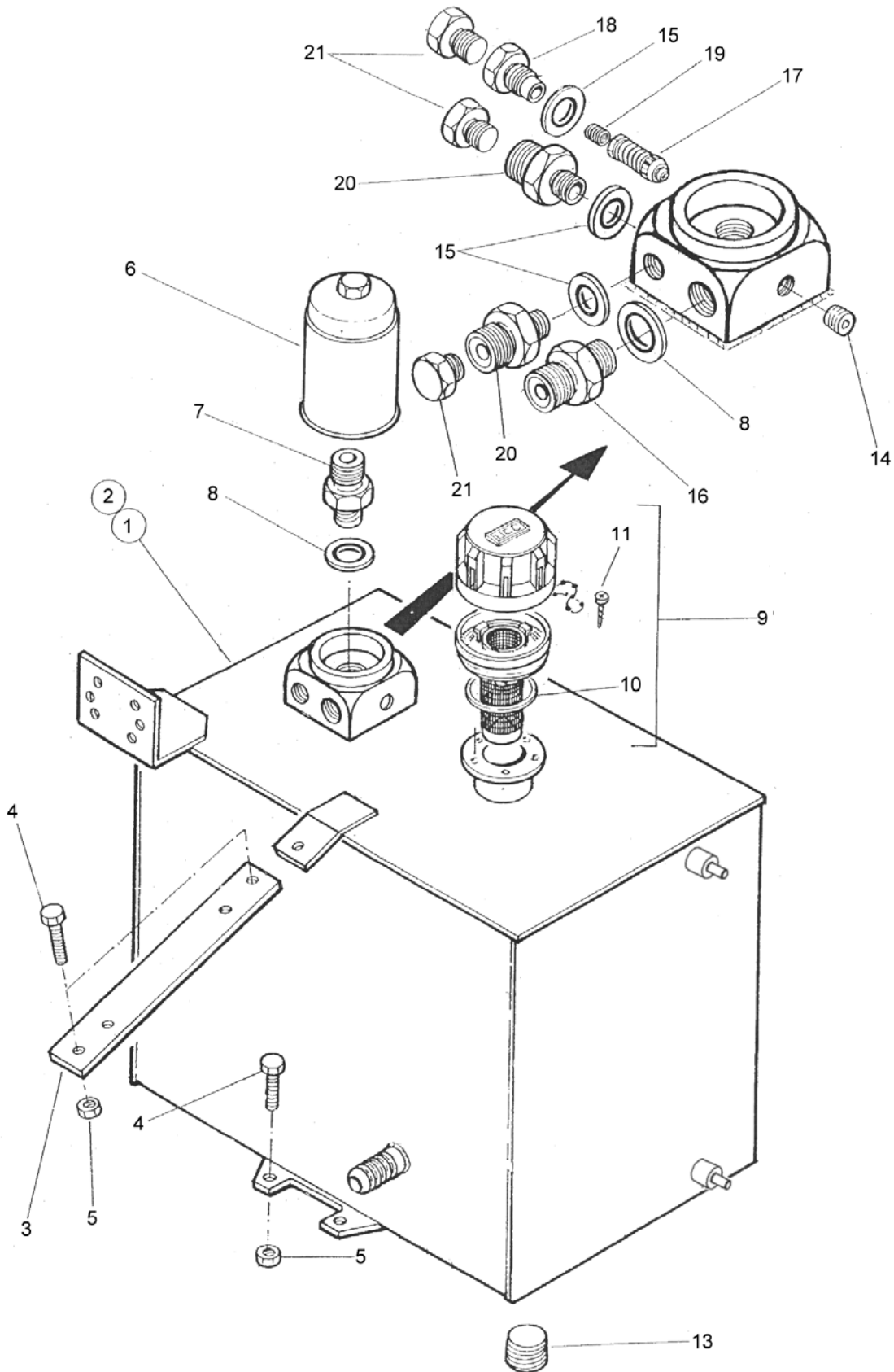



HYDRAULIC TANK ASSEMBLY

REF.	QTY.	PART No.	DESCRIPTION
		7490779	HYDRAULIC OIL TANK ASSEMBLY - L/H Build
		7490780	HYDRAULIC OIL TANK ASSEMBLY - R/H Build
1	1	41196.05	Tank - L/H (<i>Right Hand on Front Mounted Models</i>)
2	1	41196.06	Tank - R/H (<i>Left Hand on Front Mounted Models</i>)
3	1	41204.01	Tank Strap
4	4	9313065	Setscrew
5	4	9143005	Self Locking Nut
6	1	8401045	Filter
7	1	8581174	Adaptor
8	2	8650104	Bonded Seal
9	1	8401014	Filler/Breather Assembly - <i>comprising of:</i>
10	1	8401017	Gasket
11	6	0300082	Screw - Self Tapping
12	2	9100205	Spring Washer
13	1	8581203	Drain plug
14	1	8582042	Plug
15	3	8650103	Bonded Seal
16	1	G381.2120	Adaptor
17	1	8130030	Relief Valve
18	1	8130031	Relief Valve Housing
19	1	8116011	Spring
20	2	8581175	Adaptor
21	3	8003001	Blanking Plug - <i>Ti only</i>

} *Si only*

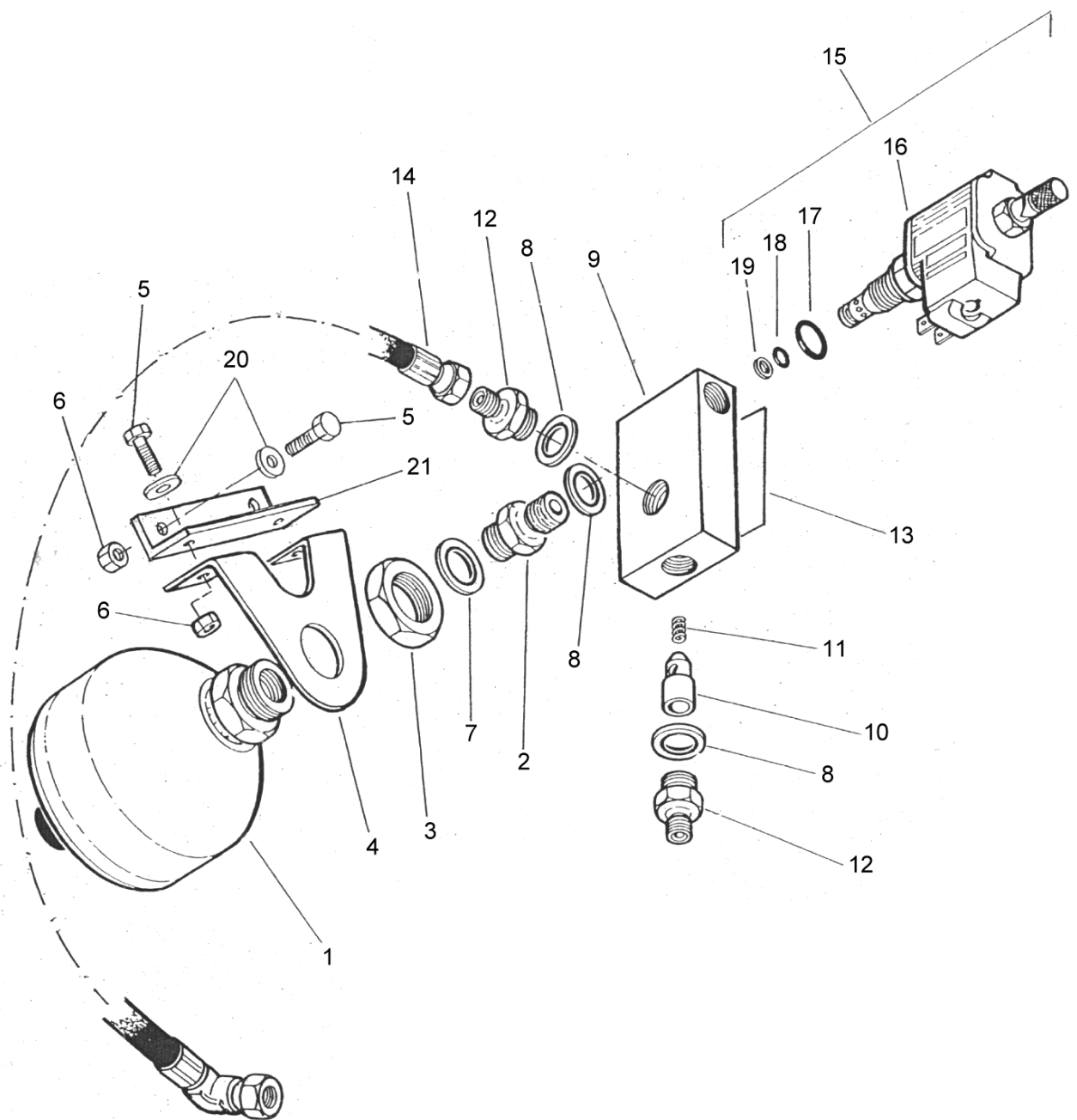

LIFT FLOAT KIT – Quick Response

REF.	QTY.	PART No.	DESCRIPTION
		8126291	LIFT FLOAT KIT - Quick Response
1	1	8126042	Accumulator
2	1	G2410380	Adaptor
3	1	8126035	Bulkhead Nut
4	1	8126286	Bracket
5	4	9313054	Setscrew
6	4	9143004	Self Locking Nut
7	1	8650322	Bonded Seal
8	3	8650103	Bonded Seal
9	1	8126287	Control Block
10	1	8126037	Response Piston
11	1	8116011	Spring
12	2	8581115	Adaptor
13	1	1290061	Operating Sticker
14	1	8535012	Hose 1/4" BSP x 12" Long SF/90F
15	1	8130183	Poppet Valve <i>inc:</i>
16	1	8130184	Coil
17	1	8700017	'O' Ring
18	1	8700511	'O' Ring
19	1	8709511	Anti Extrusion Ring
20	2	9100104	Plain Washer
21	1	8126306	Mounting Bracket

LIFT RAM ASSEMBLY

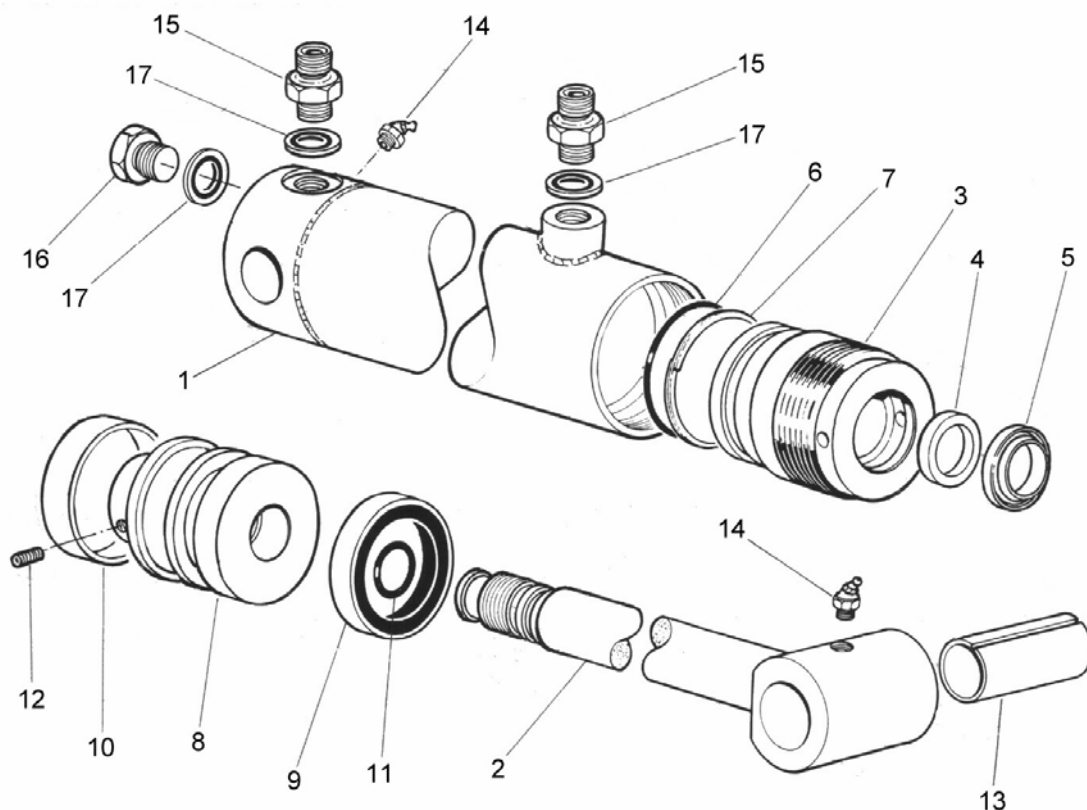

REF.	QTY.	PART No.	DESCRIPTION
		41014.03	LIFT RAM ASSEMBLY
1	1	41034.01	Ram Barrel
2	1	41035.01	Piston Rod
3	1	7120384	Gland Housing
4	1	8629164	Gland Seal
5	1	8629147	Piston Rod Wiper Seal
6	1	8600429	'O' Ring
7	1	8609429	Anti Extrusion Ring
8	1	7120383	Piston
9	1	8629189	Piston Seal
10	1	8629190	Guide Ring
11	1	8600403	'O' Ring
12	1	9363023	Grub Screw
13	1	7105050	Bush
14	2	0901124	Greaser
15	2	03.028.08	Restrictor Union
16	1	8003001	Plug
17	3	8650103	Bonded Seal

8699228 SEAL KIT

REACH RAM ASSEMBLY

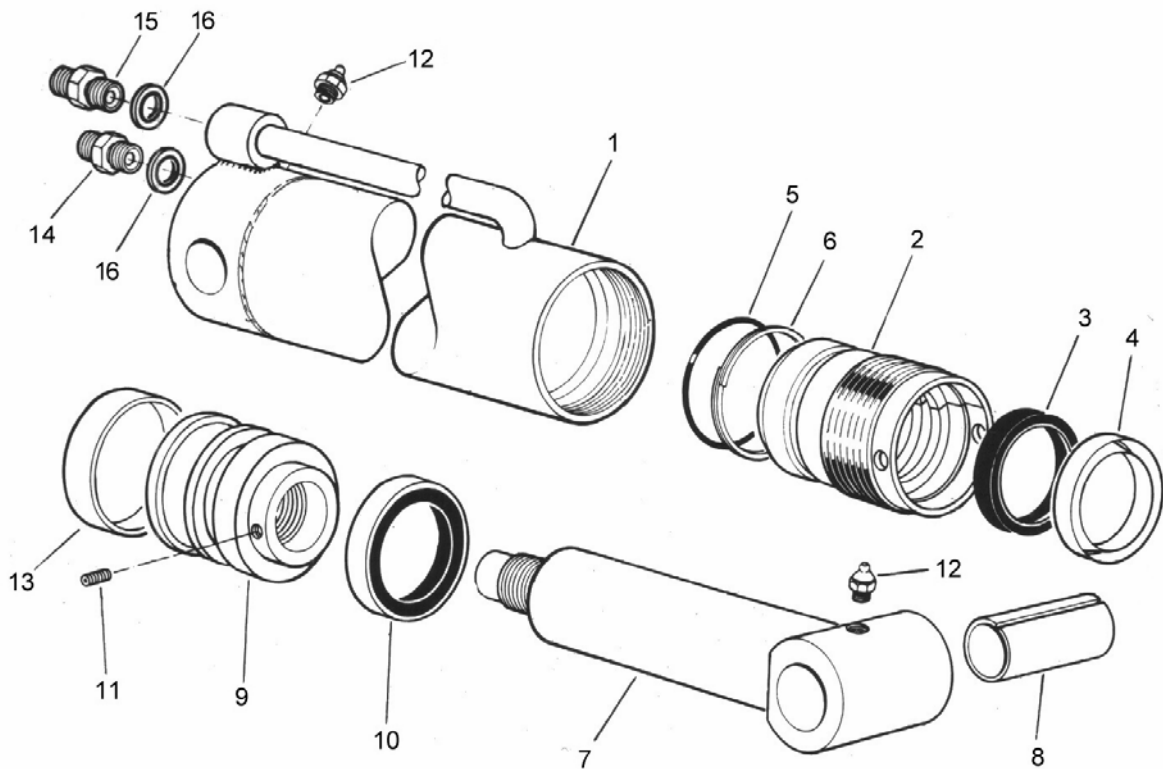

REF.	QTY.	PART No.	DESCRIPTION
		41015.03	REACH RAM ASSEMBLY
1	1	41036.01	Ram Barrel
2	1	1186512	Gland Housing
3	1	8629164	Gland Seal
4	1	8629147	Piston Rod Wiper Seal
5	1	8600306	'O' Ring
6	1	8609306	Anti Extrusion Ring
7	1	41037.01	Piston Rod
8	1	7105050	Bush
9	1	7120368	Piston
10	1	8629156	Piston Seal
11	1	9363023	Grub Screw - Socket Headed
12	2	0901121	Greaser - Straight
13	1	8627157	Guide Ring
14	1	8130046	Restrictor Union
15	1	8130066	Restrictor Union
16	2	8650103	Bonded seal

8699217 SEAL KIT

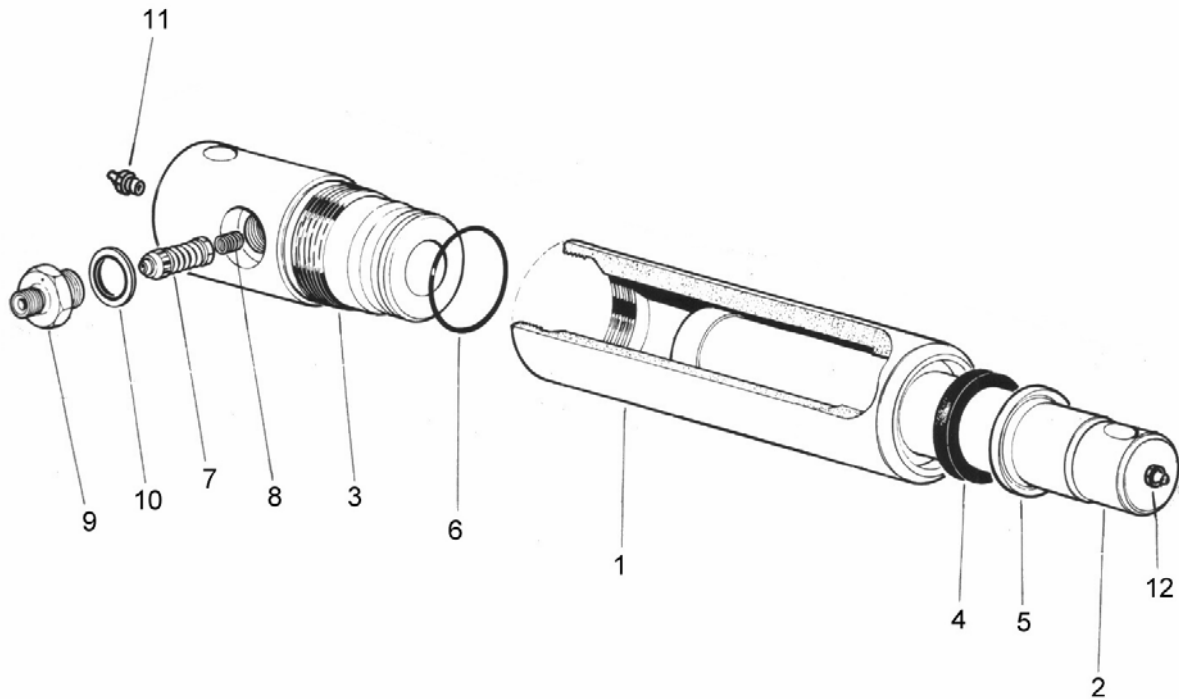
BREAKAWAY RAM ASSEMBLY

REF.	QTY.	PART No.	DESCRIPTION
		41322.02	BREAKAWAY RAM ASSEMBLY
1	1	7191308	Ram Barrel
2	1	7191051	Rod
3	1	7191299	Ram Base
4	1	8629158	Rod Seal
5	1	8529152	Wiper Seal
6	1	8600302	'O' Ring
7	1	8130189	Relief Valve
8	1	8116011	Spring
9	1	8130083	Relief Valve Body
10	1	8650104	Bonded Seal
11	2	0901121	Greaser

ANGLING RAM ASSEMBLY

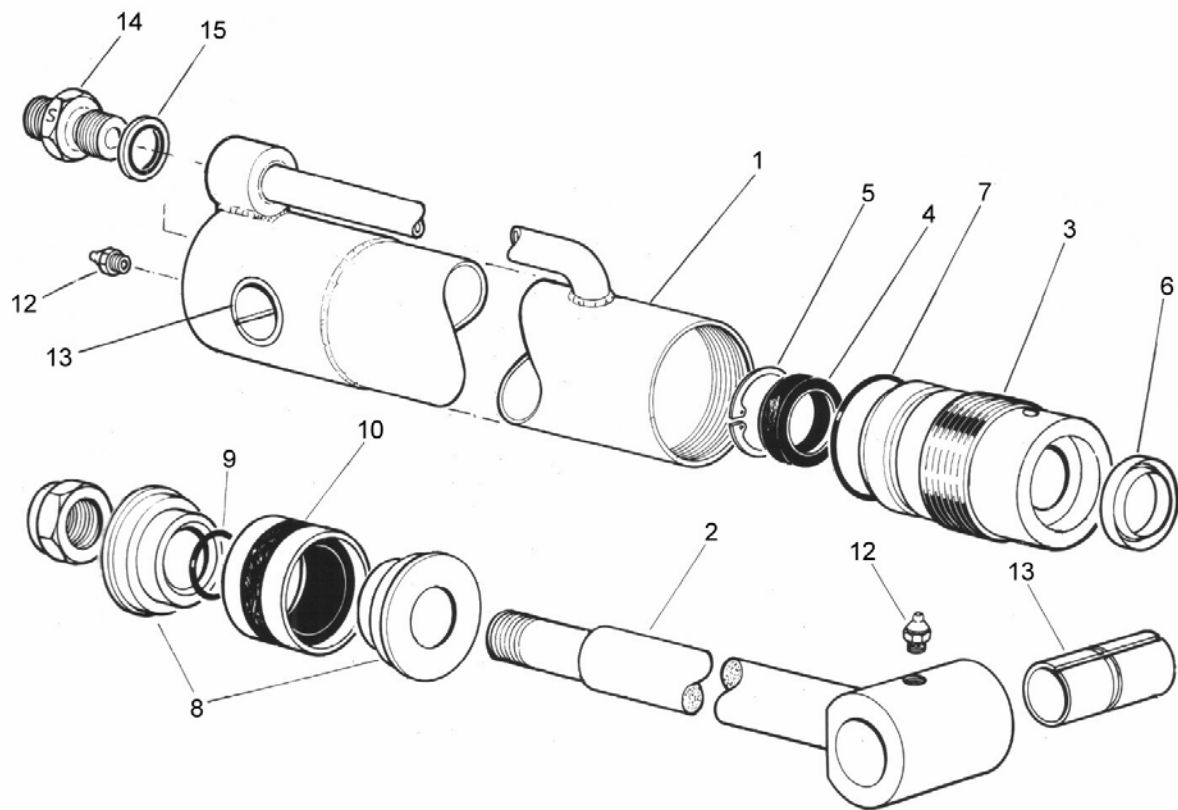

REF.	QTY.	PART No.	DESCRIPTION
		7191072	ANGLING RAM ASSEMBLY
			Basic Ram comprising of:
1	1	7191295	Cylinder
2	1	1090031	Piston Rod
3	1	1090273	Gland Nut
4	1	8629162	Gland Seal
5	1	0416234	Circlip
6	1	8629161	Wiper Ring
7	1	8600123	'O' Ring
8	2	1090034	Piston
9	1	8600112	'O' Ring
10	1	8629160	Piston seal
11	1	0141007	Self-Locking Nut
12	1	0901121	Greaser
13	2	1090005	Bush
14	2	8130037	Restrictor Union 'S'
15	2	8650102	Bonded Seal

8699202 SEAL KIT

Assembly Note: Assemble locknut onto rod using 'Permabond A113' or similar medium strength thread locking compound.

REAR COVERS ASSEMBLY

MODULES:

7490775 – L/H BUILD

7490776 – R/H BUILD

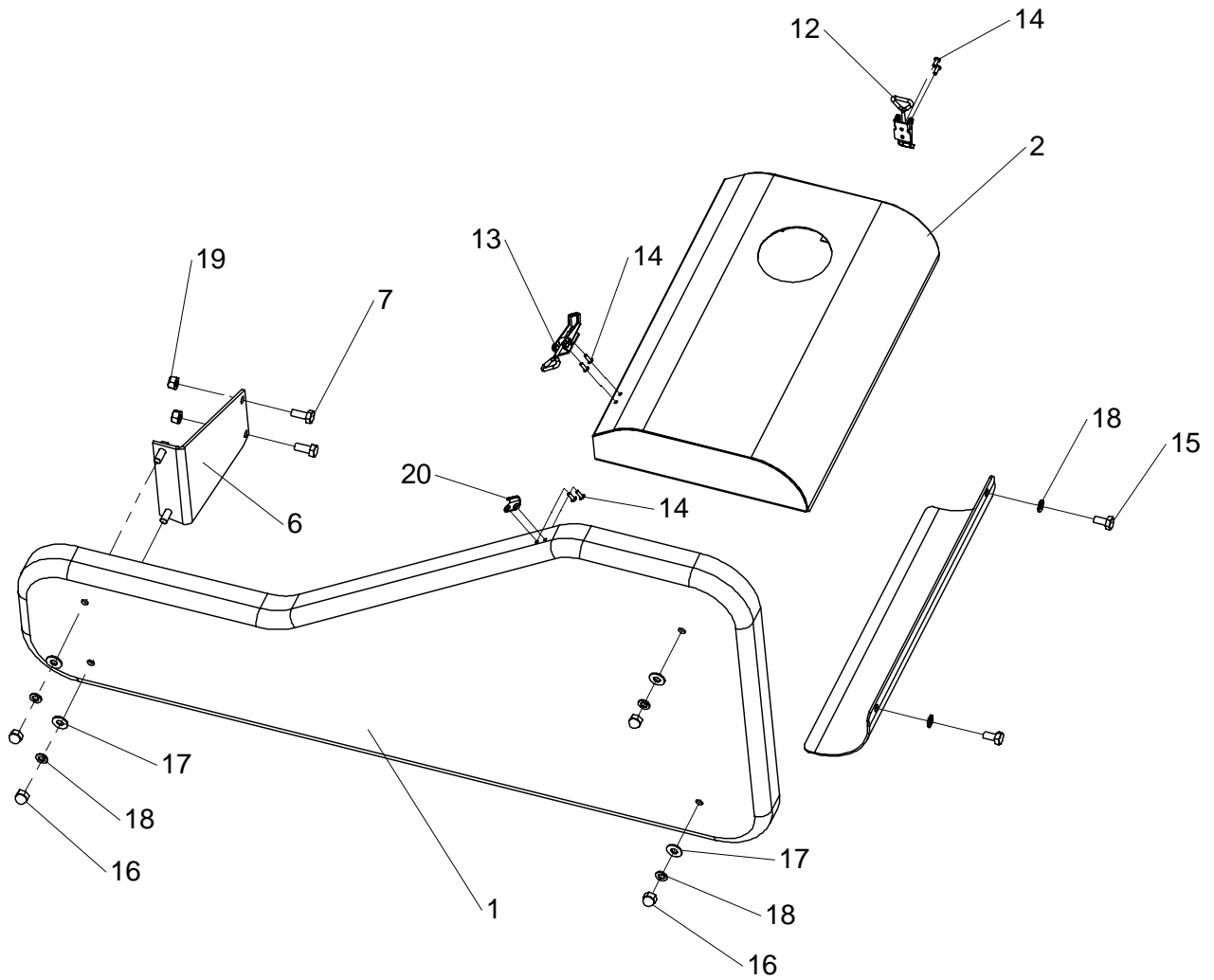

**REAR COVERS ASSEMBLY**

REF.	QTY.	PART No.	DESCRIPTION
		7490775	REAR COVERS ASSEMBLY - L/H BUILD
		7490776	REAR COVERS ASSEMBLY - R/H BUILD
1	1	45629.01	Rear Cover - L/H
	1	45629.02	Rear Cover - R/H
2	1	45633.01	Tank Cover - L/H
	1	45633.02	Tank Cover - R/H
3	1	45636.02	Support Bracket - L/H
	1	45636.04	Support Bracket - R/H
4	1	45638.01	Fairing - Tank
5	2	43449.02	Overcentre Fastener
6	6	1069088	Pop Rivet
7	2	9313055	Setscrew
8	2	9313045	Setscrew
9	4	9100025	Dome Nut
10	4	9100105	Flat washer
11	6	9100205	Spring Washer
12	2	9143005	Self Locking Nut
13	1	46007.01	Hook - Overcentre Fastener

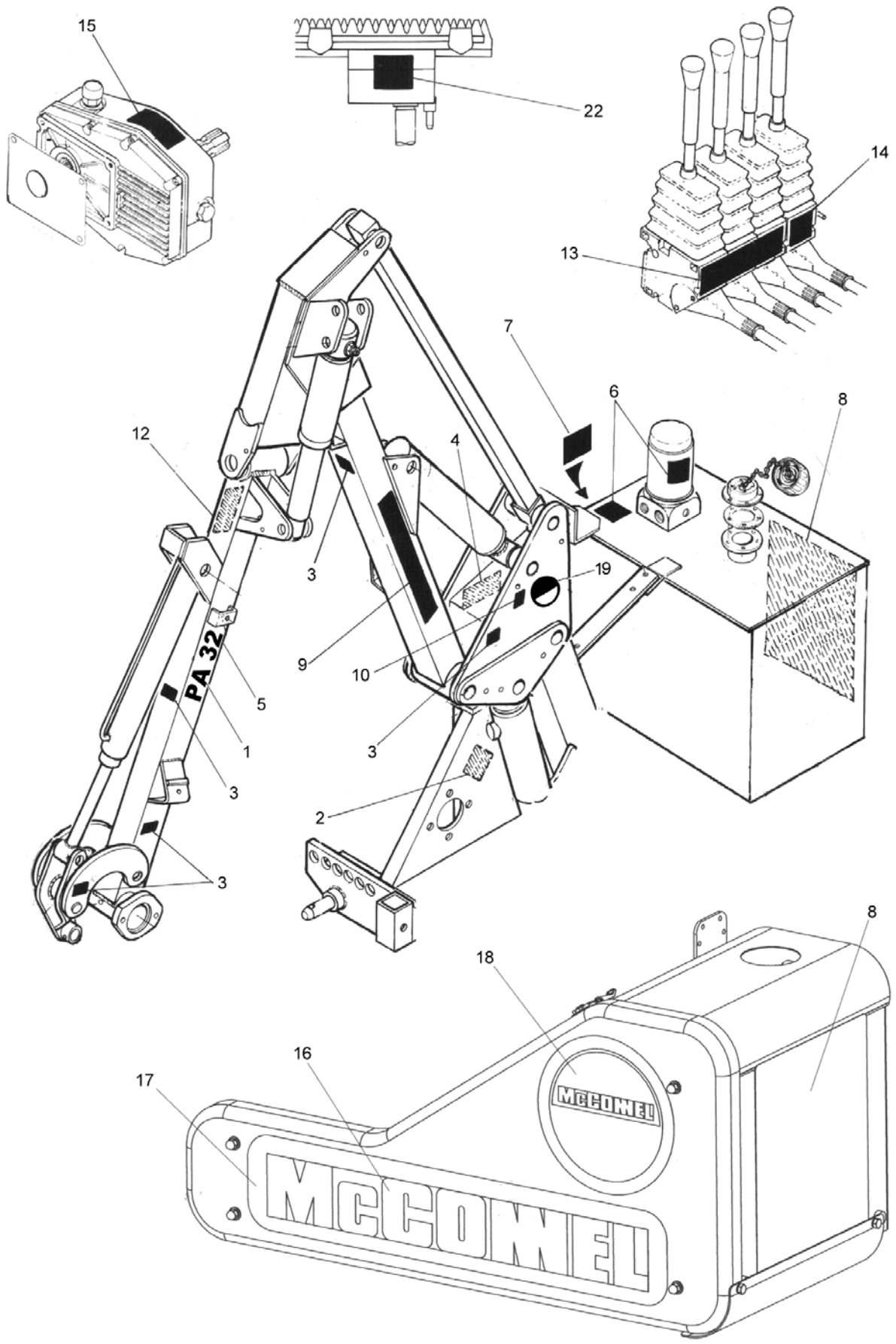



MACHINE DECALS

REF.	QTY.	PART No.	DESCRIPTION
			MACHINE DECALS
1	2	1290453	PA - Black
2	1	7105130	Read Instruction Manual
3	5	02962764	Pinch Point
4	1	7135295	Tighten Check Chains
5	2	1290552	32 - Black
6	1	1290023	Oil Filter Instruction
7	1	00756494	PTO Fitting/Warning
8	1	1290391	General Safety
9	2	1290255	McConnel
10	1	1290074	Sling Here
11	1	1290352	General Warning (<i>Supplied loose for cab location</i>)
12	1	1290403	Breakaway Warning
13	1	1290368	Arm Controls
14	1	1290338	Rotor Controls/Cutterbar ON/OFF - <i>Ti only</i>
15	1	1290030	Gearbox Oil Instructions
16	1	1290527	McConnel - Large Black
17	1	1290553	Backing Panel - Yellow
18	1	1290554	McConnel Roundel - Yellow
19	1	1290296	Logo
20	1	1335246	Serial No. Plate
21	4	7103230	Pop Rivets
22	1	1290078	Warning - Danger to fingers

Modules:

7150770 – L/H Build

7150771 – R/H Build

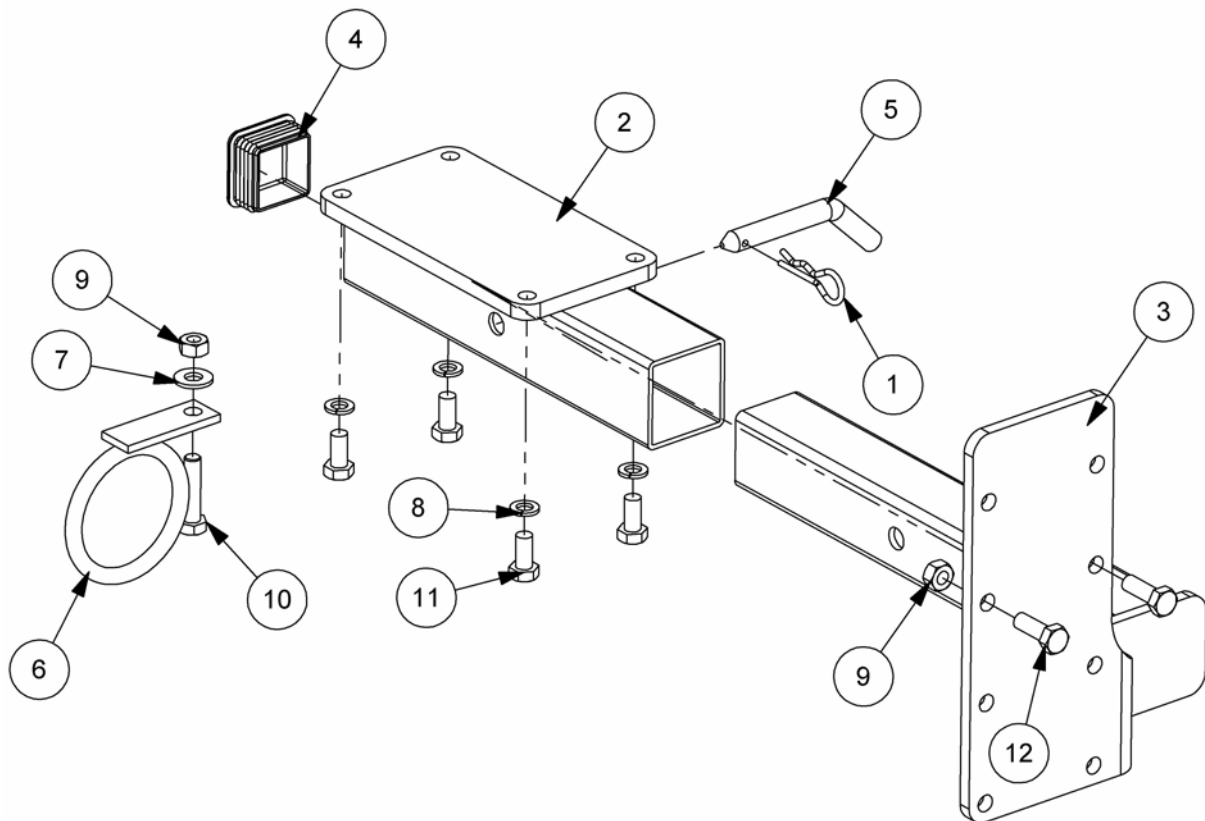
Illustrated in Left Hand Build

REF.	QTY.	PART No.	DESCRIPTION
		7150770	DEBRIS BLOWER MOUNTING KIT - L/H Machines
		7150771	DEBRIS BLOWER MOUNTING KIT - R/H Machines
1	1	0431105	SPRING COTTER
2	1	43492.01	BLOWER BRACKET
3	1	43492.05	BLOWER BRACKET - L/H Build
	1	43492.06	BLOWER BRACKET - R/H Build
4	1	7191108	PLASTIC PLUG
5	1	7192023	LEG PIN
6	1	7319282	HOSE RING
7	1	9100106	FLAT WASHER
8	4	9100206	SPRING WASHER
9	3	9143006	SELF-LOCKING NUT
10	1	9213106	BOLT
11	4	9313056	SETSCREW
12	2	9313076	SETSCREW

Suitable for the following machines:

PA32, PA41, PA45, PA47 Mk1*, PA47 Mk2, PA48, PA50Mk1*, PA50 Mk2, PA55/60
(* without lightbars)*

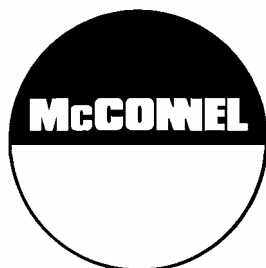

McConnel Limited, Temeside Works, Ludlow, Shropshire SY8 1JL. England.
Telephone: 01584 873131. Facsimile: 01584 876463. www.mcconnel.com