

Publication 589
March 2009
Part No. 41571.89
Revision: 14.08.09

DISCAERATOR

Primary Cultivator



Parts Manual

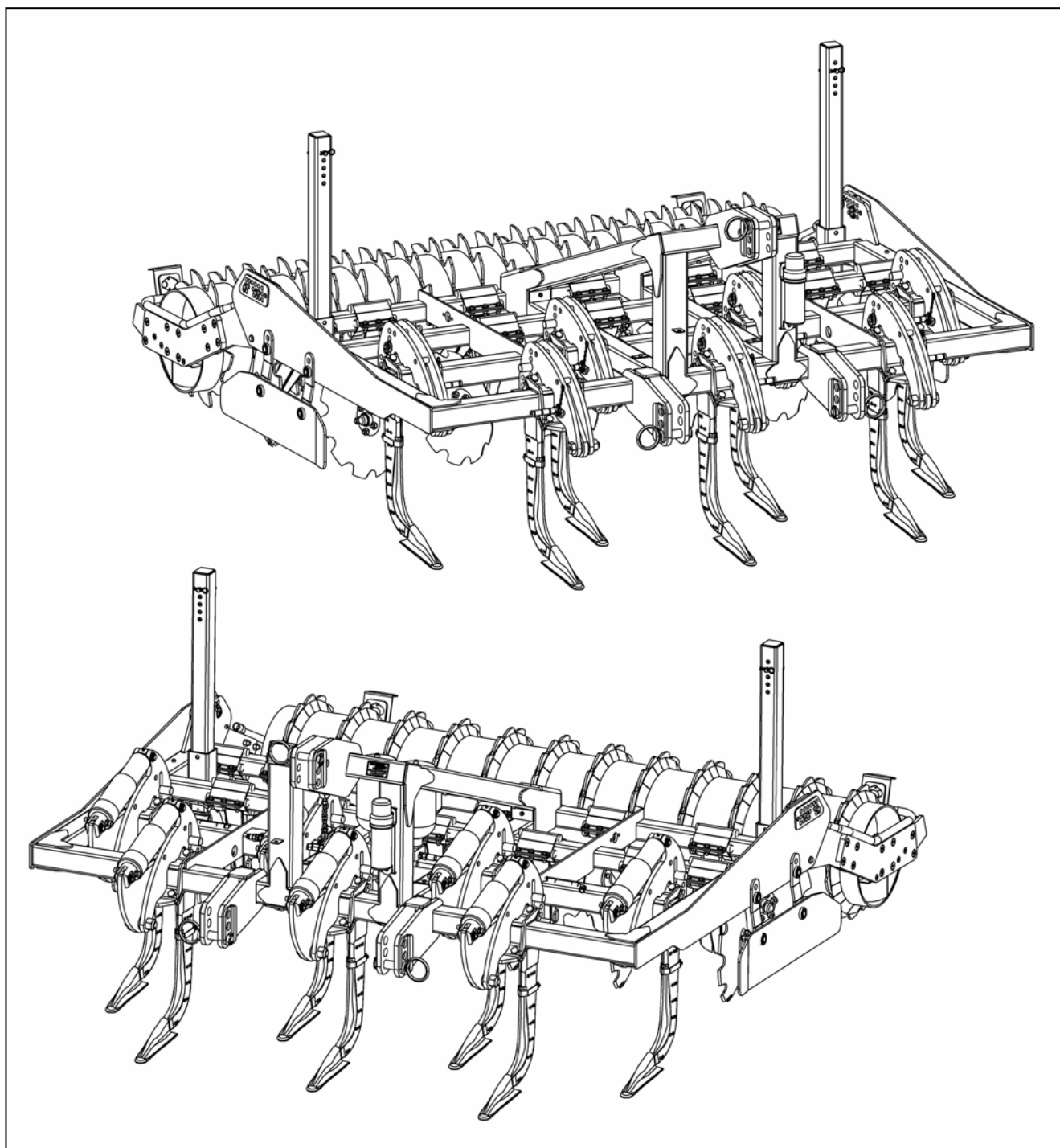



For best performance ...

USE ONLY GENUINE McCONEL SERVICE PARTS

*To be assured of the latest design improvements purchase your
'Genuine Replacements' from the 'Original Equipment Manufacturer'*

McCONEL LIMITED

Through your local Dealer or Stockist

Always quote:

- ***Machine Type***
- ***Serial Number***
- ***Part Number***

*Design improvements may alter some of the parts listed in this manual –
the latest parts will always be supplied when it is interchangeable with an earlier one.*

CONTENTS

Main Frame Assembly	1
Single Front Disc Assembly (<i>Outer</i>)	2
Single Front Disc Assembly (<i>Inner</i>)	3
Single Rear Disc Assembly	4
Double Rear Disc Assembly	5
Replaceable Hub Components	6
Breakback Leg Assemblies (<i>Mechanical</i>)	8
Breakback Leg Assembly (<i>Hydraulic</i>)	10
Shank Assembly	12
Hydraulic Ram Assembly	14
Hydraulic Installation (<i>5 Leg models</i>)	16
Hydraulic Installation (<i>7 Leg models</i>)	18
Packer Roller Assembly (<i>600mm</i>)	20
Ridge Packer Roller Assembly (<i>600mm</i>)	22
Ridge Packer Roller Assembly (<i>800mm</i>)	24
Guttler Roller Assembly	26
Rear Lighting Kit	28
Decal Kit	29

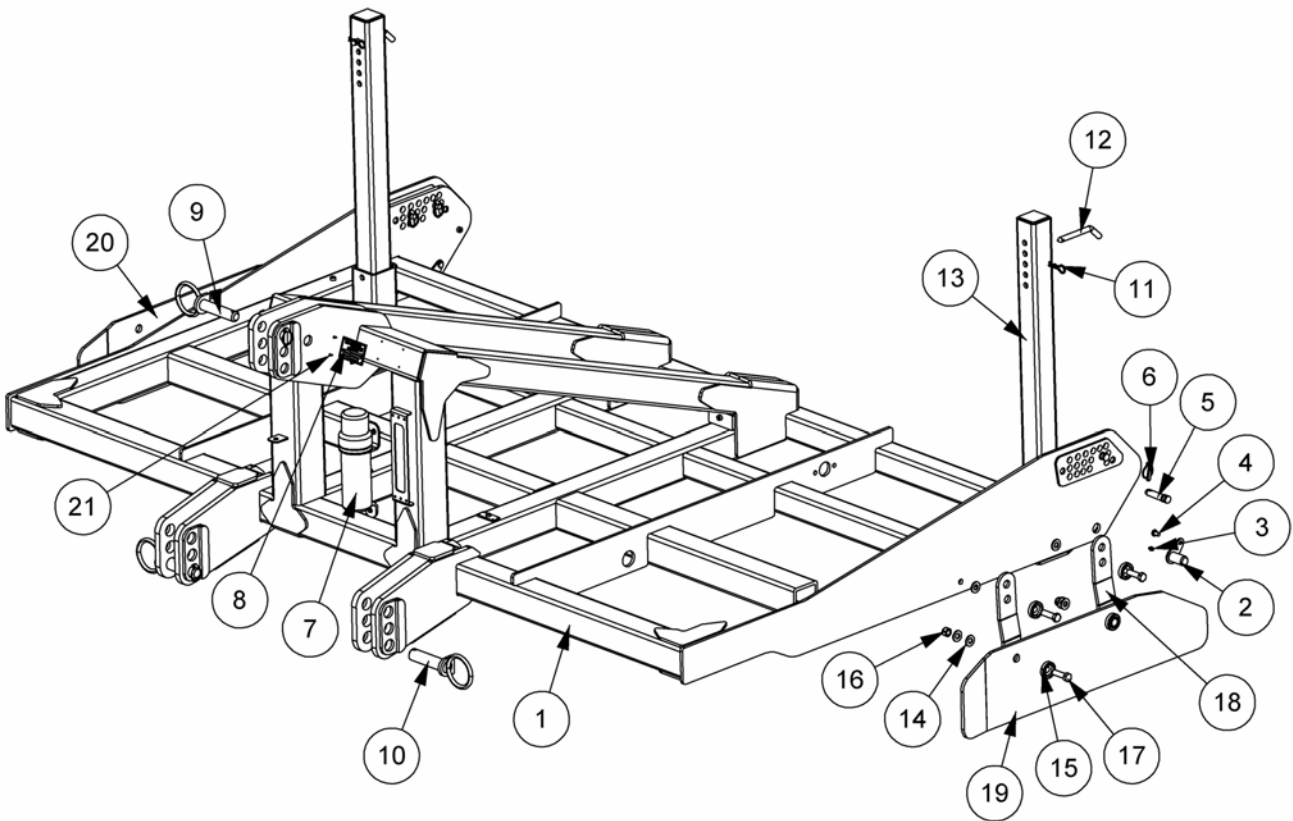

REF.	QTY.	PART No.	DESCRIPTION
		1068706	MAIN FRAME ASSEMBLY
1	1	22521.07	DISCAERATOR FRAME
2	2	42684.16	PIN
3	2	0901121	GREASE NIPPLE
4	2	9313035	SETSCREW
5	4	41267.08	LINK PIN
6	7	0431217	LINCH PIN
7	1	46505.02	MANUAL HOLDER
8	1	1335246	SERIAL No. PLATE
9	1	22617.01	TOP LINK PIN
10	2	22617.02	BOTTOM LINK PIN
11	2	0431105	SPRING COTTER
12	2	43327.02	LEG PIN
13	2	22537.08	STAND ASSY
14	16	0100106	WASHER
15	8	22537.44	COLLAR
16	8	9163007	NYLOC NUT
17	8	9213117	BOLT
18	4	22537.42	SIDE SKIRT HINGE PLATE
19	1	22537.40	RH SIDE SKIRT
20	1	22537.43	LH SKIRT PLATE
21	4	7103230	POP RIVET

SINGLE FRONT DISC ASSEMBLY (OUTER)

McCONEL

Module(s): 22612.02

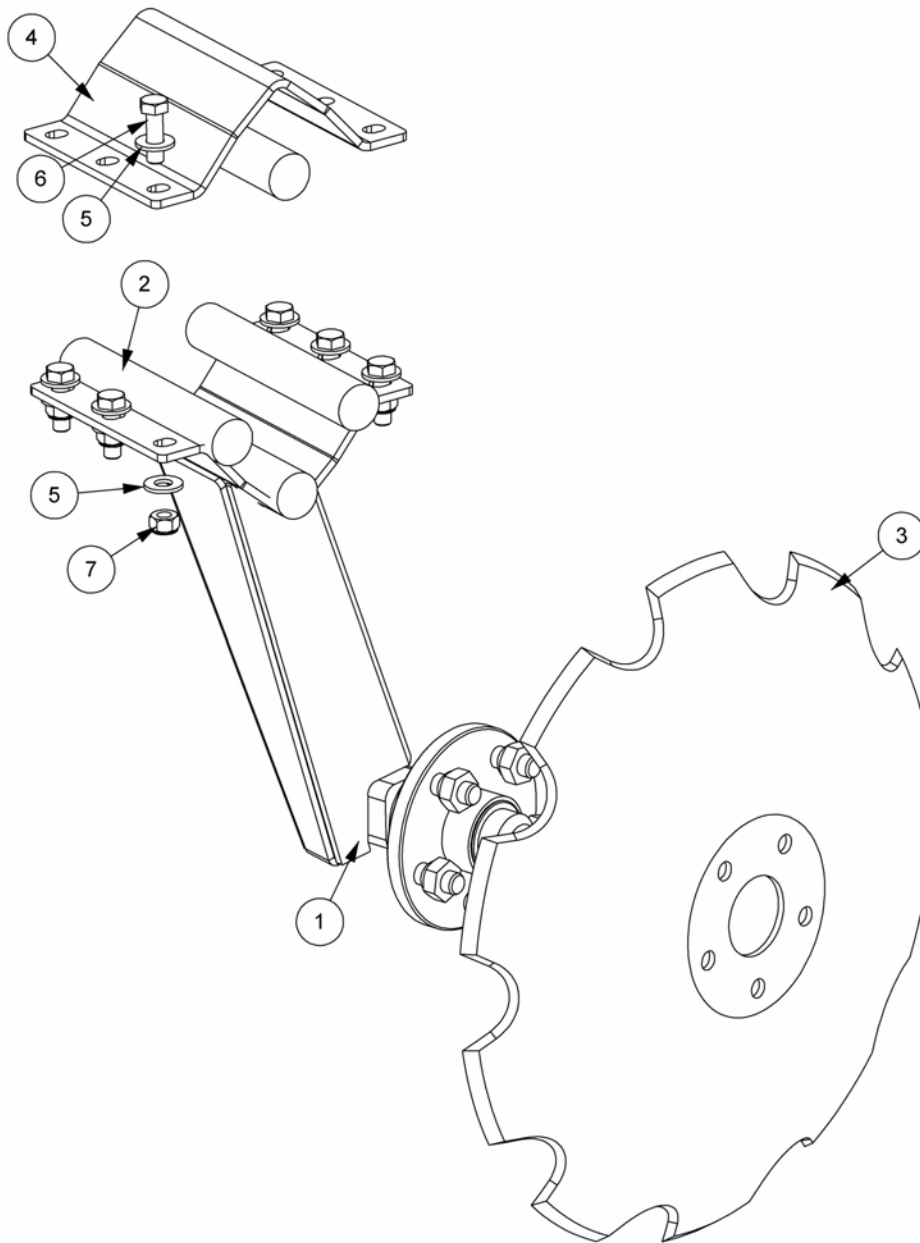

REF.	QTY.	PART No.	DESCRIPTION
		22612.02	SINGLE OUTER FRONT DISC ASSEMBLY
1	1	22612.11	FRONT LEG & HUB (SINGLE OUTER)
2	4	22546.39	RUBBER SHOCK ABSORBER
3	1	22546.11	CONCAVE SERRATED DISC
4	1	22546.60	DISC CLAMP
5	12	9100106	FLAT WASHER
6	6	9213086	BOLT
7	6	9163006	NYLOC NUT

SINGLE FRONT DISC ASSEMBLY (INNER)

McCONNEL

Module(s): 22612.03

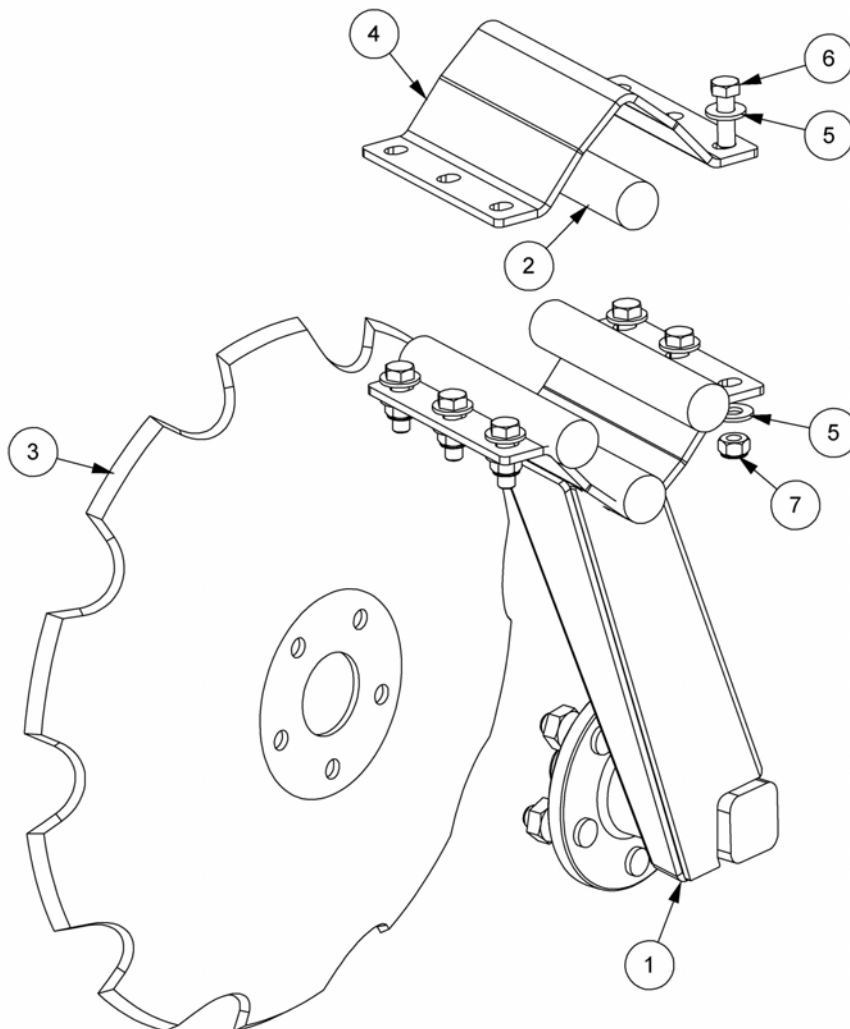

REF.	QTY.	PART No.	DESCRIPTION
		22612.03	SINGLE INNER FRONT DISC ASSEMBLY
1	1	22612.12	FRONT LEG & HUB (SINGLE INNER)
2	4	22546.39	RUBBER SHOCK ABSORBER
3	1	22546.11	CONCAVE SERRATED DISC
4	1	22546.60	DISC CLAMP
5	12	9100106	FLAT WASHER
6	6	9213086	BOLT
7	6	9163006	NYLOC NUT

SINGLE REAR DISC ASSEMBLY

McCONNEL

Module(s): 22612.04

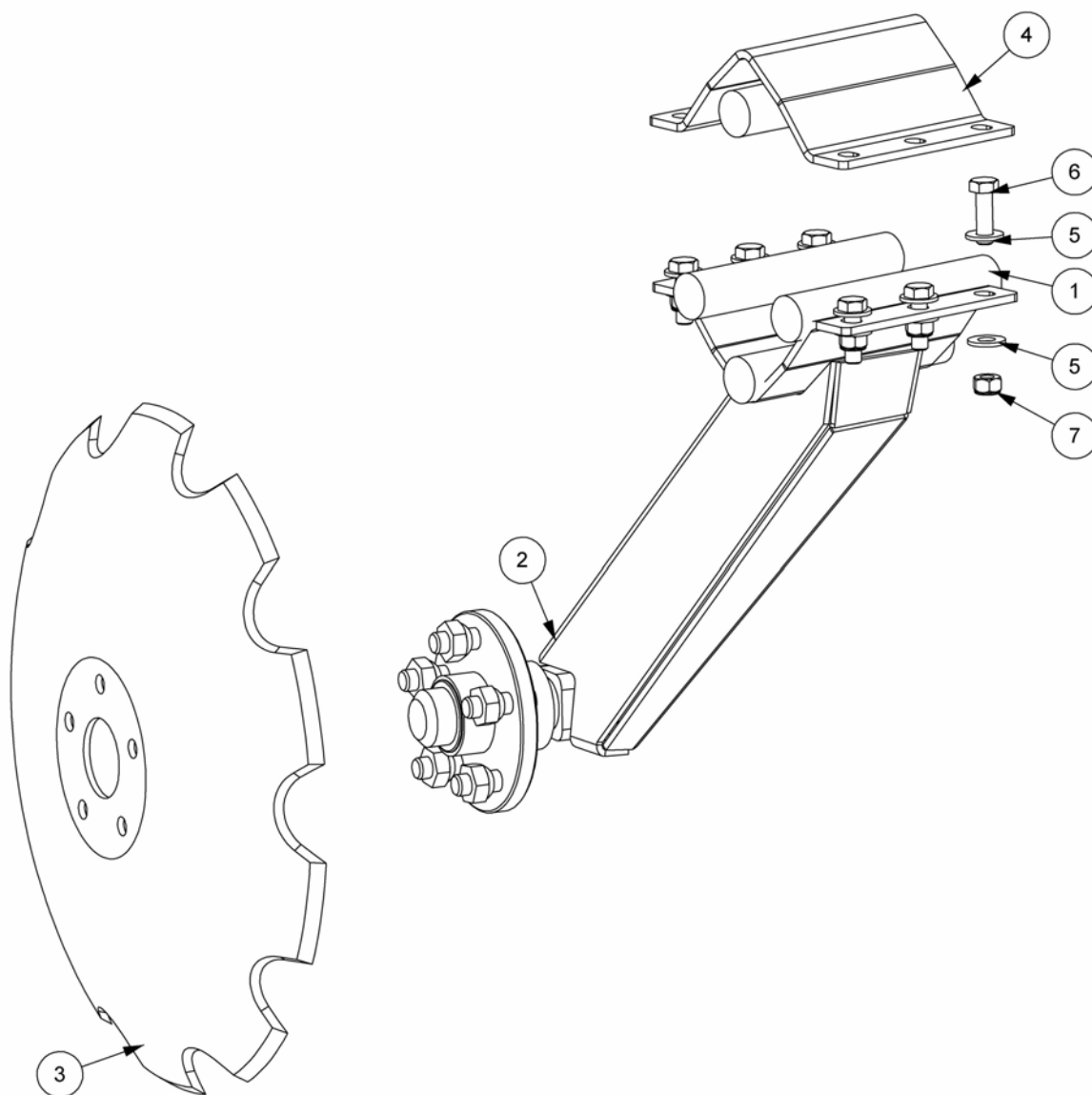

REF.	QTY.	PART No.	DESCRIPTION
		22612.04	SINGLE REAR DISC ASSEMBLY
1	4	22546.39	RUBBER SHOCK ABSORBER
2	1	22612.13	REAR LEG & HUB (SINGLE)
3	1	22546.11	CONCAVE SERRATED DISC
4	1	22546.60	DISC CLAMP
5	12	9100106	FLAT WASHER
6	6	9213086	BOLT
7	6	9163006	NYLOC NUT

DOUBLE REAR DISC ASSEMBLY

McCONNEL

Module(s): 22612.01

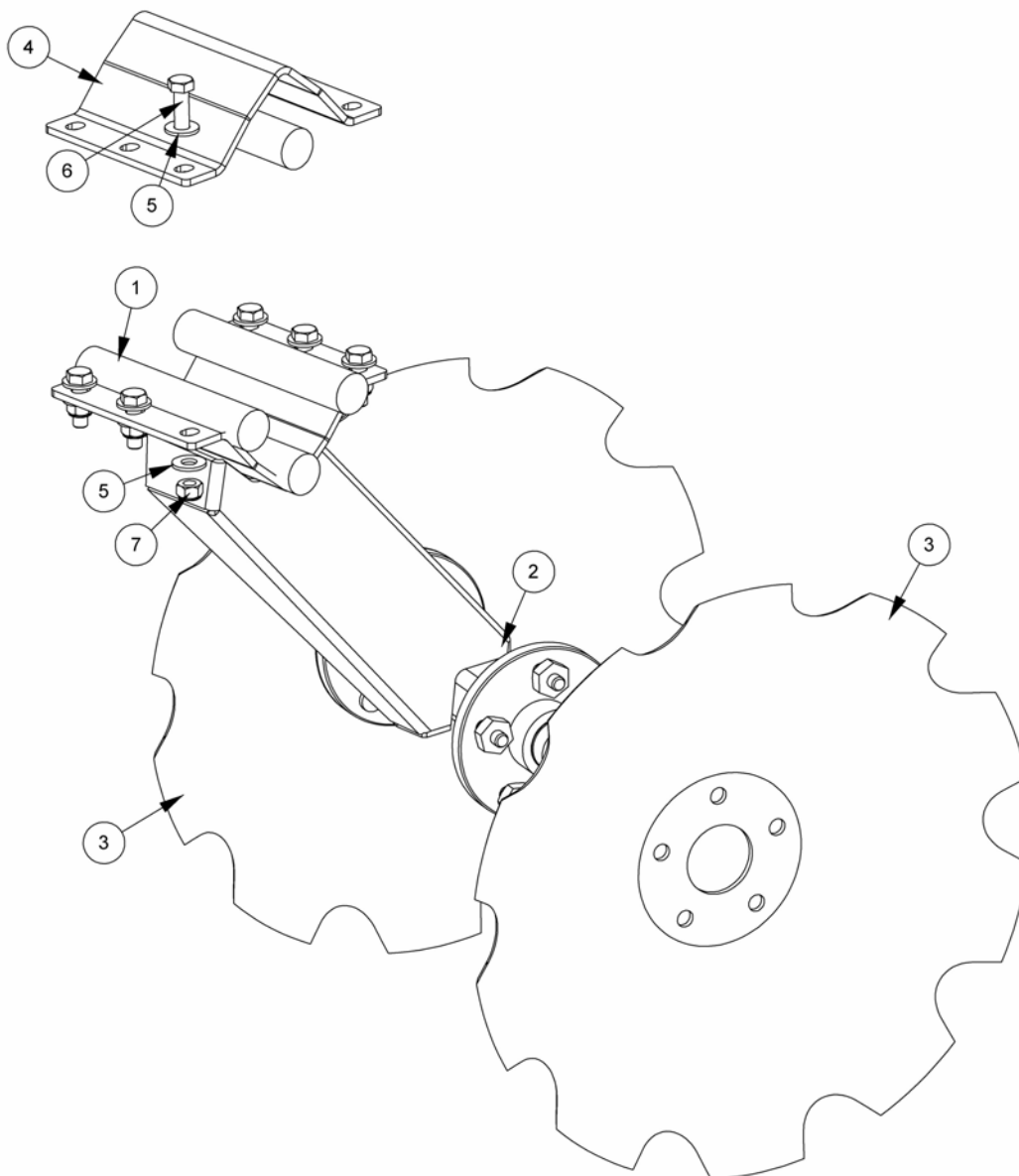

REF.	QTY.	PART No.	DESCRIPTION
		22612.01	DOUBLE REAR DISC ASSEMBLY
1	4	22546.39	RUBBER SHOCK ABSORBER
2	1	22612.10	REAR LEG & HUB (DOUBLE)
3	2	22546.11	CONCAVE SERRATED DISC
4	1	22546.60	DISC CLAMP
5	12	9100106	FLAT WASHER
6	6	9213086	BOLT
7	6	9163006	NYLOC NUT

Module(s): Sub-components of: 22612.10, 22612.11, 22612.12, 22612.13

Hub type fitted to machines manufactured prior to 07/09
 – identifiable by fixed stud (item 4) & separate nut (item 3)

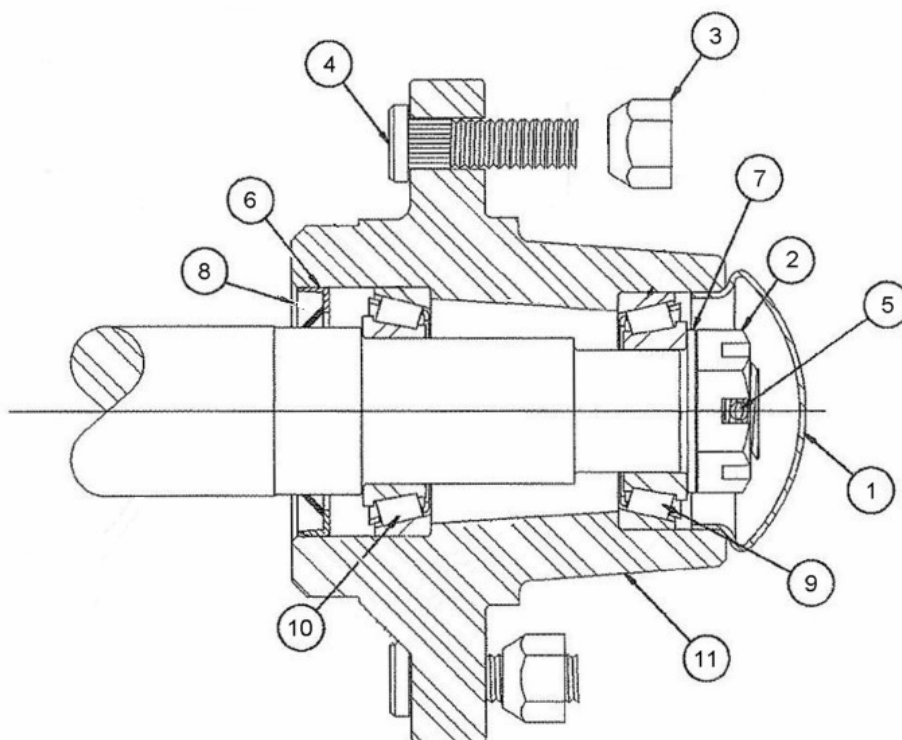

REF.	QTY.	PART No.	DESCRIPTION
		22612.10	REAR LEG & HUB (DOUBLE)
		22612.11	FRONT LEG & HUB (SINGLE OUTER)
		22612.12	FRONT LEG & HUB (SINGLE INNER)
		22612.13	REAR LEG & HUB (SINGLE)
1	1	1048075	HUB CAP
2	1	1048076	CASTLE NUT
3	5	1048077	WHEEL NUT
4	5	1048078	WHEEL STUD
5	1	1048079	SPLIT PIN
6	1	1048081	METAL SEAL
7	1	1048082	WASHER PLATE
8	1	1048083	WASHER PLATE
9	1	1048084	TAPERED ROLLER BEARING
10	1	1048085	TAPERED ROLLER BEARING
11	1	1048086	HUB CASTING

NOTE: Quantities stated are per individual hub.

Module(s): Sub-components of: 22612.10, 22612.11, 22612.12, 22612.13

**Hub type fitted to machines manufactured 07/09 onwards
 – identifiable by removable wheel studs (item 8)**

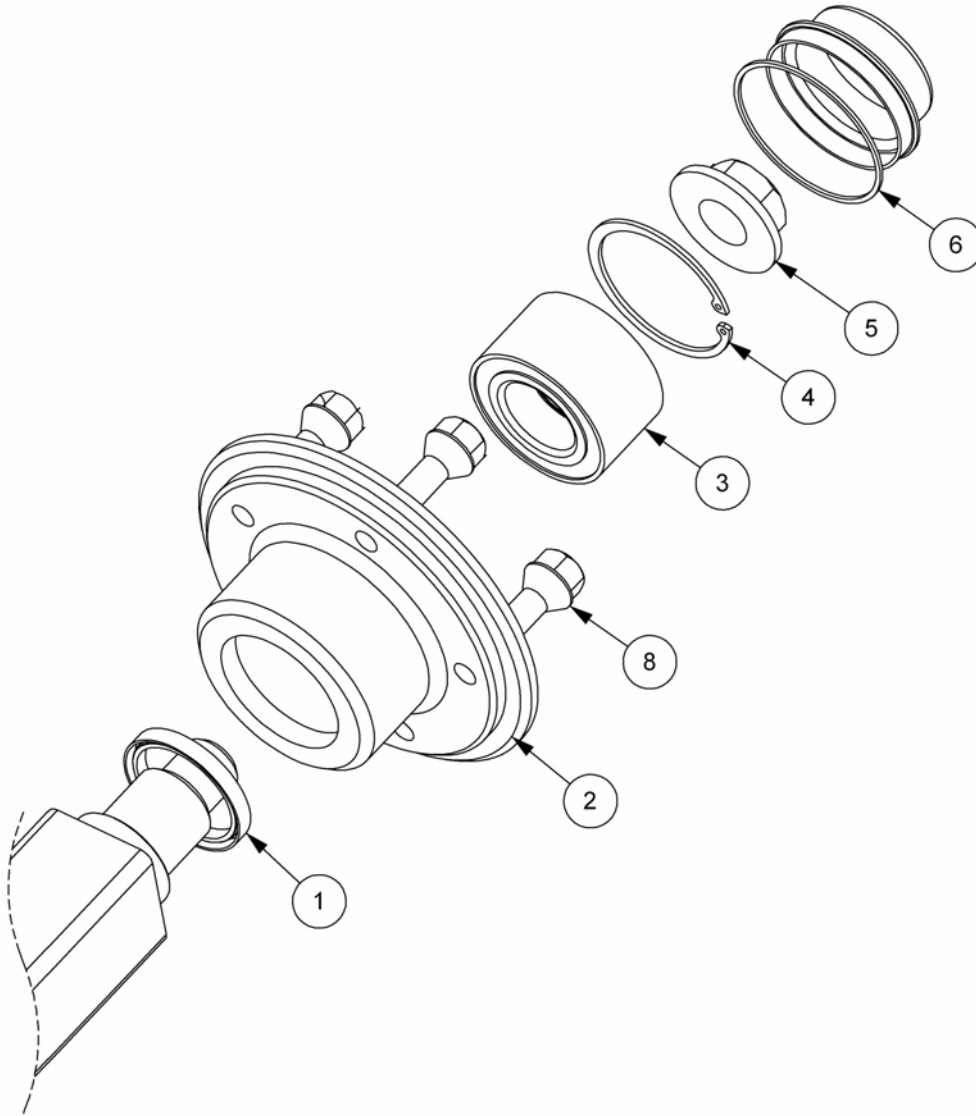

REF.	QTY.	PART No.	DESCRIPTION
		22612.10	REAR LEG & HUB (DOUBLE)
		22612.11	FRONT LEG & HUB (SINGLE OUTER)
		22612.12	FRONT LEG & HUB (SINGLE INNER)
		22612.13	REAR LEG & HUB (SINGLE)
1	1	8629261	SEAL
2	1	22546.64	HUB
3	1	0603234	DOUBLE SEALED BEARING
4	1	0411262	INTERNAL CIRCLIP
5	1	22546.66	FLANGE NUT
6	1	8600429	ANTI EXTRUSION RING
7	1	22546.65	GREASE CAP
8	5	22546.67	WHEEL STUD

NOTE: Quantities stated are per individual hub.

BREAKBACK LEG ASSEMBLIES (MECHANICAL)

McCONEL

Module(s): 1068701, 1068702

1068701 (Left Handed Leg)

1068702 (Right Handed Leg)

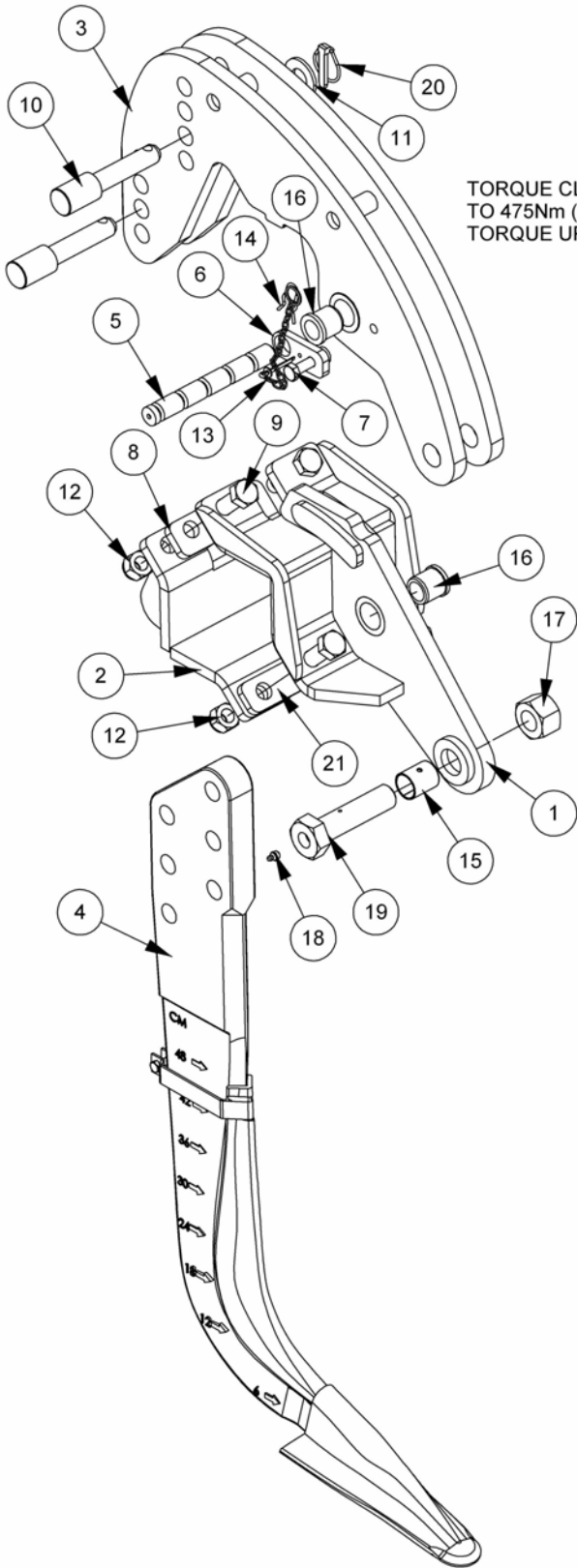

TORQUE CLAMP BOLTS ITEM 9 TO 475Nm (352lb-ft). TIGHTEN & TORQUE UPPER BOLTS FIRST.

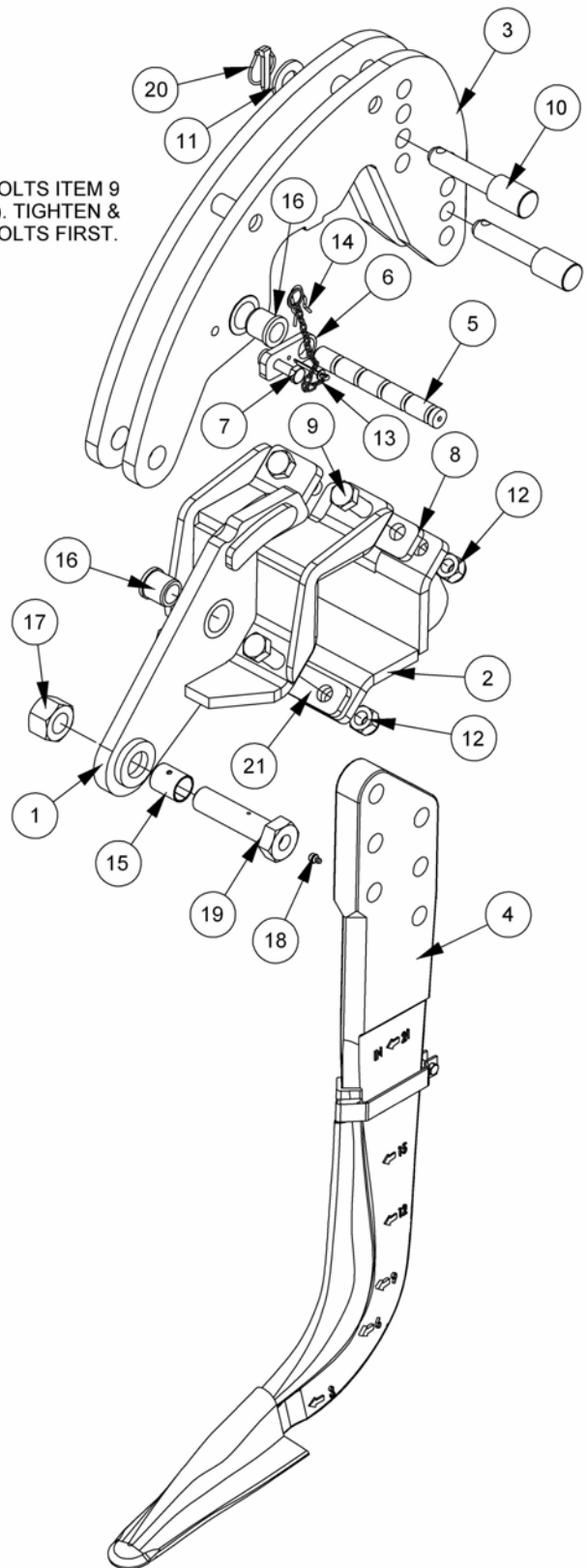

NOTE: Left & Right Handed does not refer to the particular side of the machine that the leg is fitted - it refers to the insertion direction of the replaceable shearbar when the leg is attached to the machine and the assembly is viewed from the rear.

BREAKBACK LEG ASSEMBLIES (MECHANICAL)



Module(s): 1068701, 1068702

REF.	QTY.	PART No.	DESCRIPTION
		1068701	LH BREAKBACK LEG (MECHANICAL)
		1068702	RH BREAKBACK LEG (MECHANICAL)
1	1	22520.03	CLAMP HEAD BRACKET - L/H (Assembly 1068701)
	1	22520.07	CLAMP HEAD BRACKET - R/H (Assembly 1068702)
2	1	22520.02	BOTTOM CLAMP
3	1	22520.04	BREAKBACK PLATES - L/H (Assembly 1068701)
	1	22520.05	BREAKBACK PLATES - R/H (Assembly 1068702)
4	1	1065797	30" LEG c/w SLIPPER POINT & SHIN
	1	43085.03	SHEARBOLT SHANK (LEG)
	1	1065921	SLIPPER POINT
	1	1065782	24" EUROSHIN ASSEMBLY - c/w:
	1	1065248	SHIN CLAMP
	1	9313064	BOLT
	1	9143004	NUT
5	1	22520.54	SHEAR BAR
6	1	22520.06	SHEAR BAR SPACER
7	1	9213106	BOLT
8	2	22520.55	CLAMP SPACER
9	4	9200053	BOLT
10	2	22520.70	LEG PIN
11	2	9100109	FLAT WASHER
12	4	9163008	NYLOC NUT
13	1	03.255.05	CHAIN & RING ASSEMBLY
14	1	22520.59	SPRING SHAFT CLIP
15	1	42654.08	BUSH
16	2	22520.56	HEADED BUSH
17	1	9100023	SELF-LOCKING NUT
18	1	0901121	GREASE NIPPLE
19	1	22520.68	SPECIAL BOLT
20	2	0431217	LINCH PIN
21	1	22520.72	CLAMP SPACER (DOUBLE)

NOTE: L/H & R/H assemblies comprise of identical components with the exception of items 1 & 3 which are handed components.

HYDRAULIC BREAKBACK LEG ASSEMBLY

Module(s): 1068711

McCONEL

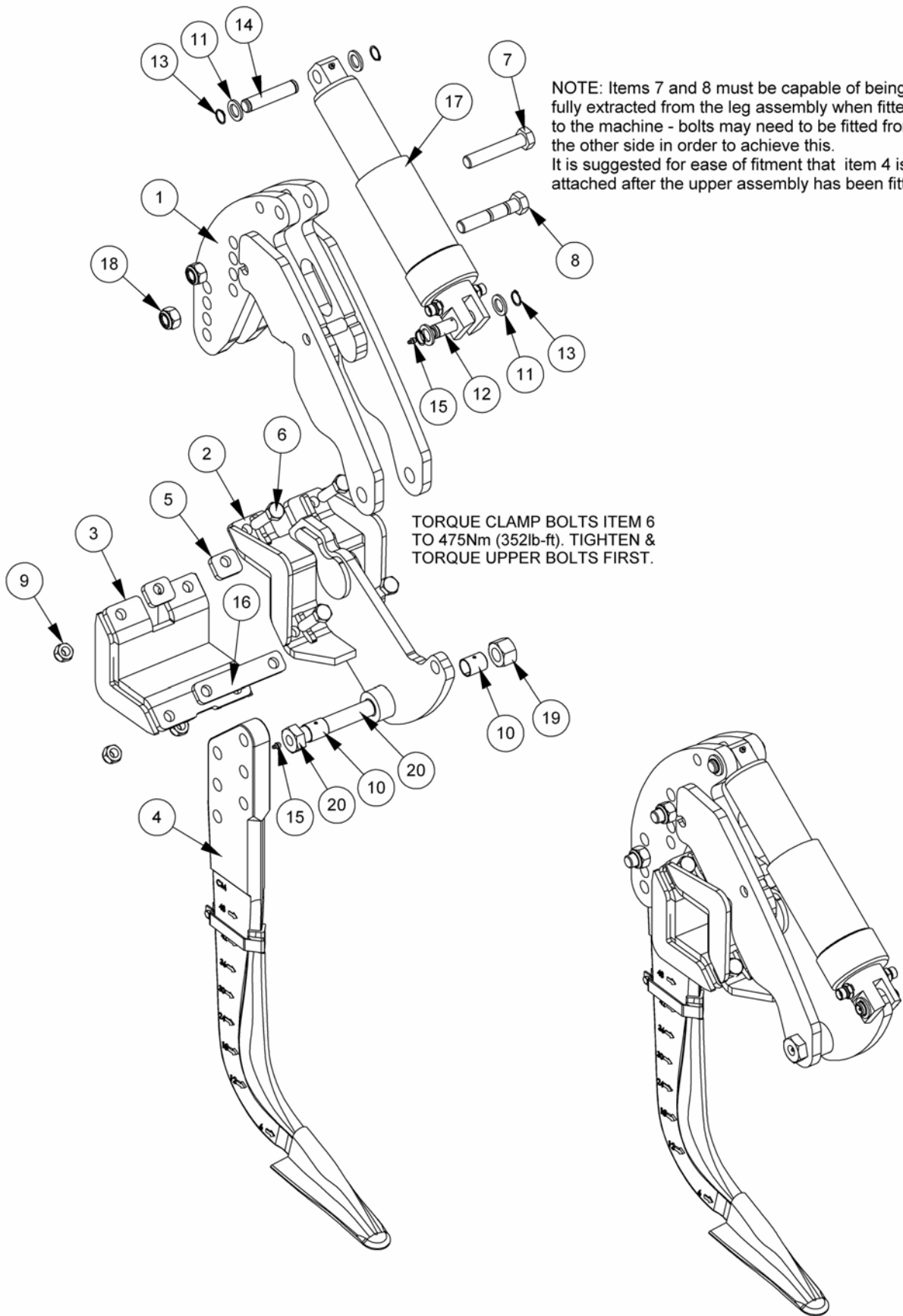

HYDRAULIC BREAKBACK LEG ASSEMBLY

McCONNEL

Module(s): 1068711

REF.	QTY.	PART No.	DESCRIPTION
		1068711	HYDRAULIC BREAKBACK LEG
1	1	22665.01	BREAKBACK PLATES
2	1	22665.02	CLAMP HEAD BRACKET
3	1	22665.03	BOTTOM CLAMP
4	1	1065797	30" LEG c/w SLIPPER POINT & SHIN
	1	43085.03	SHEARBOLT SHANK (LEG)
	1	1065921	SLIPPER POINT
	1	1065782	24" EUROSHIN ASSEMBLY - c/w:
	1	1065248	SHIN CLAMP
	1	9313064	BOLT
	1	9143004	NUT
5	2	22520.55	CLAMP SPACER
6	4	9200053	BOLT
7	1	9213269	BOLT
8	1	22665.50	SHEAR BOLT
9	4	9163008	NYLOC NUT
10	2	42654.08	BUSH
11	4	22520.66	SPACER WASHER
12	1	22520.67	RAM PIN
13	4	0401116	EXTERNAL CIRCLIP
14	1	22665.45	RAM PIN
15	2	0901121	GREASE NIPPLE
16	1	22665.39	CLAMP PLATE SPACER (DOUBLE)
17	1	22602.03	DISPLACEMENT CYLINDER
18	2	9163009	NYLOC NUT
19	1	9100023	SELF-LOCKING NUT
20	1	22665.46	SPECIAL BOLT

30" SHANK ASSEMBLY

Module(s): 1065797

McCONEL

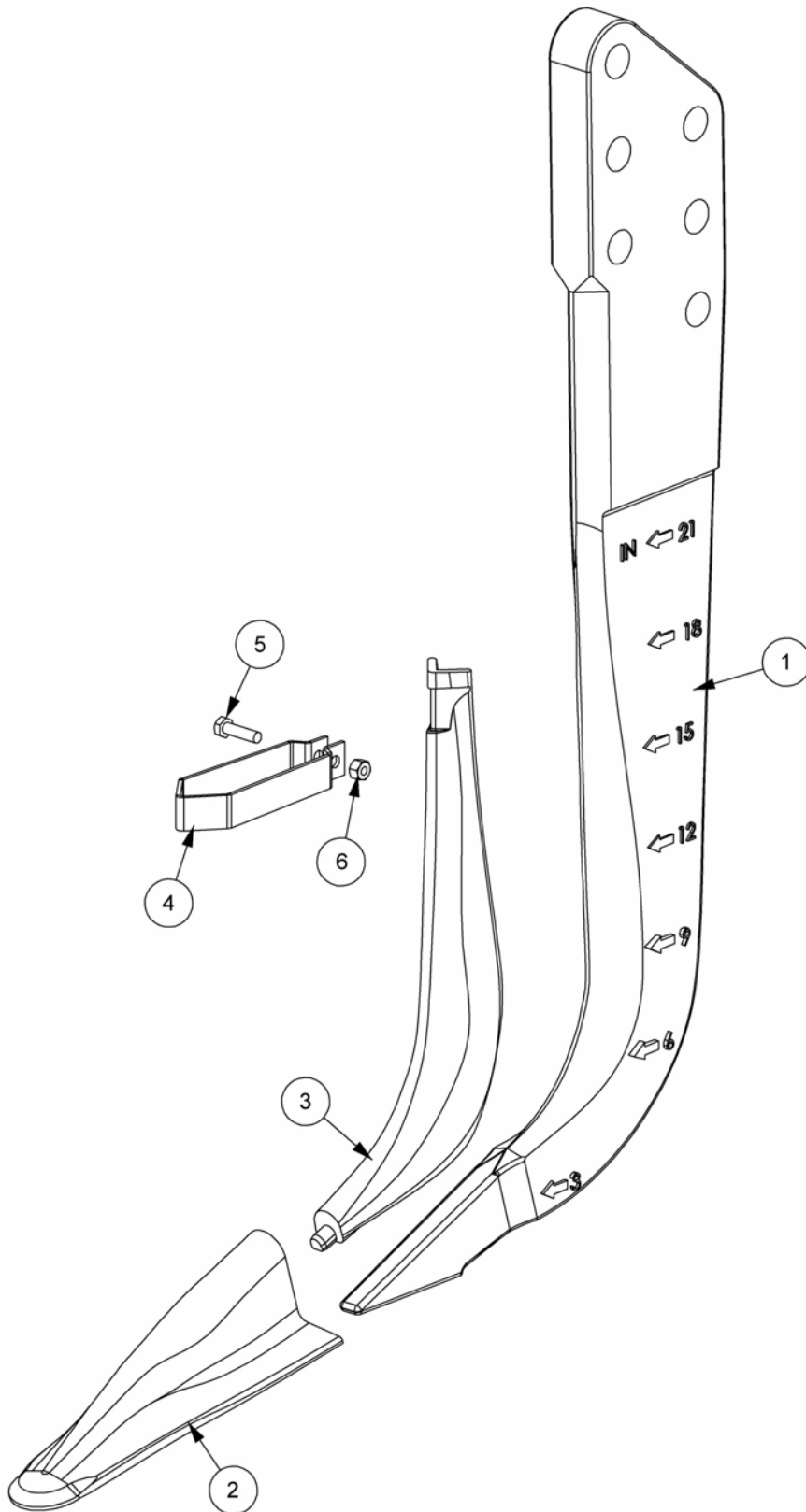

30" SHANK ASSEMBLY**McCONNEL**

Module(s): 1065797

REF.	QTY.	PART No.	DESCRIPTION
		1065797	30" LEG c/w SLIPPER POINT & SHIN
1	1	43085.03	SHEARBOLT SHANK (LEG)
2	1	1065921	SLIPPER POINT
3	1	1065782	24" EUROSHIN ASSEMBLY c/w:
4	1	1065248	SHIN CLAMP
5	1	9313064	BOLT
6	1	9143004	NUT

90MM DISPLACEMENT CYLINDER

McCONEL

Module(s): 22602.03

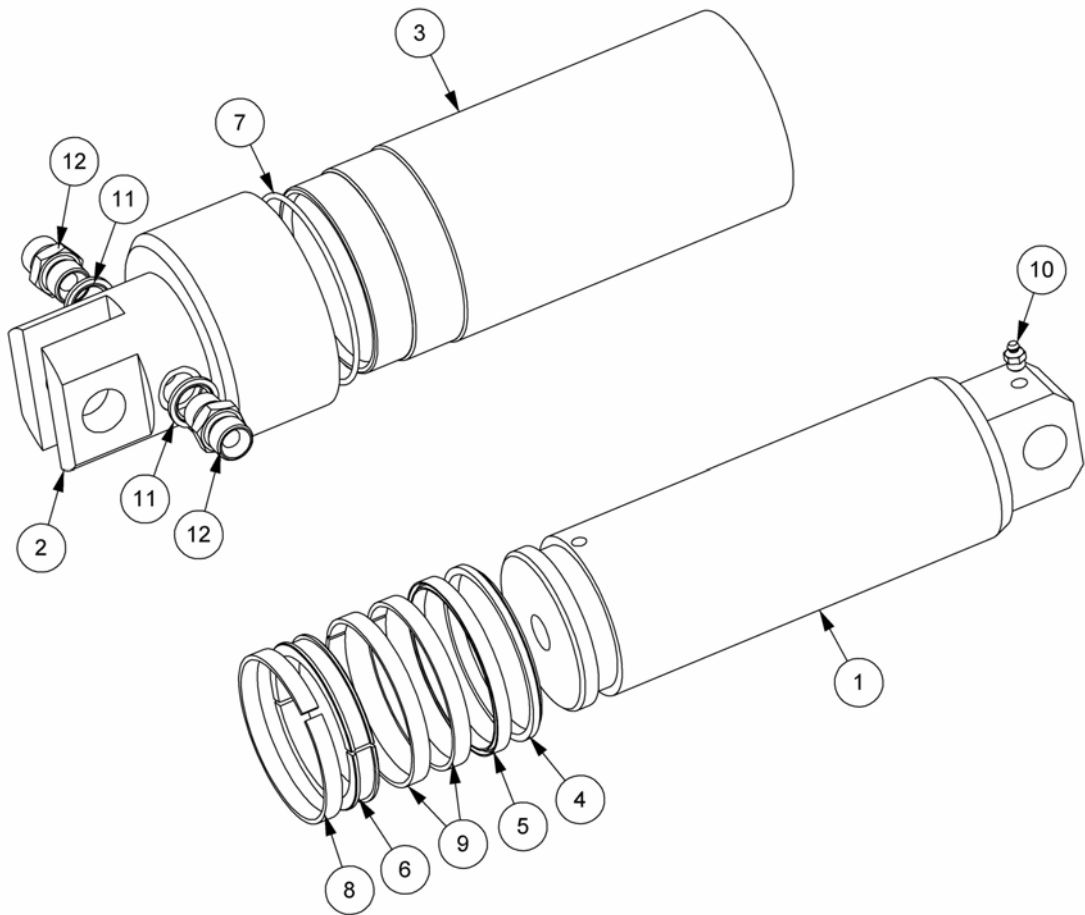

90MM DISPLACEMENT CYLINDER

McCONNEL

Module(s): 22602.03

REF.	QTY.	PART No.	DESCRIPTION
		22602.03	DISPLACEMENT CYLINDER
1	1	22603.37	CHROME ROD
2	1	22603.39	BLANK END
3	1	22603.38	OUTER TUBE
4	1	8629258	WIPER SEAL
5	1	8629257	ROD SEAL
6	1	8629259	PISTON HOUSING
7	1	8700746	O RING
8	1	8629256	BEARING RING
9	2	8629255	BEARING RING
10	1	0901121	GREASE NIPPLE
11	2	8650104	BONDED SEAL
12	2	8581110	ADAPTOR
		8699275	SEAL KIT

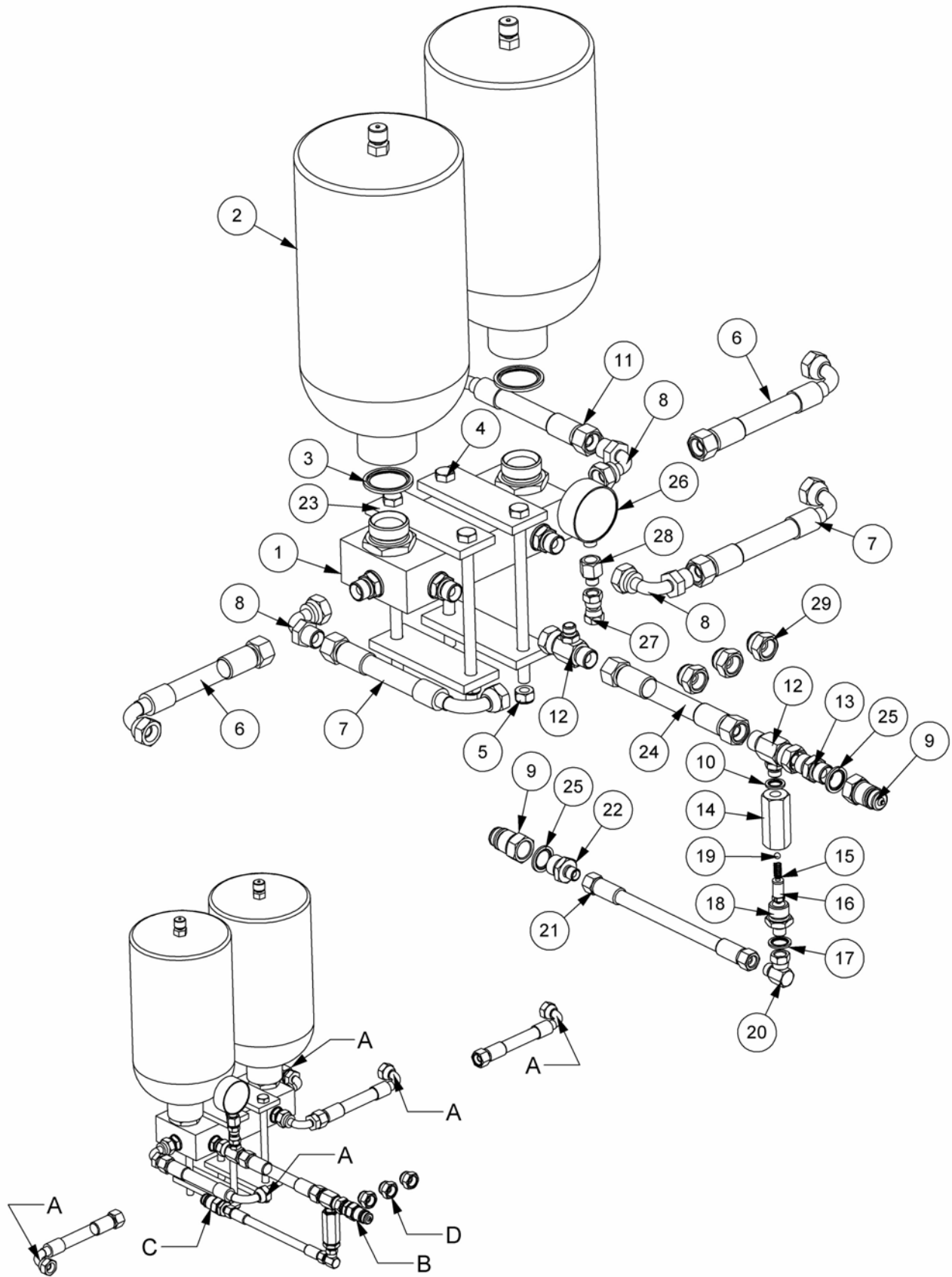

KEY

- A = CONNECT TO LEG RAM
- B = CONNECT TO TRACTOR SPOOL
- C = CONNECT TO TRACTOR SPOOL (TANK)
- D = CONNECT TO SPARE RAM PORT

Module(s): 1068752

REF.	QTY.	PART No.	DESCRIPTION
		1068752	HYDRAULIC INSTALLATION - 5 Leg Models
1	1	22632.01	MANIFOLD ASSEMBLY
2	2	22541.08	HYDRACUSHION ACCUMULATOR
3	2	8650109	BONDED SEAL
4	4	05.292.30	BOLT
5	4	9163006	NYLOC NUT
6	2	10.006.21	HOSE - 1/2" BSP FS/F90 x 1100mm
7	2	10.006.16	HOSE - 1/2" BSP FS/F90 x 800mm
8	3	8581215	90° SWEPT ADAPTOR
9	2	8590074	QUICK RELEASE
10	1	8650102	BONDED SEAL
11	1	10.006.08	HOSE - 1/2" BSP FS/F90 x 400mm
12	2	04.056.25	ADAPTOR TEE
13	1	8581110	ADAPTOR
14	1	8130178	RELIEF VALVE HOUSING
15	1	8116011	SPRING
16	1	8130108	RELIEF VALVE (125BAR)
17	1	8650103	BONDED SEAL
18	1	8130083	ADAPTOR RELIEF BODY
19	1	0905108	STEEL BALL
20	1	8581190	ADAPTOR ELBOW 90°
21	1	10.001.10	HOSE - 1/4" BSP FS/FS x 500mm
22	1	8581172	ADAPTOR
23	4	42073.01	CLAMP PLATE
24	1	10.005.25	HOSE - 1/2" BSP FS/FS x 1500mm
25	2	8650104	BONDED SEAL
26	1	8004296	PRESURE GAUGE
27	1	T6943	SWIVEL ADAPTOR
28	1	8581560	GAUGE FISED
29	3	8582054	BLANKING CAP

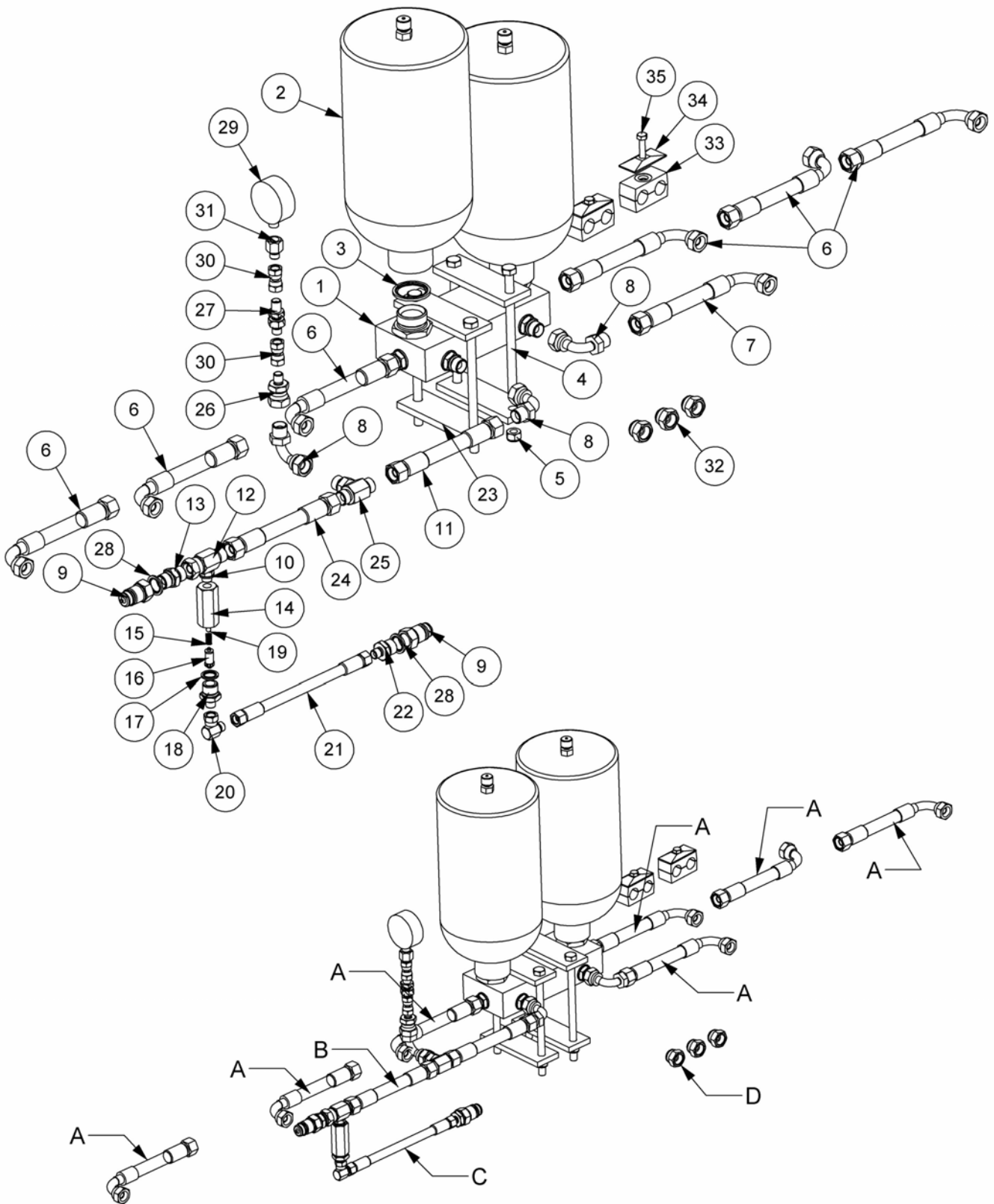

KEY
 A = CONNECT TO LEG RAM
 B = CONNECT TO TRACTOR SPOOL
 C = CONNECT TO TRACTOR SPOOL (TANK)
 D = CONNECT TO SPARE RAM PORT

Module(s): 1068753

REF.	QTY.	PART No.	DESCRIPTION
		1068753	HYDRAULIC INSTALLATION - 7 Leg Models
1	1	22632.01	MANIFOLD ASSEMBLY
2	2	22541.08	HYDRACUSHION ACCUMULATOR
3	2	8650109	BONDED SEAL
4	4	05.292.30	BOLT
5	4	9163006	NYLOC NUT
6	6	10.006.18	HOSE - 1/2" BSP FS/F90 x 900mm
7	1	10.006.22	HOSE - 1/2" BSP FS/F90 x 1200mm
8	3	8581215	90° SWEPT ADAPTOR
9	2	8590074	QUICK RELEASE
10	1	8650102	BONDED SEAL
11	1	10.005.12	HOSE - 1/2" BSP FS/FS x 600mm
12	1	04.056.25	ADAPTOR TEE
13	1	8581110	ADAPTOR
14	1	8130178	RELIEF VALVE HOUSING
15	1	8116011	SPRING
16	1	8130108	RELIEF VALVE (125BAR)
17	1	8650103	BONDED SEAL
18	1	8130083	ADAPTOR RELIEF BODY
19	1	0905108	STEEL BALL
20	1	8581190	ADAPTOR ELBOW 90°
21	1	10.001.10	HOSE - 1/4" BSP FS/FS x 500mm
22	1	8581172	ADAPTOR
23	4	42073.01	CLAMP PLATE
24	1	10.005.25	HOSE - 1/2" BSP FS/FS x 1500mm
25	1	EYT0051	ADAPTOR
26	1	EYS0035	ADAPTOR
27	1	7105153	BULKHEAD ADAPTOR
28	2	8650104	BONDED SEAL
29	1	8004296	PRESURE GAUGE
30	2	T6943	SWIVEL ADAPTOR
31	1	8581560	GAUGE FISED
32	3	8582054	BLANKING CAP
33	2	22616.01	HOSE CLAMP (TWIN)
34	2	22616.02	HOSE COVER PLATE
35	2	9213094	BOLT

PACKER ROLLER ASSEMBLY (600mm)

McCONEL

Module(s): 1068794

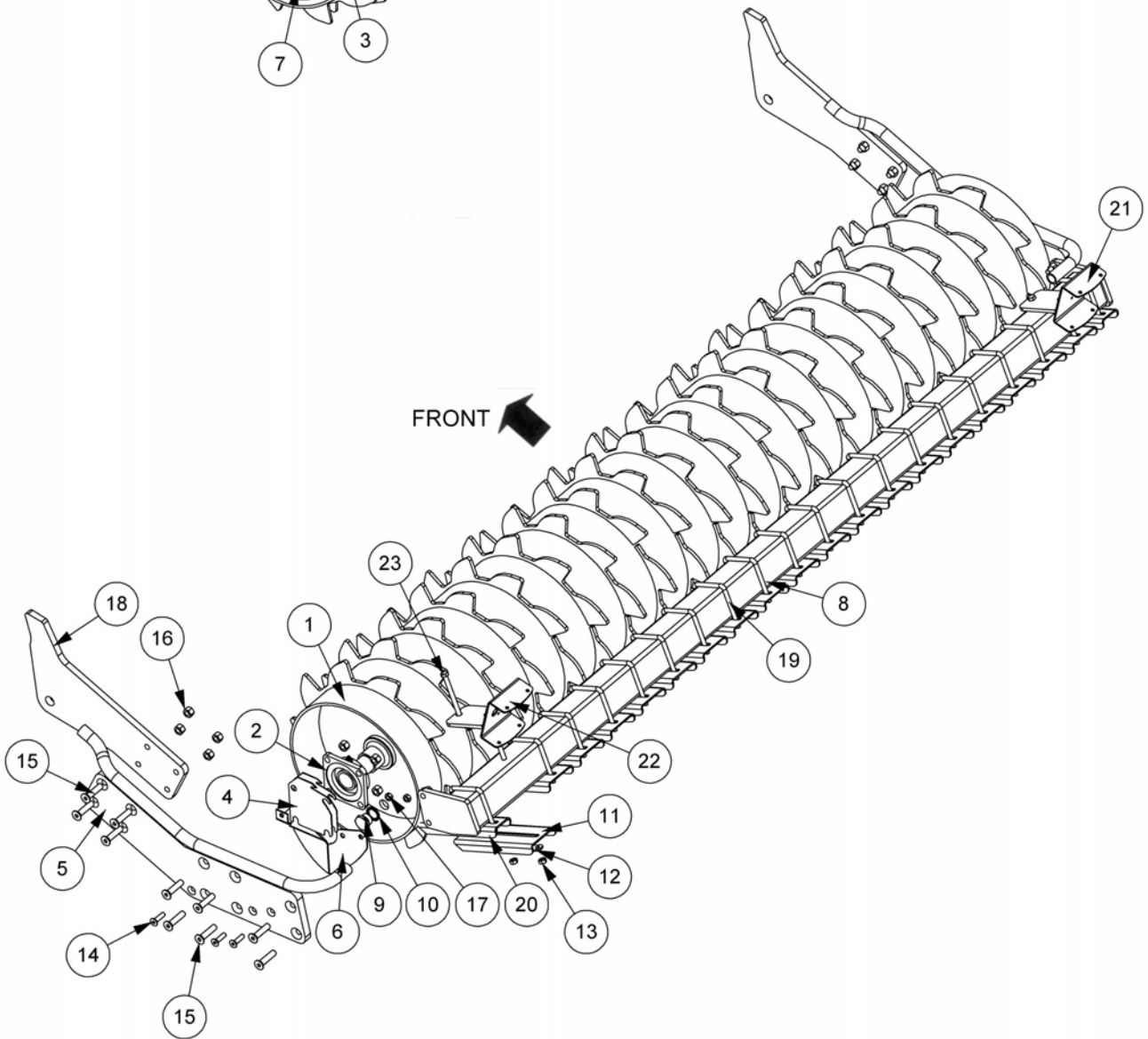
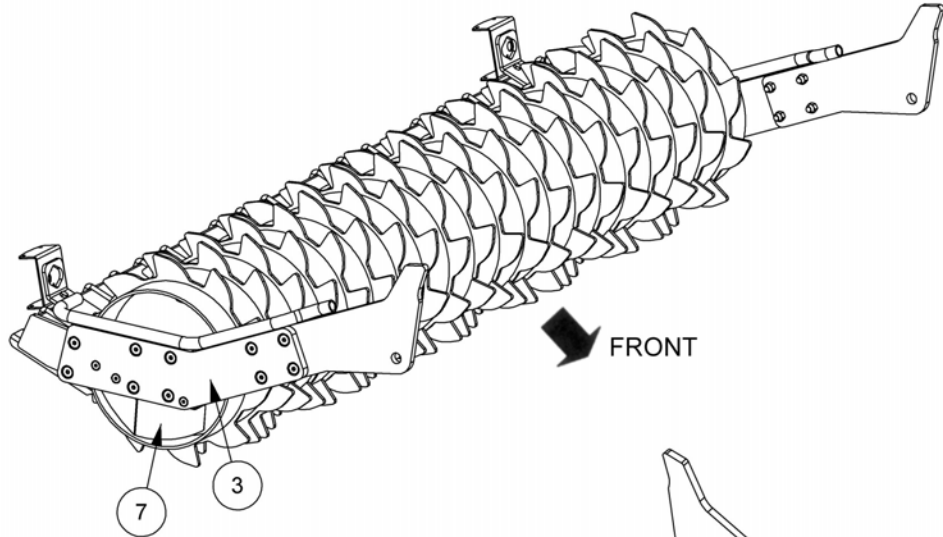

Module(s): 1068794

REF.	QTY.	PART No.	DESCRIPTION
		1068794	PACKER ROLLERS ASSEMBLY (600mm)
1	1	22541.13	STANDARD PACKER ROLLER
2	2	0600062	BEARING
3	1	22541.09	ATTACHMENT PLATE - L/H
4	4	21124.03	BEARING PACKER
5	1	22541.10	ATTACHMENT PLATE - R/H
6	1	21335.36	SCRAPER - L/H
7	1	21335.37	SCRAPER - R/H
8	1	22541.07	SCRAPER BAR
9	2	8581159	BLANKING PLUG
10	2	8650108	BONDED SEAL
11	19	42072.06	SCRAPER
12	21	42072.07	WASHER
13	42	T8095	SELF-LOCKING NUT
14	6	9353096	CAPSCREW
15	20	9353147	SETSCREW
16	20	9143007	SELF-LOCKING NUT
17	6	9117006	NUT
18	2	22541.55	ROLLER ATTACHMENT PLATE
19	19	42072.08	U BOLT
20	2	42072.09	SCRAPER PLATE (NARROW)
21	1	22541.12	LIGHT BRACKET ASSEMBLY - L/H
22	1	22541.11	LIGHT BRACKET ASSEMBLY - R/H
23	4	0211445	BOLT

RIDGE PACKER ROLLER ASSEMBLY (600mm)

McCONEL

Module(s): 1068792

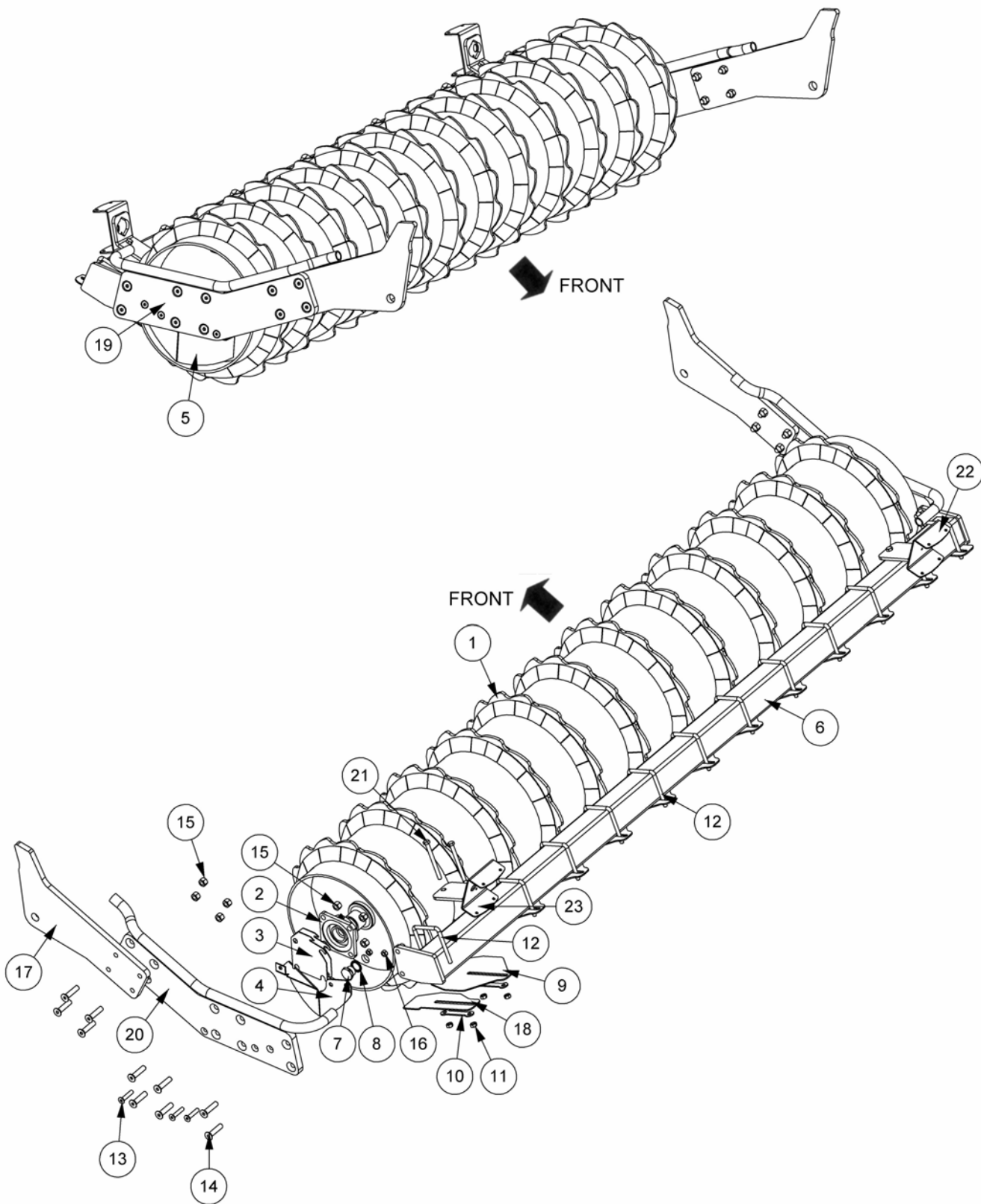

Module(s): 1068792

REF.	QTY.	PART No.	DESCRIPTION
		1068792	RIDGE PACKER ROLLER ASSEMBLY (600mm)
1	1	22541.06	RIDGE ROLLER (600mm)
2	2	0600062	BEARING
3	4	21124.03	BEARING PACKER
4	1	21335.36	SCRAPER - L/H
5	1	21335.37	SCRAPER - R/H
6	1	22541.07	SCRAPER BAR
7	2	8581159	BLANKING PLUG
8	2	8650108	BONDED SEAL
9	11	42072.12	SCRAPER
10	13	42072.07	WASHER
11	26	T8095	SELF-LOCKING NUT
12	11	42072.08	U BOLT
13	6	9353126	CAPSCREW
14	20	9353147	SETSCREW
15	20	9143007	SELF-LOCKING NUT
16	6	9117006	NUT
17	2	22541.55	ROLLER ATTACHMENT PLATE
18	2	42072.13	END SCRAPER
19	1	22541.09	ATTACHMENT PLATE - L/H
20	1	22541.10	ATTACHMENT PLATE - R/H
21	4	0211445	BOLT
22	1	22541.12	LIGHT BRACKET - L/H
23	1	22541.11	LIGHT BRACKET - R/H

RIDGE PACKER ROLLER ASSEMBLY (800mm)

Module(s): 1068790

McCONEL

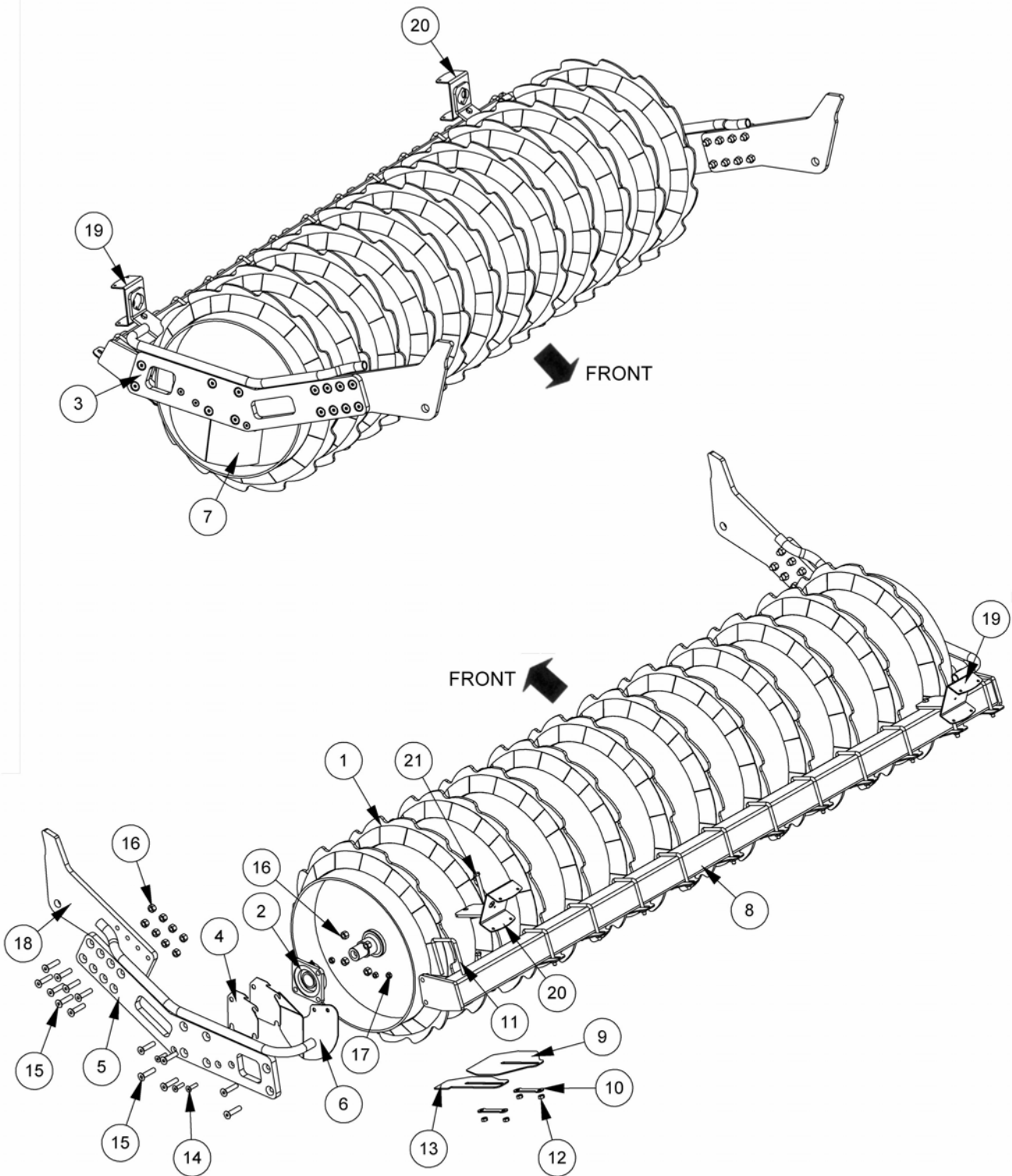

Module(s): 1068790

REF.	QTY.	PART No.	DESCRIPTION
		1068790	RIDGE PACKER ROLLER ASSEMBLY (800mm)
1	1	22541.01	RIDGE ROLLER (800mm)
2	2	0600062	BEARING
3	1	22541.15	ATTACHMENT PLATE - L/H
4	4	21124.03	BEARING PACKER
5	1	22541.14	ATTACHMENT PLATE - R/H
6	1	22541.34	SCRAPER - L/H
7	1	22541.35	SCRAPER - R/H
8	1	22541.07	SCRAPER BAR
9	11	42072.15	SCRAPER
10	13	42072.07	WASHER
11	11	42072.08	U BOLT
12	26	T8095	SELF-LOCKING NUT
13	2	42072.16	END SCRAPER
14	6	9353096	CAPSCREW
15	28	9353147	SETSCREW
16	28	9143007	SELF-LOCKING NUT
17	6	9117006	NUT
18	2	22541.70	ROLLER ATTACHMENT PLATE
19	1	22541.12	LIGHT BRACKET - L/H
20	1	22541.11	LIGHT BRACKET - R/H
21	4	0211445	BOLT

GUTTLER ROLLER ASSEMBLY

McCONEL

Module(s): 1068793

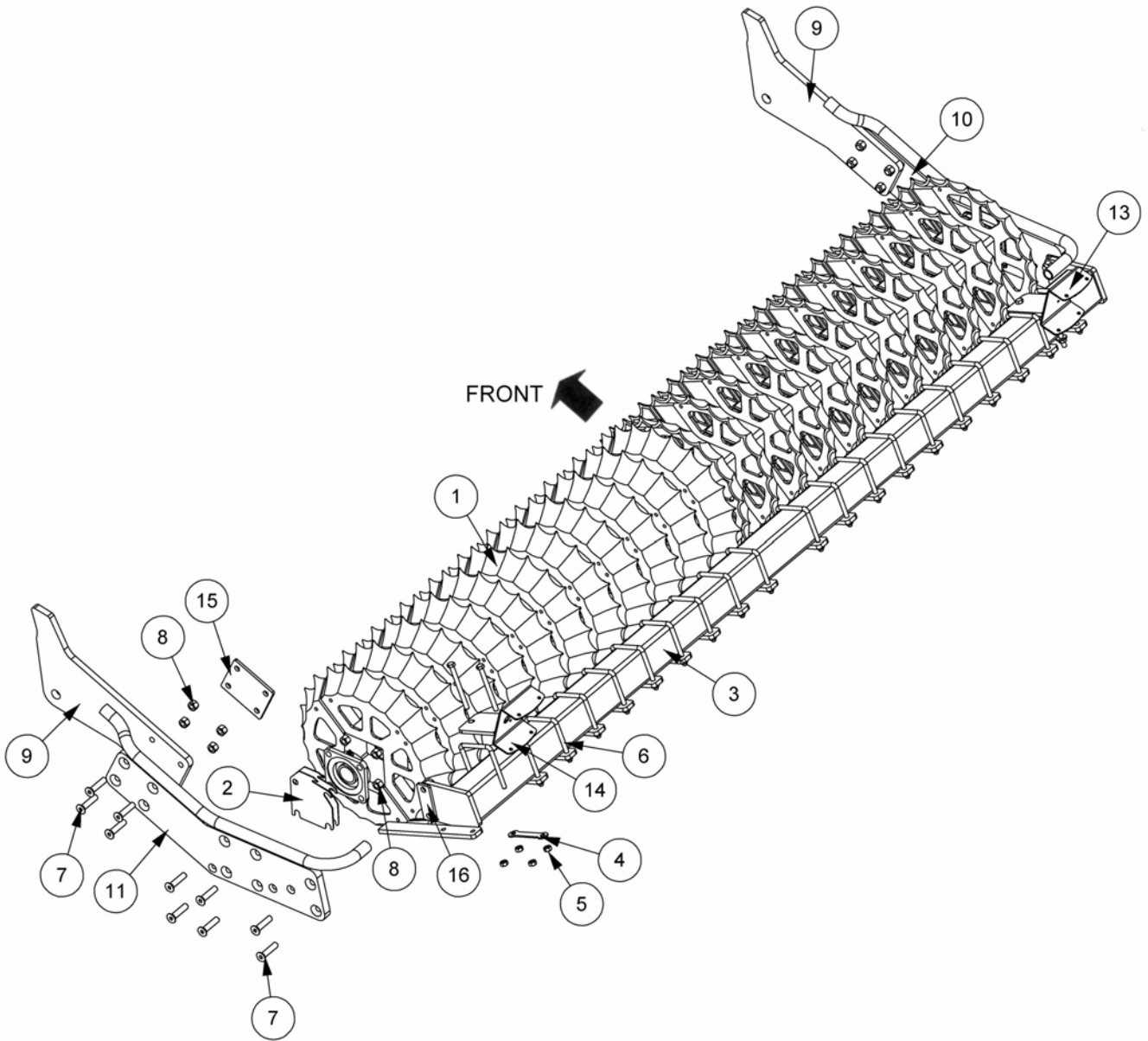

GUTTLER ROLLER ASSEMBLY**McCONNEL**

Module(s): 1068793

REF.	QTY.	PART No.	DESCRIPTION
		1068793	GUTTLER ROLLER ASSEMBLY
1	1	22618.01	GUTTLER ROLLER
2	4	21124.03	BEARING PACKER
3	1	22541.07	SCRAPER BAR
4	2	42072.07	WASHER
5	48	T8095	SELF-LOCKING NUT
6	22	42072.08	U BOLT
7	20	9353147	SETSCREW
8	21	9143007	SELF-LOCKING NUT
9	2	22541.55	ROLLER ATTACHMENT PLATE
10	1	22541.09	ATTACHMENT PLATE - L/H
11	1	22541.10	ATTACHMENT PLATE - R/H
12	4	0211445	BOLT
13	1	22541.12	LIGHT BRACKET - L/H
14	1	22541.11	LIGHT BRACKET - R/H
15	2	22541.63	SPACER PLATE
16	2	22541.64	SPACER PLATE
17	22	22619.01	GUTTLER SCRAPER

REAR LIGHTING KIT

McCONNEL

Module(s): 22572.04

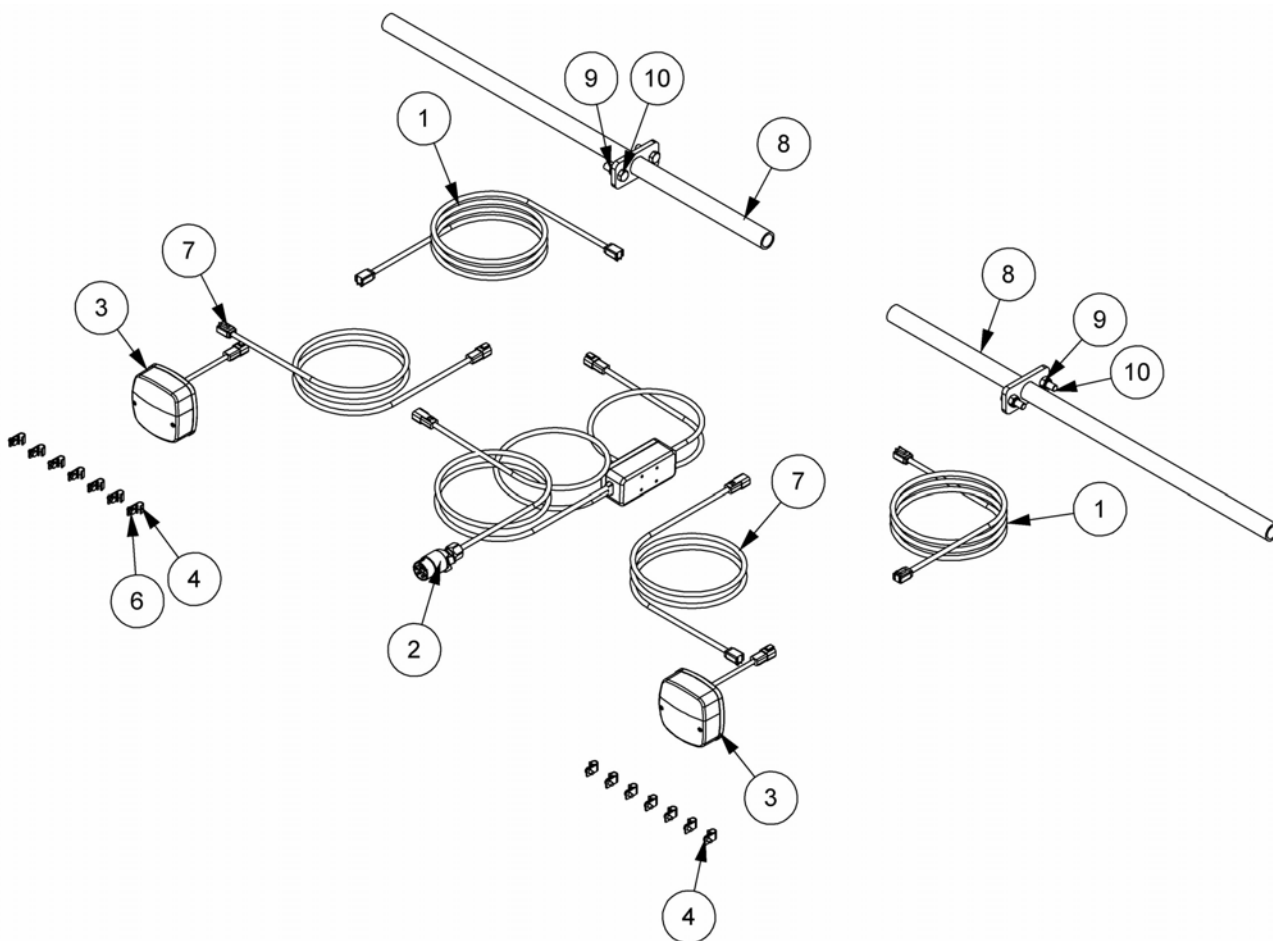

REF.	QTY.	PART No.	DESCRIPTION
		22572.04	DISCAERATOR REAR LIGHTING KIT
1	2	22572.05	WIRING LOOM
2	1	22572.08	JUNCTION BOX c/w PLUGS AND CABLES
3	2	45642.02	COMBINATION LAMP ASSEMBLY
4	14	21151.01	D CLIP
5	14	9100203	SPRING WASHER
6	14	9313013	SETSCREW
7	2	22572.07	WIRING LOOM
8	2	22521.06	CABLE HOLDER
9	4	9163006	NYLOC NUT
10	4	9213086	BOLT

Module(s): 1068730

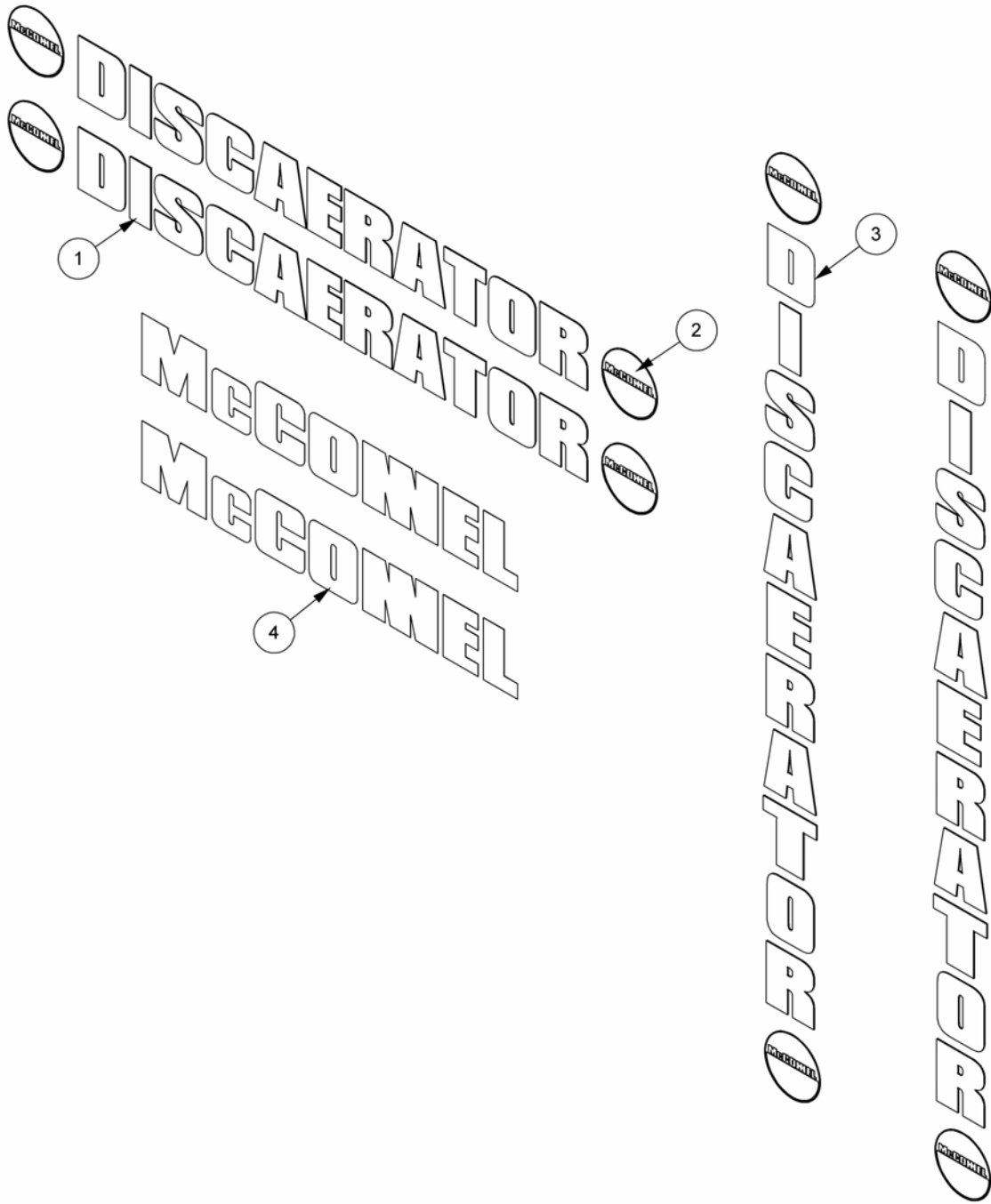

REF.	QTY.	PART No.	DESCRIPTION
		1068730	DISCAERATOR DECAL KIT
1	2	1290792	DECAL - 'DISCAERATOR'
2	8	1290742	DECAL - MCCONNEL ROUNDEL
3	2	1290793	DECAL - 'DISCAERATOR' (VERTICAL)
4	2	1290255	DECAL - 'MCCONNEL'



McConnel Limited, Temeside Works, Ludlow, Shropshire SY8 1JL. England.
Telephone: 01584 873131. Facsimile: 01584 876463. www.mcconnel.com