

# **GALAX** **4100.KD**



## **CATALOGUE DE PIÈCES DÉTACHÉES**

## Contents

• General glossary.....	3
• Full tank. ....	5
• Bras 1 complete.....	8
• Strut complete.....	9
• Assemble arm 2.....	10
• Support de Saw Head.....	<b>Erreur ! Signet non défini.</b>
• Saw Head 4420 – Machine-welded element.....	16
• Saw Head 5420 – Machine-welded element.....	18
• Bearing assembly .....	<b>Erreur ! Signet non défini.</b>
• Bearing assembly et des plates sur le Casing .....	21
• Safety stickers.....	29

For any maintenance work on the pruning equipment, it is essential to contact us to avoid any mishandling.

For optimum performance, use only COUP'ECO spare parts in order to benefit from the latest refinements.

Buy your original COUP'ECO parts from your local dealer.

Always state the type and serial number of your machine that you will find on its nameplate and the Reference number of the desired part.

Improvements made by the company may have changed some of the parts shown in this manual. The most recent part will always be supplied when interchangeable with the previous model.

Do not hesitate to contact us for any information, as well as for special designs or products.

- **General glossary**

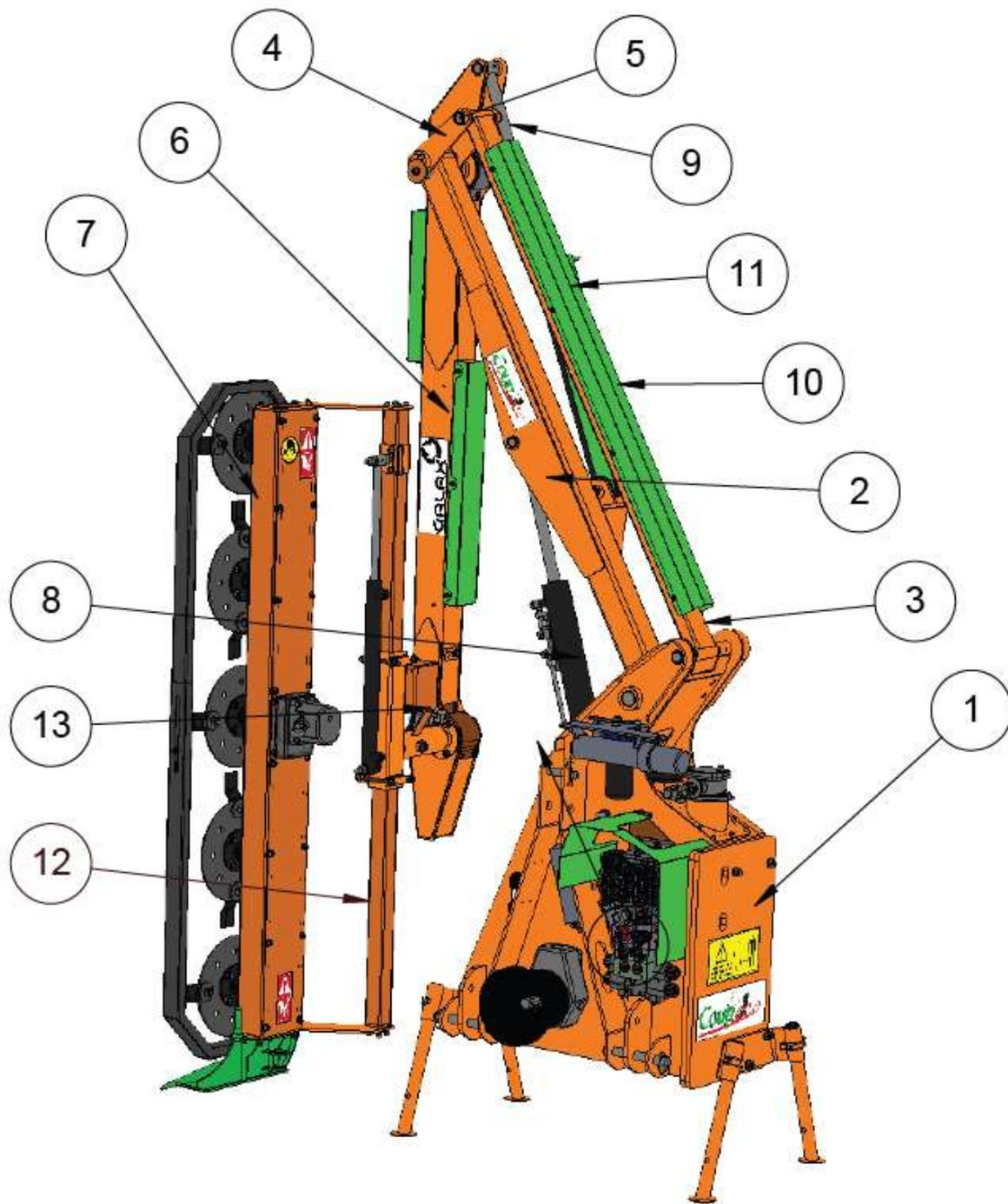

Rep	Reference	Description	Qty
1	TH.410.100M	Assembled frame	1
2	TH.440.250	Arm 1 complete	1
3	TH.440.300	Strut	1
4	TH.440.400	Articulated rod	2
5	TH.440.404	Axis 404 for articulated rod	1
6	TH.440.800	Assemble arm 2	1
7	TH.440.050	Saw Head	1
8	TH.440.V01	Arm Cylinder 1	1
9	TH.440.V02	Arm Cylinder 2	1
10	TH.440.C03	Protective casing C03	1
11	TH.440.C04	Protective casing C04	1
12	TH.440.650	Cutter bar offset	1
13		Sensor COBO 360°	1



- Full tank

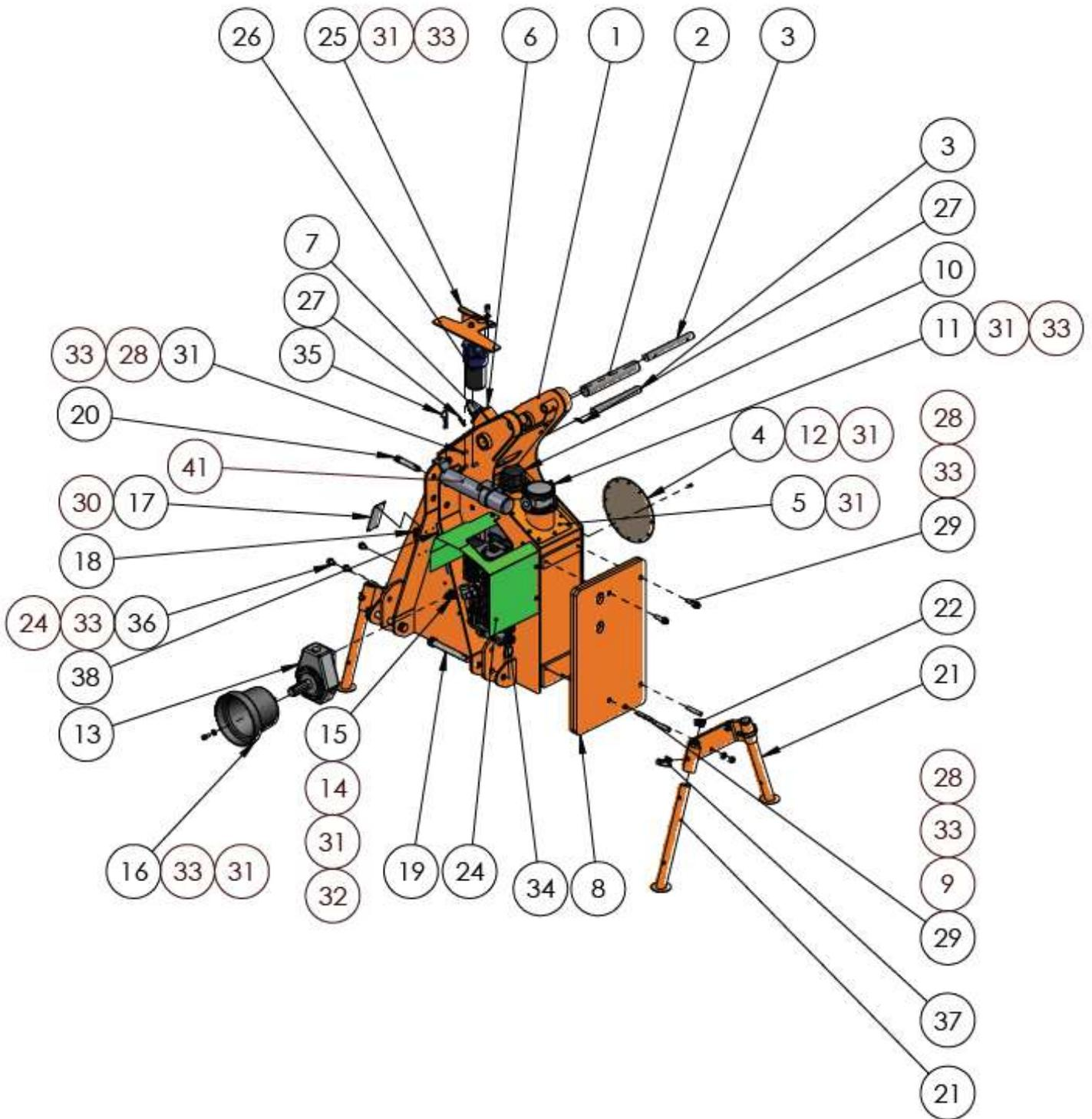

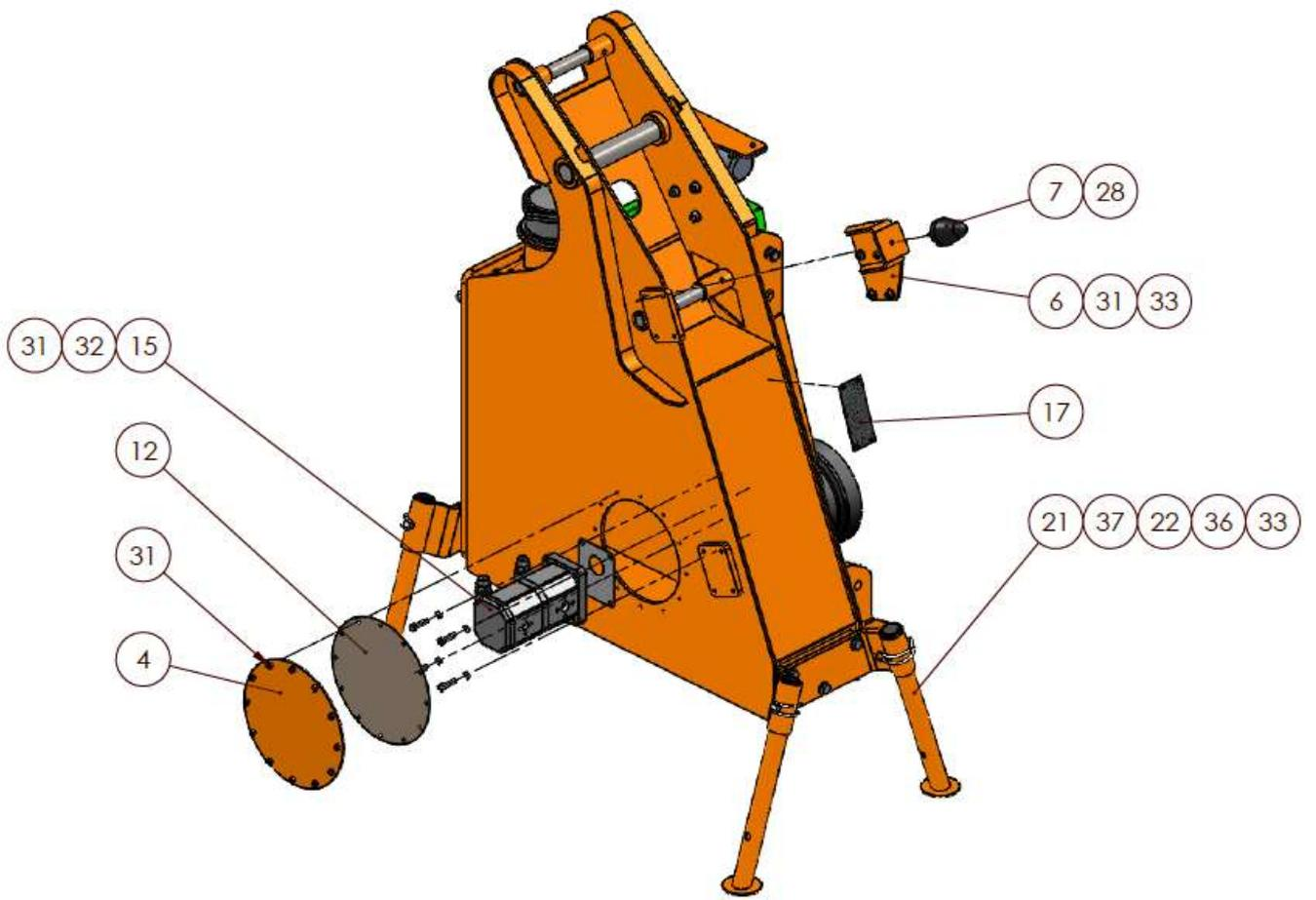

Rep	Reference	Description	Qty
1	TH.410.100	Tank type T	1
2	TH.440.170.02	Axis	1
3	TH.440.164.02	Axis	2
4	TH.440.105	Pump hatch	1
5	TH.440.168	Cover Cap	1
6	TH.440.T140	Stop for transport	1
7	21.512.502	Conical stop	1
8	TH.440.140	Counterweight	2
9	TH.440.148	Foot support	2
10	20.557.008	Filling cap	1
11	20.550.500	Return filter 3/4 OMTF75 BN-CF	1
12	25.500.010	Pump hatch seal	1
13	21.640.505	Multiplier gearbox 1/3,5	1
14	21.500.008	Paper gasket for pumpGr.2	1
15	21.630.701	Double pump 17+4cc Gr2	1
16	20.586.200	PTO shaft guard 21902 CE	1
17	25.550.102	European ratings plate	1
18	20.557.007	Liquid level with thermometer	1
19	TH.440.167	Lifting axis	2
20	TH.440.166	3rd point axis	1
21	TH.440.150	Support foot	4
22	GPN.320.GL34	Cap	4
23a	10.073.520	Hydraulic block 3 movements	1
23b	10.073.521	Hydraulic block 4 movements	
24	TH.410.717	Protective casing C06	1
25	TH.440.111	Support pressure filter	1
26	20.550.008	Pressure filter	1
27	21.570.409	Spring pin 8x35	6
28	21.026.505	Locknut H M10	9
29	TFIL.12.070	Threaded rod M12 - 070	5
30	21.087.412	Ø4x12 pop rivet	4
31	21.075.701	Allen screw M 8 x 20	58
32	21.031.502	Grower washer Ø8	4
33	21.036.529	Contact washer Ø8	41
34	21.576.102	Lynch pin clip de 8	2
35	21.576.101	Beta Pin D4	1
36	21.065.940	Hex head screw 12x20	3
37	21.570.569	Lynch pin clip	4
38	ELE.PUP.141	Calculator	1
39	TH.410.120	Folded sheet assembled	1
41	25.550.057	Briefcase assemblés	1

- **Arm 1**

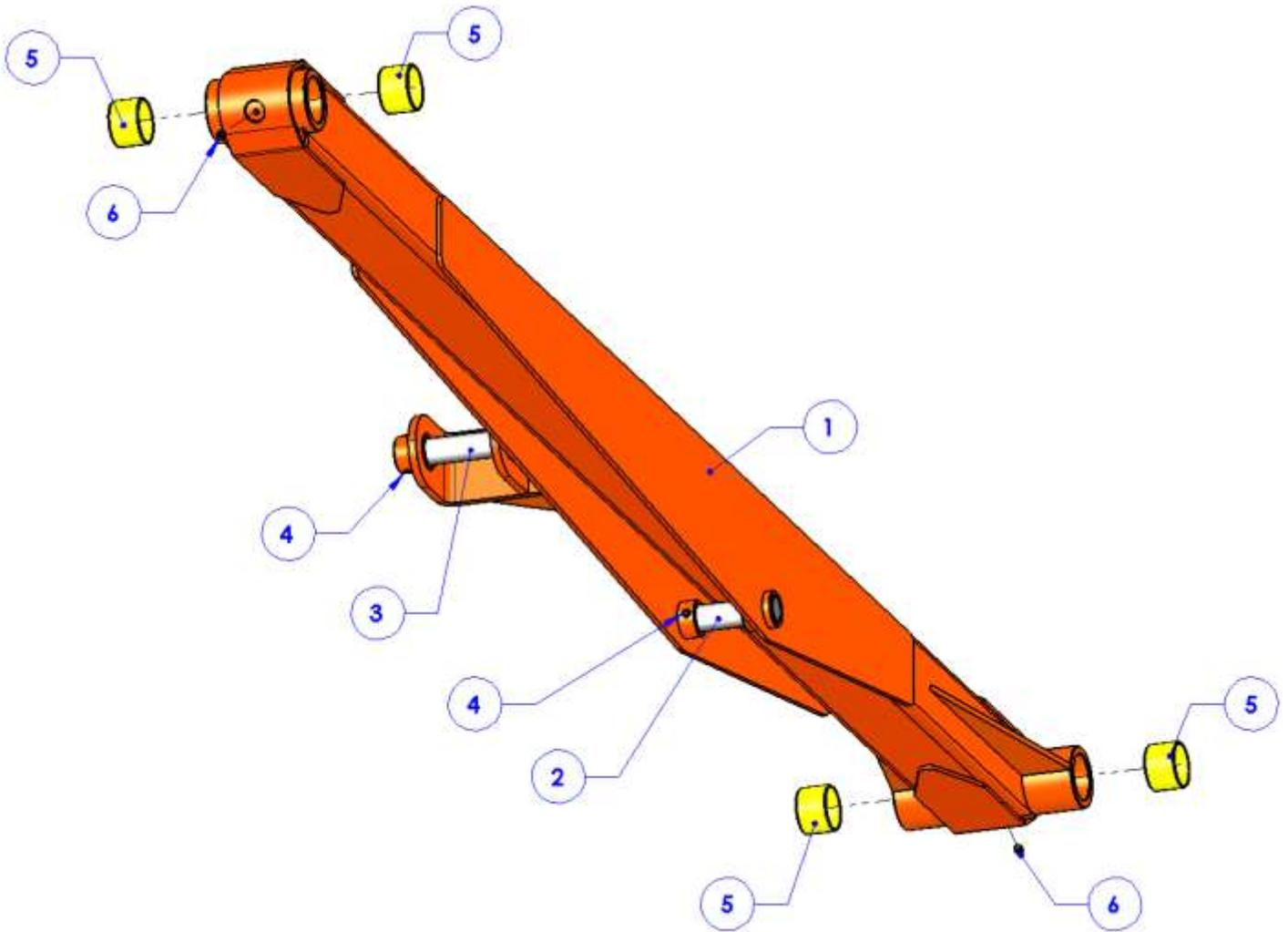

Rep	Reference	Description	Qty
1	TH.440.250	Arm 1	1
2	TH.440.224.02	Axis Cylinder head V01	1
3	TH.440.225.03	Axis Cylinder base V02	1
4	21.570.409	Spring pin Ø8x36	4
5	21.650.574	PAP Bushes 40x30 P10	4
6	21.886.002	Grease nipple M6x100	2

- **Strut**

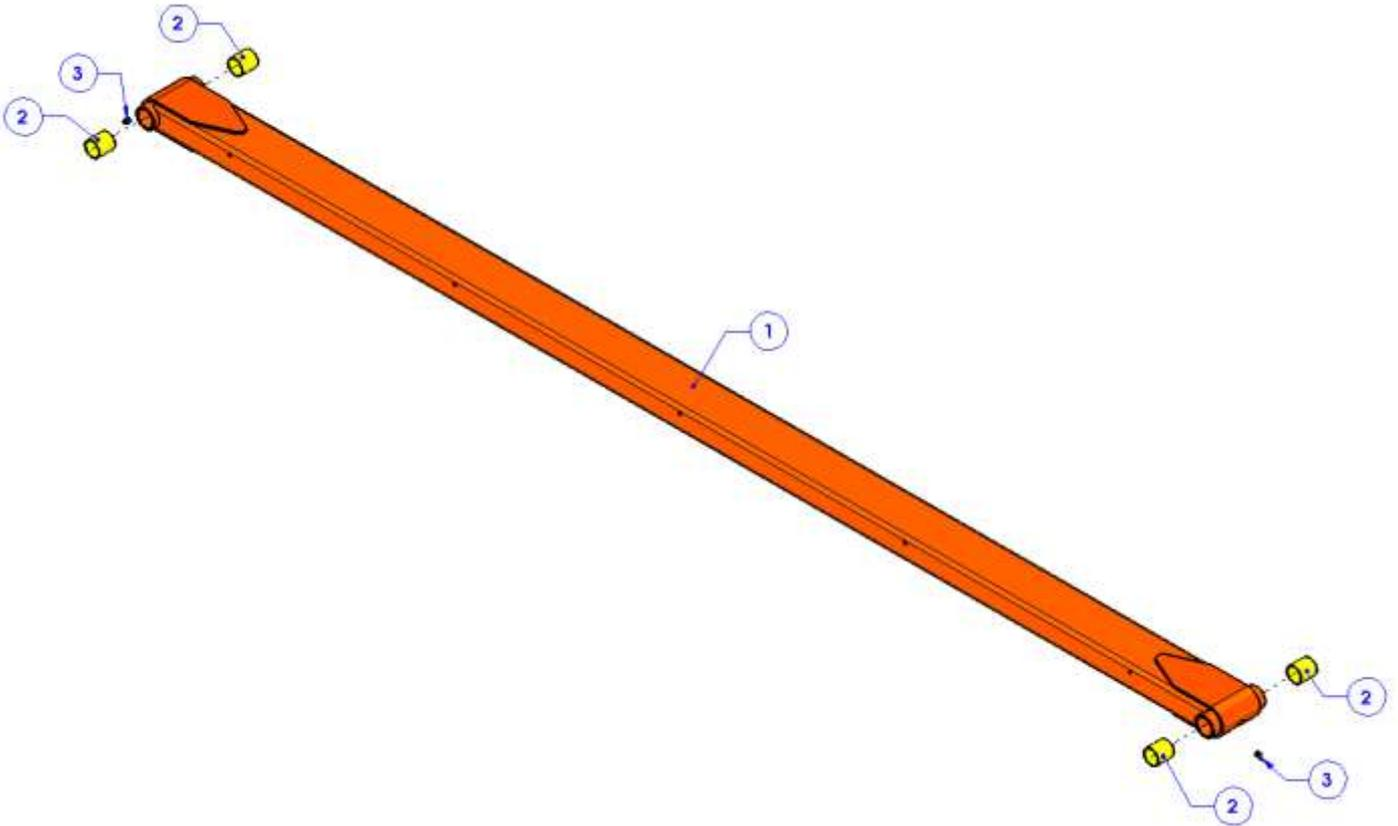

Rep	Reference	Description	Qty
1	TH.440.300	Strut	1
2	21.650.574	PAP Bushes 40x30 P10	4
3	21.886.002	Grease nipple M6x100	2

- Arm 2

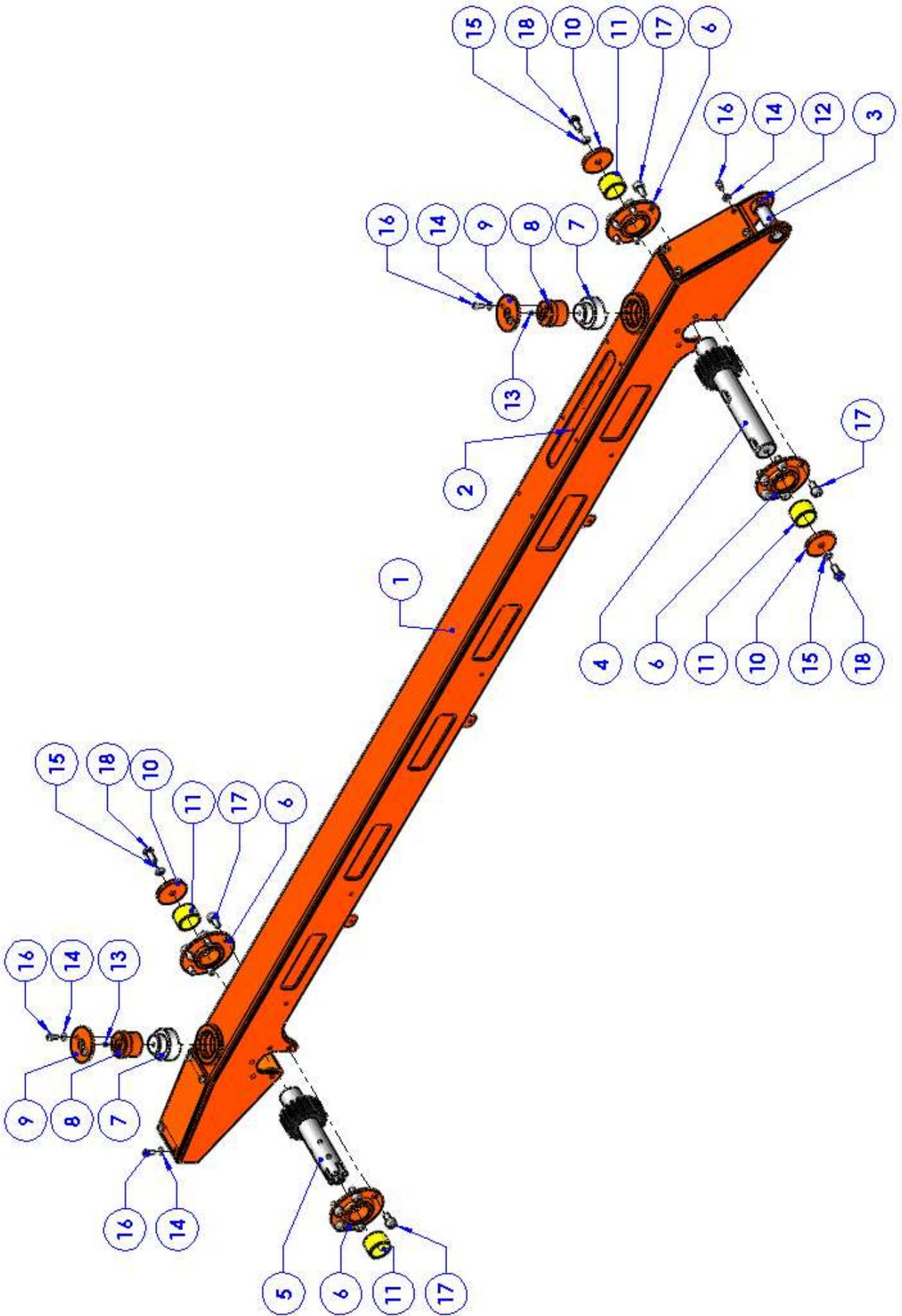

Rep	Reference	Description	Qty
1	TH.440.801	Arm 2	1
2	TH.440.555	Rack system	1
3	TH.440.563	Axis Cylinder head V02	1
4	TH.440.592	Axis pinion arm side 1	1
5	TH.441.593	Cutting bar side pinion	1
6	TH.440.568.02	Bearing arm 2	4
7	TH.440.569	Gliding piece Pressure rack	2
8	TH.440.565	Rack pressure screw	2
9	TH.440.570	Retaining washer	2
10	TH.440.571	Stop washer	3
11	21.650.574	PAP Bushes 40x30 P10	4
12	21.570.409	Spring pin Ø8x36	2
13	21.886.002	Grease nipple M6x100	2
14	21.036.524	Contact washer M6	12
15	21.036.526	Contact washer M10	3
16	21.075.602	Allen screw M6-16 ZN	12
17	21.075.802	Allen screw M10-20 ZN	20
18	21.067.801	Hex head screw M10-20 ZN	3
	TH.440.572	Spacer pinion	2

Assembly of the rack system inside the arm 2:

The assembly of this system is done using a template so that the cutter bar is oriented correctly.

**Warning: The offset of a tooth on the pinion on the arm 1 side can cause the collision between two parts.**

The arm 1 side sprocket is important for the correct operation of the hedge trimmer.  
The sprocket on the arm 2 side is important for the orientation of the cutter bar.

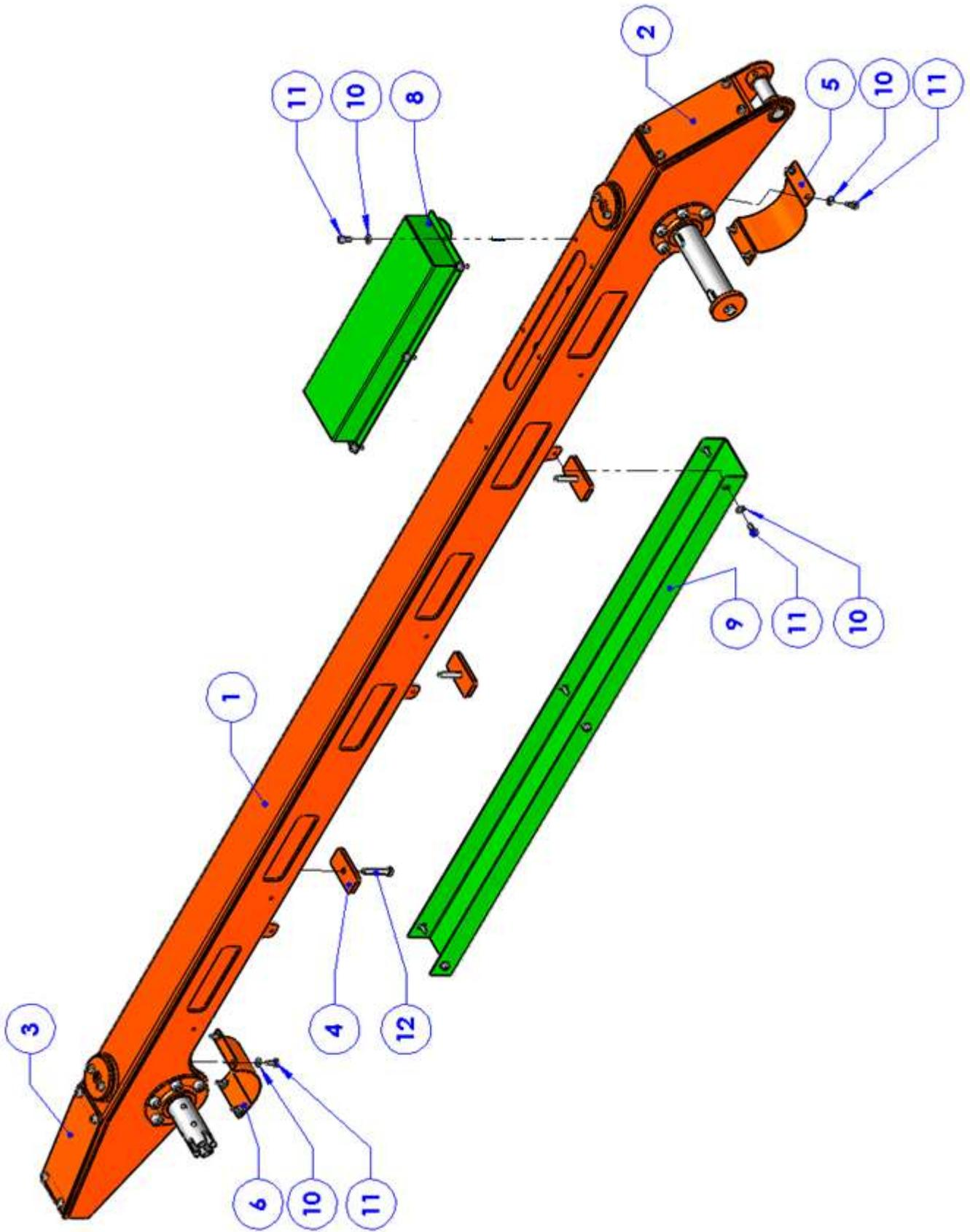

Rep	Reference	Description	Qty
1	TH.440.801	Arm 2	1
2	TH.440.512	Cover rack arm side	1
3	TH.440.513	Cover rack Saw Head side	1
4	TH.440.514	Flange	3
5	TH.440.720.02	Cover pinion arm side	1
6	TH.440.722.03	Cover pinion Saw Head side	1
8	TH.440.C02	Protective casing	1
9	TH.440.C01	Protective casing	1
10	21.036.524	Contact washer M6	19
11	21.075.602	Allen screw M6-16 ZN	19
12	21.067.706	Hex head screw M8-50 ZN	3

- **Cutter bar support**

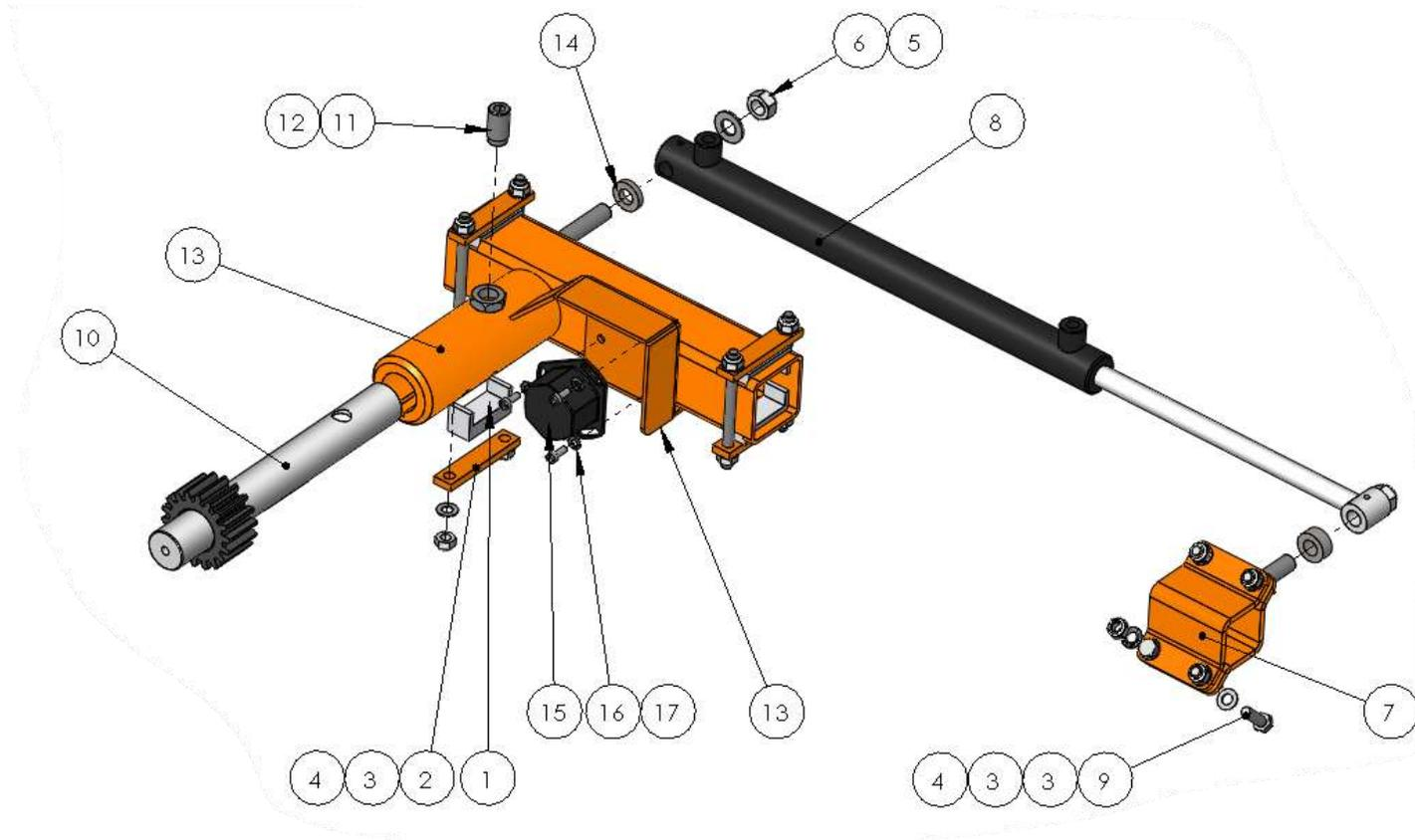

REP.	REFERENCE	DESCRIPTION	QTY
1	TH.K04.114	Gliding piece 114	4
2	TH.K02.115	Sheet 115	1
3	21.036.526	Contact washer Ø10	16
4	21.026.505	Locknut H M10	12
5	21.036.527	Contact washer Ø16	1
6	21.026.508	Locknut H M16	1
7	TH.K04.02.140	Cylinder head support Cutter bar offset	1
8	21.700.400/A	Cylinder 20X32 C0400	1
9	21.067.812	Vis H M10x35	4
10	TH.K04.03.593	Axis + pinion complete 593 – Saw Head side	1
11	TH.K0403.563	Special screw	1
12	21.029.106	Low nut M20x150 ZBJ	1
13	TH.410.650	Support of Saw Head	1
14	TH.K04.106	Spacer 106	3
15	ELE.PUP.250.03	Sensor COCO 360°	1
16	21.036.524	Contact washer Ø6	3
17	21.075.602	Allen screw M6x16	3



• **Saw Head 4420 – Machine-welded element**

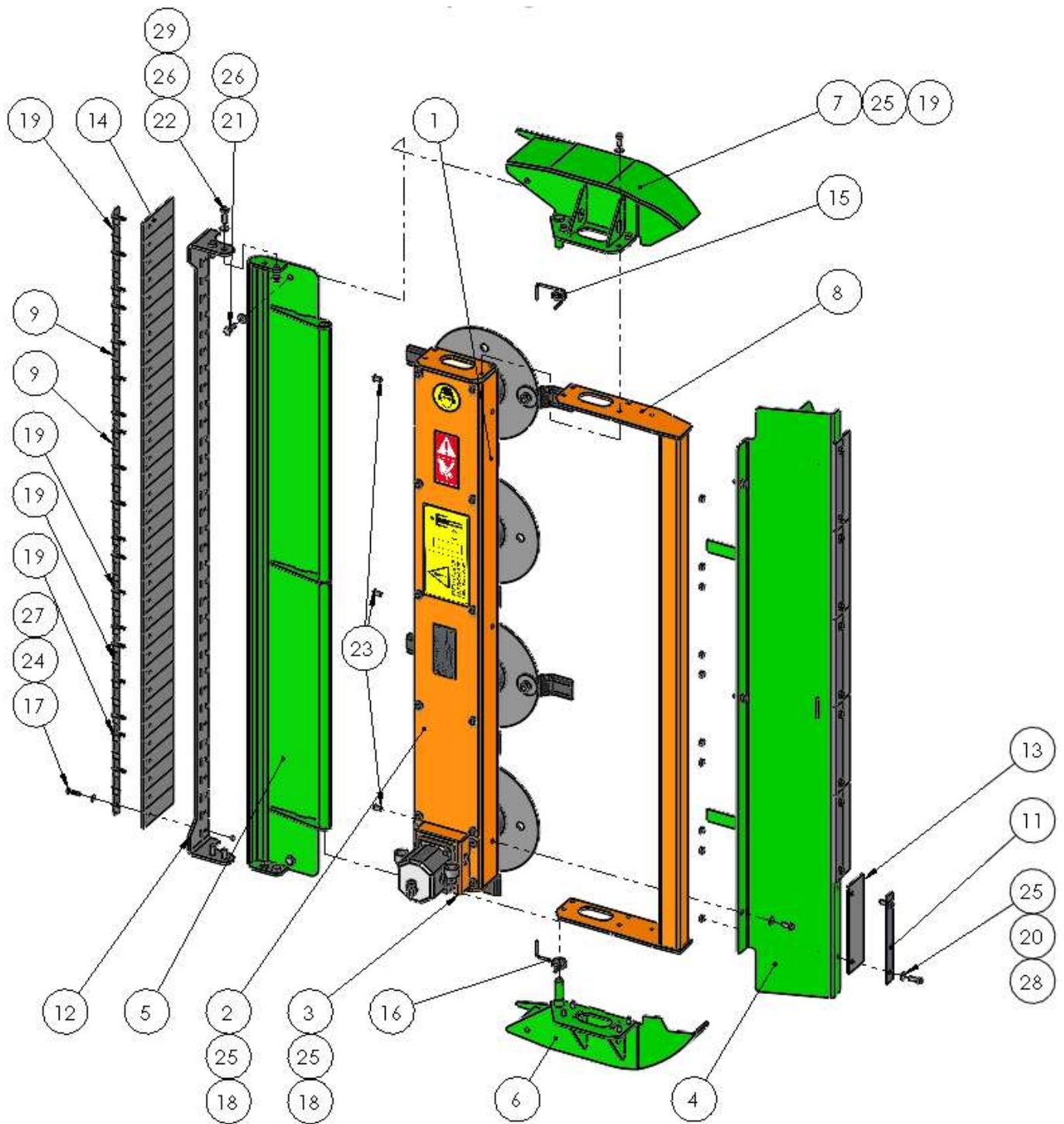

Rep	Reference	Description	Qty
1	04.010.100	Casing	1
2	04.010.600	Cover	1
3	03.010.200	Engine dome	1
4	04.010.700	Rear protective casing	1
5	04.010.400	Front protective casing	1
6	03.010.300	Bottom shoe	1
7	03.010.310	Top shoe	1
8	04.010.500	Support tube	1
	04.010.510	Removable support tube	1
	TH.541.TC58	Offset mounting plate for support tube	2
9	FB.004.362	Front holding plate for Rubber flap	2
19	FB.004.363	Front holding plate for Rubber flap	4
11	31.510.344	Rear holding plate for Rubber flap	6
12	04.010.451	Front support plate for rubber flap	1
13	31.510.343	Rubber flap 221x65x4	6
14	03.010.452	Rubber flap 130x45x4	34
15	FB.001.A03	Right side spring - D.296.360.0325	1
16	FB.001.A04	Left side spring - D.296.360.0325	1
17	21.075.607	Allen screw M 6 x 25 ZN	20
18	21.075.700	Allen screw M 8 x 16	14
19	21.075.701	Allen screw M 8 x 20	10
20	21.067.703	Hex head screw 8x25	12
21	21.067.802	Hex head screw 10x25	2
22	21.067.803	Hex head screw 10x30	4
23	21.074.603	TBHC M8x16	3
24	21.036.524	Contact washer Ø6	20
25	21.036.529	Contact washer Ø8	42
26	21.036.526	Contact washer Ø10	6
27	21.026.503	Locknut H M6	20
28	21.026.504	Locknut H M8	18
29	21.026.505	Locknut H M10	8

- **Saw Head 5420 – Machine-welded element**

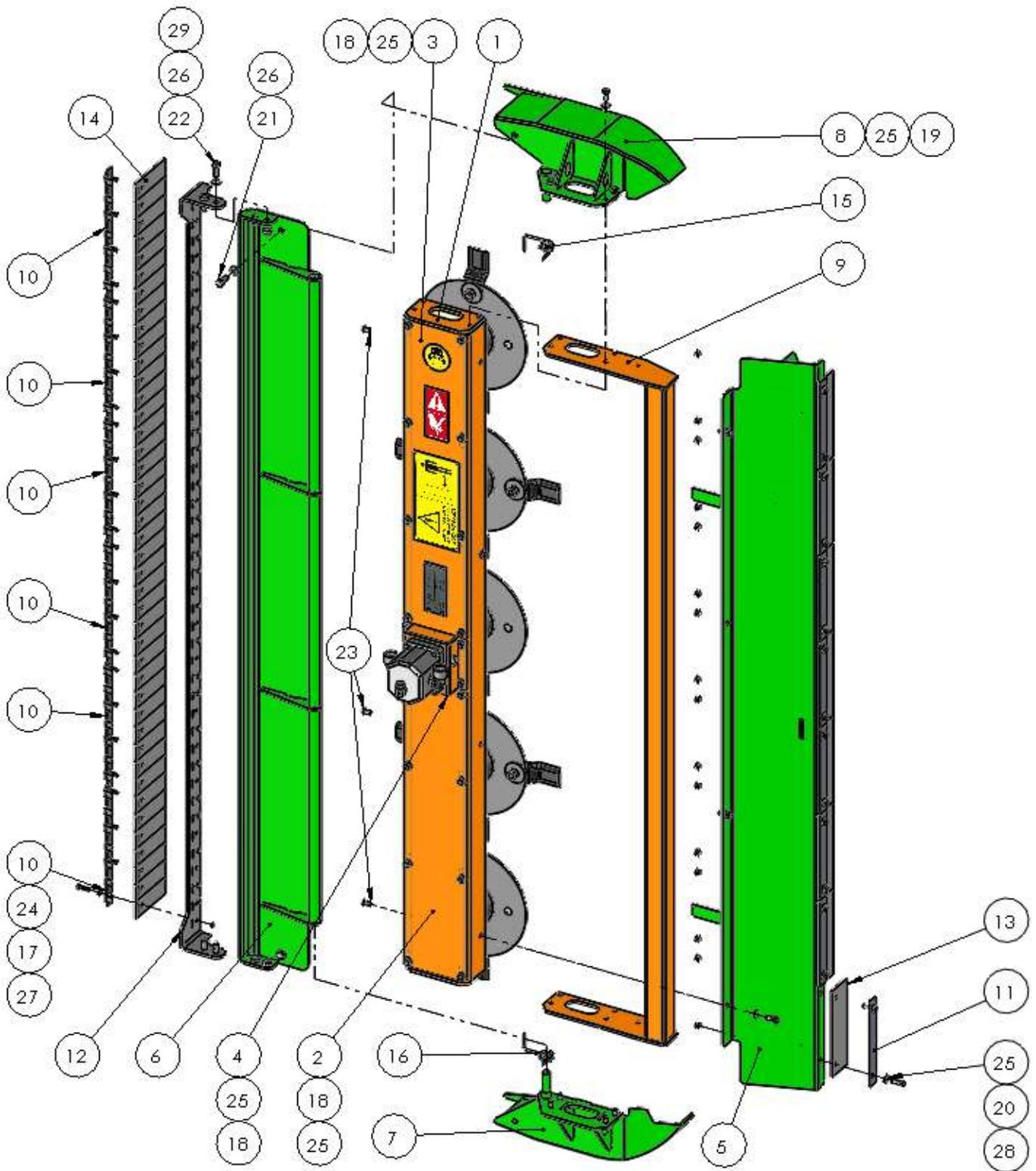

Rep	Reference	Description	Qty
1	05.010.100	Casing	1
2	05.010.601	Cover	1
3	03.010.600	Cover	1
4	03.010.200	Engine dome	1
5	05.010.700	Rear protective casing	1
6	05.010.400	Front protective casing	1
7	03.010.300	Bottom shoe	1
8	03.010.310	Top shoe	1
9	05.010.500	Support tube	1
	05.010.510	Removable support tube	1
	TH.541.TC58	Offset mounting plate for support tube	2
10	FB.004.362	Front holding plate for Rubber flap	6
11	31.510.344	Rear holding plate for Rubber flap	8
12	05.010.451	Front support plate for rubber flap	1
13	31.510.343	Rubber flap 221x65x4	8
14	03.010.452	Rubber flap 130x45x4	42
15	FB.001.A03	Right side spring - D.296.360.0325	1
16	FB.001.A04	Left side spring - D.296.360.0325	1
17	21.075.607	Allen screw M 6 x 25 ZN	24
18	21.075.700	Allen screw M 8 x 16	20
19	21.075.701	Allen screw M 8 x 20	11
20	21.067.703	Hex head screw 8x25	16
21	21.067.802	Hex head screw 10x25	2
22	21.067.803	Hex head screw 10x30	4
23	21.074.603	TBHC M8x16	4
24	21.036.524	Contact washer Ø6	24
25	21.036.529	Contact washer Ø8	47
26	21.036.526	Contact washer Ø10	6
27	21.026.503	Locknut H M6	24
28	21.026.504	Locknut H M8	16
29	21.026.505	Locknut H M10	4

- Bearing assembly

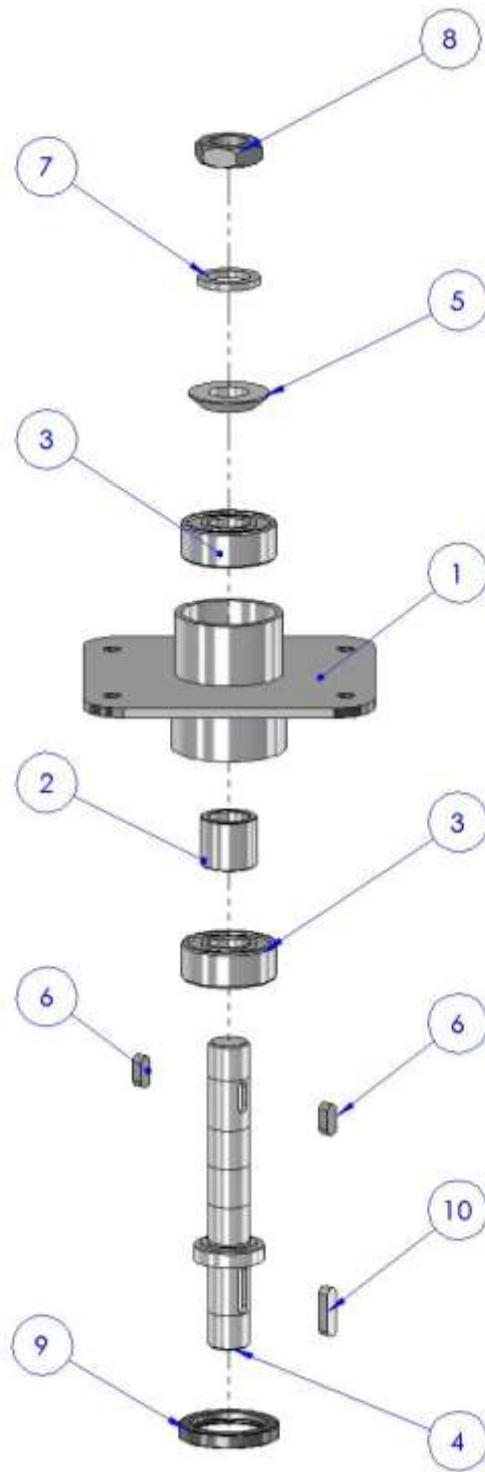

REP.	REFERENCE	DESCRIPTION	QTY
1	GA.06.P1.243	Plate	1
2	TH.440.656	Lubrication spacer	1
3	21.670.801	Bearing 2204 EE G15	2
4	TH.440.681	Shaft	1
5	TH.440.697	Pulley spacer	1
6	TH.440.660	Key 6 x 6x 16	2
7	21.046.500	NORD LOCK NL 21 washer	1
8	21.029.100	Low nut M20x100 ZBJ	1
9	TH.440.663	Leap Seal 35x50x7	1
10	TH.440.659	Key 6x6x25	1

- **Bearing and plates assembly on the Casing**

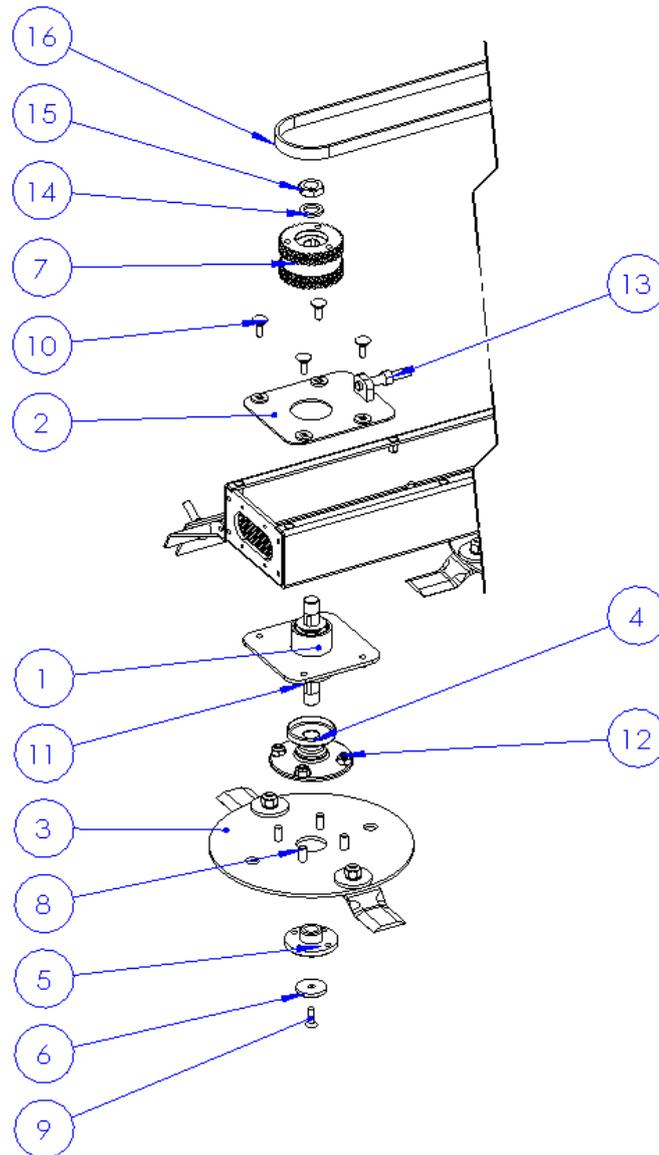

REP.	REFERENCE	DESCRIPTION	QTY
1	GA.06.P1.240	Bearing N420	1
2	GA.06.P1.225	Tension plate	1
3	TH.440.026	Complete flail blade	1
4	TH.440.651	Counter flange for plate	1
5	TH.440.654	Lock nut	1
6	TH.440.657	Safety washer	1
7	TH.443.692	Toothed pulley Eagle 34 teeth	1
8	21.075.803	Allen screw M 10 x 25	4
9	21.080.702	Hex socket countersunk screw 8x25	1
10	21.015.710	Bolt 8x25	4
11	21.026.504	Locknut H M8	4
12	21.026.505	Locknut H M10	4
13	21.020.505	Nut M12	1
14	21.046.500	NORD LOCK NL 21 washer	1
15	21.029.100	Low nut M20x100 ZBJ	1
16	21.750.522	Chevron belt	1

- Coupling assembly- Gear motor

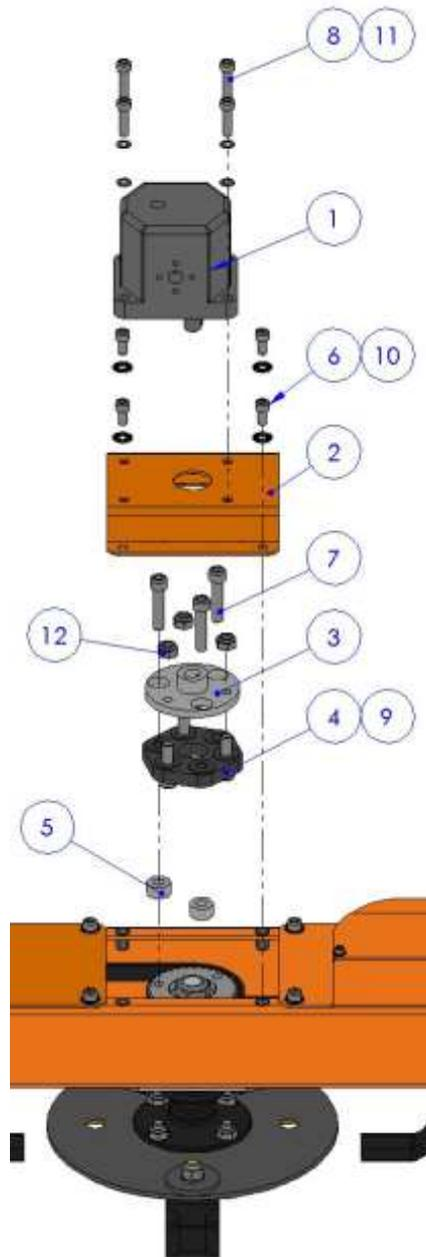

REP.	REFERENCE	DESCRIPTION	QTY
1	21.620.800	Motor SEM2-8cc	1
2	2.02.0420.101	Engine support	1
3	TH.440.653	Half coupling 653	1
4	21.667.501	Flector	1
5	TH.440.696	Coupling spacer	3
6	21.075.700	Allen screw M 8 x 16	4
7	21.075.809	Allen screw M 10 x 45	3
8	21.075.703	Allen screw M 8 x 30	3
9	21.075.805	Allen screw M 10 x 35	3
10	21.036.529	Contact washer Ø8	4
11	21.031.502	Grower washer Ø8	4
12	21.026.505	Locknut H M10	3

- Equiped gear motor

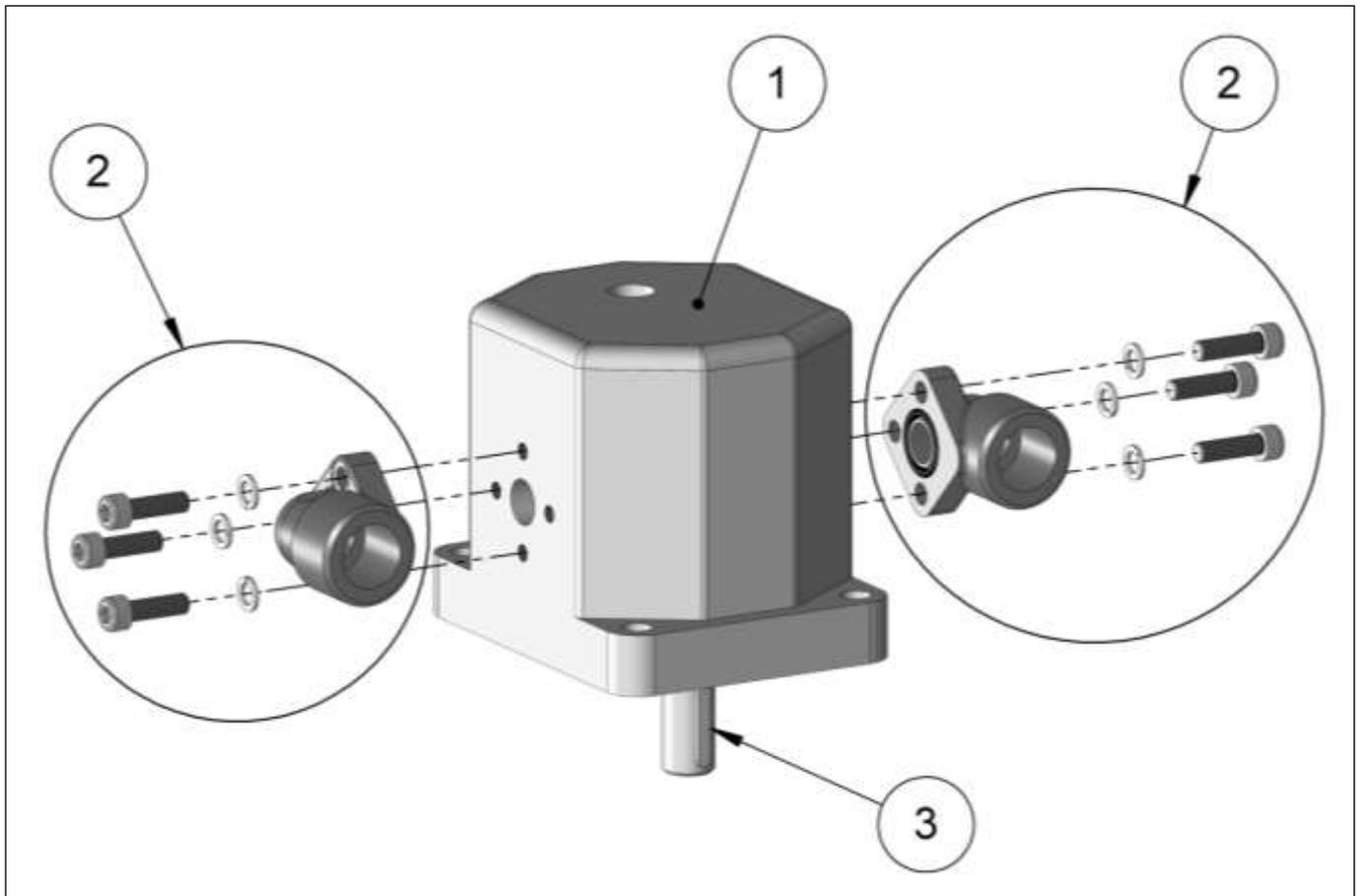

Rep	Reference	Description	Qty
1	21.620.801	Gear motor Gr.2 6 cm <sup>3</sup>	1
	21.620.800	Gear motor Gr.2 8 cm <sup>3</sup>	
	21.620.803	Gear motor Gr.2 11 cm <sup>3</sup>	
	21.620.806	Gear motor Gr.2 14 cm <sup>3</sup>	
	21.620.805	Gear motor Gr.2 17 cm <sup>3</sup>	
2	21.640.511	BCAI 30 1/2 flange (for 6, 8 and 11 cm <sup>3</sup> )	2
	21.640.512	BCAI 40 1/2 flange (for 14 cm <sup>3</sup> )	
	21.640.510	BCAI 40 3/4 flange (for 17 cm <sup>3</sup> )	
3	21.560.706	Motor shaft key	1

- **Tools - Mounting and removing a flail plate**

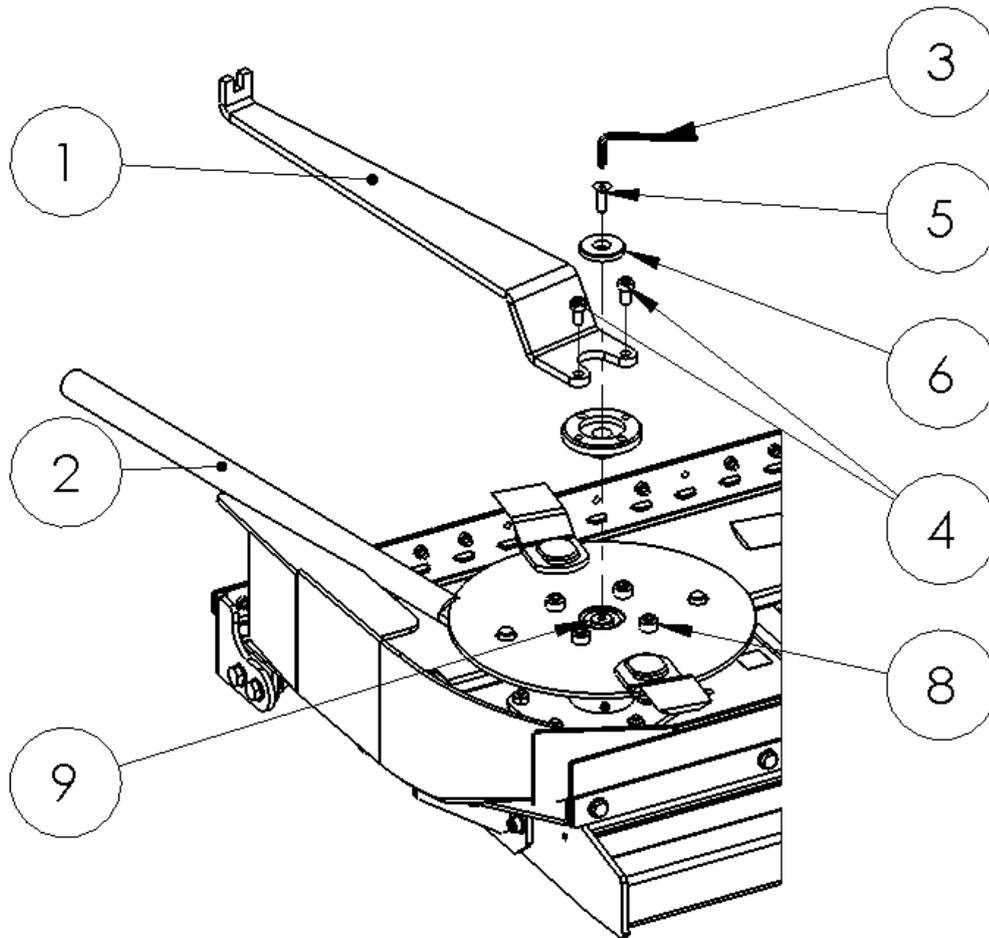

Rep	Reference	Description	Qty
1	TH.440.918	Tightening wrench	1
2	TH.440.985	Holding wrench	1
3	30.700.750	Allen wrench 5	1
4	21.075.700	Allen screw M 8 x 16	2

- Flail blades assembly on a single plate 2 knives

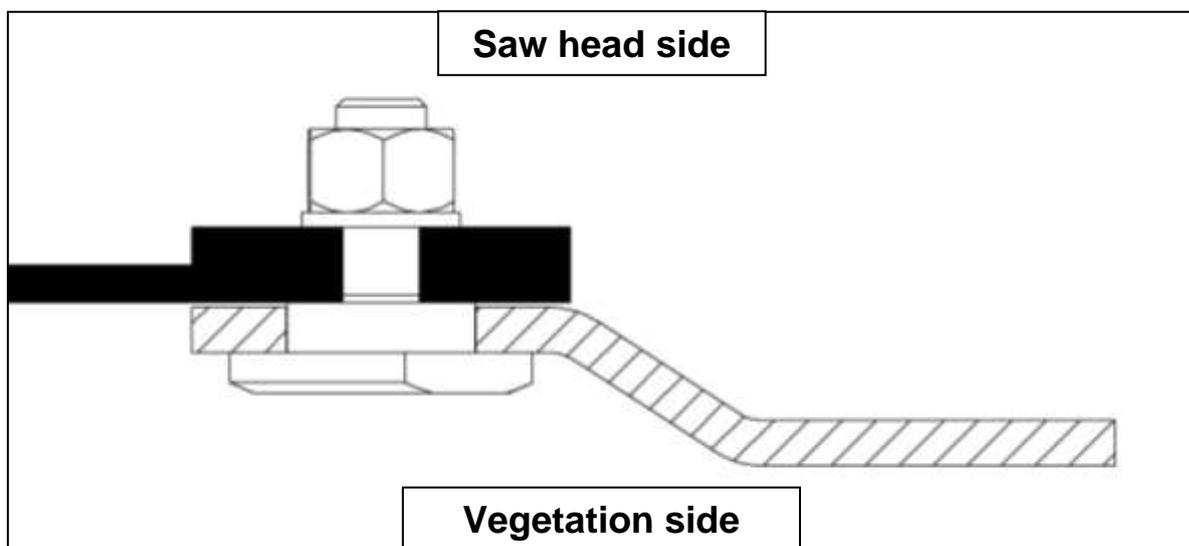
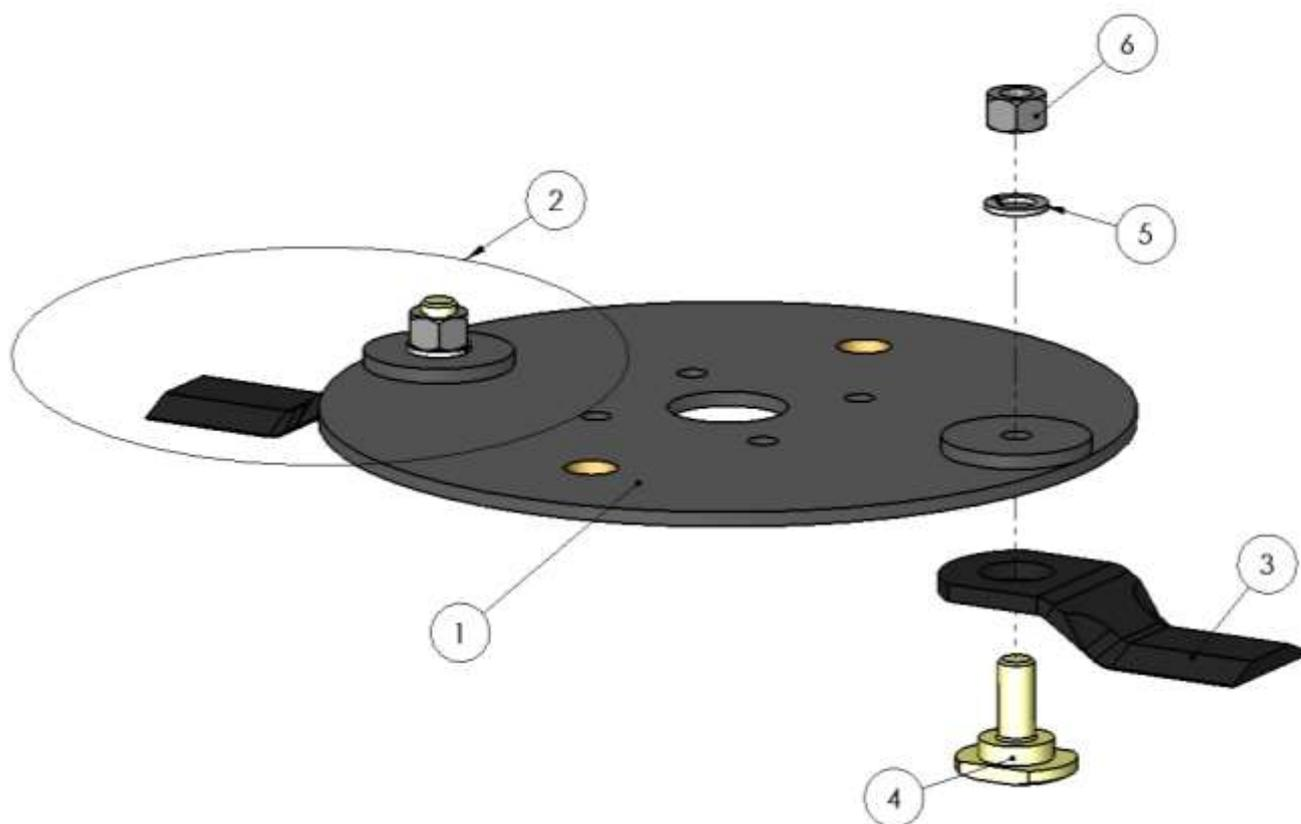

Rep	Reference	Description	Qty
-	TH.440.026	Complete flail blade	1
1	TH.440.X61	Unequipped single disc	1
2	30.702.457	Kit of 2 knives with bolts	1
3	-	Dual sided, dual angle angled knife,	2
4	-	Knife bolt	2
5	-	Hex head nut UNF 1/2" HU 20 ZBJ	2
6	-	Grower washer 1/2"	2

- Saw blade kit

### Large offset landing blade assembly

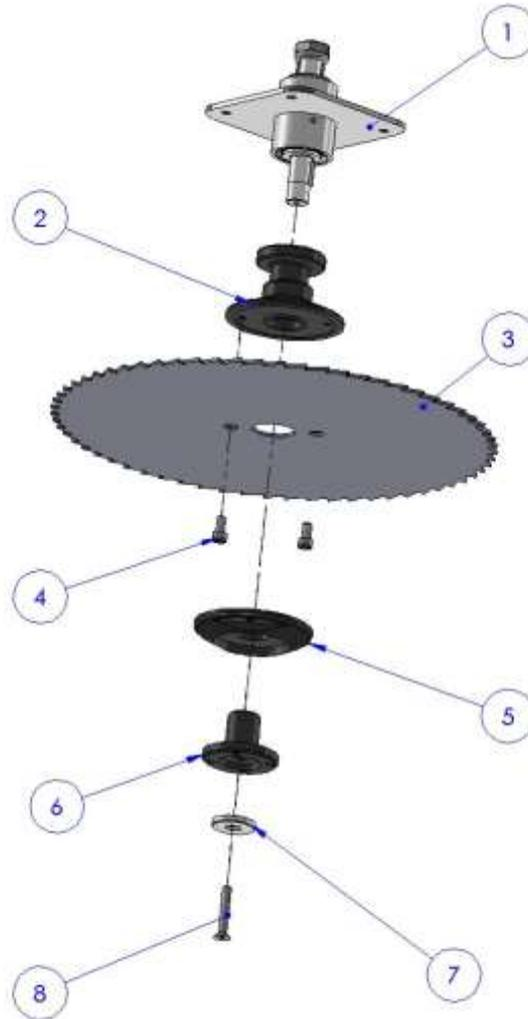

REP.	REFERENCE	DESCRIPTION	QTY
1	GA.01.P1.240	Bearing	1
2	TH.440.913	Long offset Counter-flange	1
3	35.600.605	Saw 420- 64 teeth -Al 40- ép 3	1
4	21.075.700	Allen screw M 8 x 16	2
5	TH.440.914	Clamping flange	1
6	TH.440.916	Long offset Lock nut	1
7	TH.440.657	Safety washer	1
8	21.080.705	Hex socket countersunk screw 8x50	1

## Short offset landing blade assembly

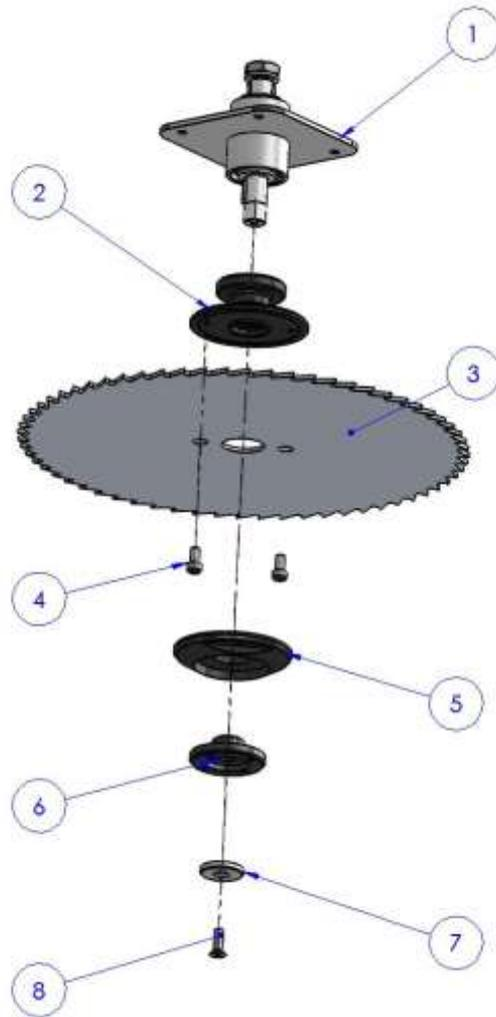

REP.	REFERENCE	DESCRIPTION	QTY
1	GA.01.P1.240	Bearing	1
2	TH.440.912	Short offset Counter-flange	1
3	35.600.605	Saw 420- 64 teeth -Al 40- ép 3	1
4	21.075.700	Allen screw M 8 x 16	2
5	TH.440.914	Clamping flange	1
6	TH.440.654	Lock nut	1
7	TH.440.657	Safety washer	1
8	21.080.702	Hex socket countersunk screw 8x25	1

- **Tools**

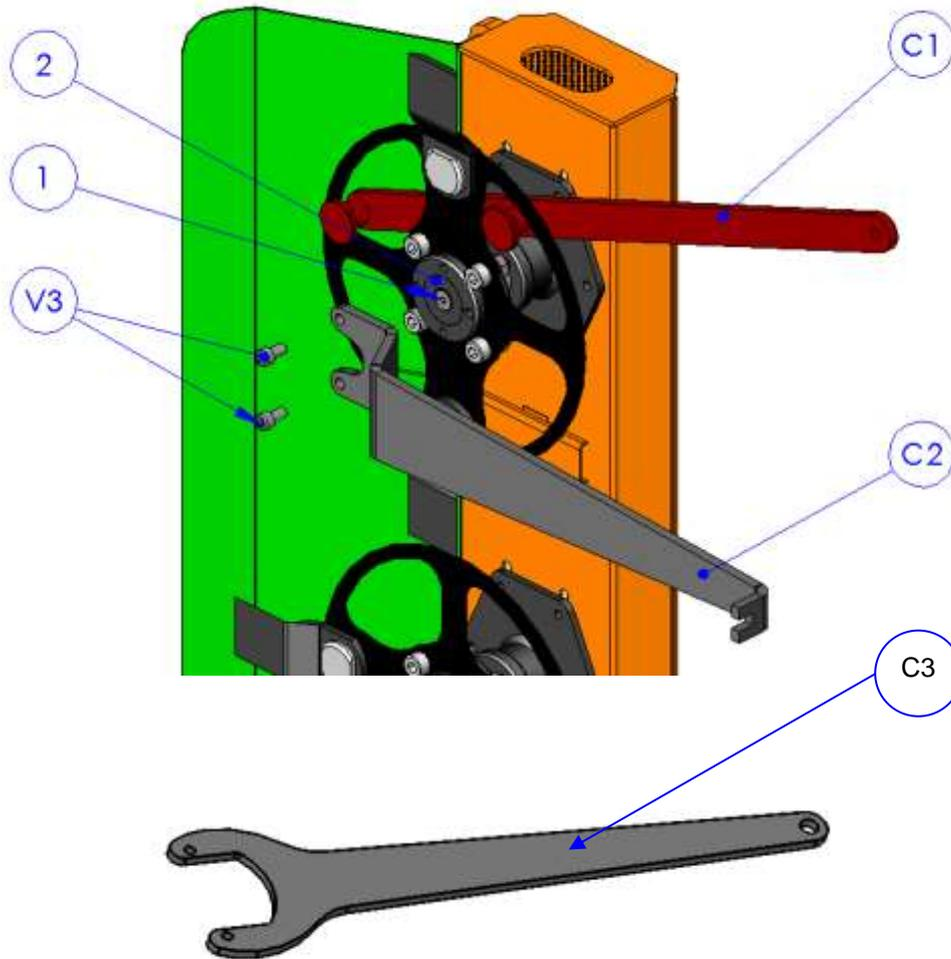

REFERENCE	DESCRIPTION	QTY	ITEM
<b>442.05.01</b>	<b>Complete tools kit pour Saw Head 420</b>		
TH.440.980	Holding wrench	1	C1
TH.440.918	Tightening wrench	1	C2
30.700.750	Allen key 5 (for Safety screw)	1	
21.075.700	Allen screw 8x16	2	V3
TH.440.917.02	Flange Locking Key for Blades	1	C3

- **Safety stickers.**

Rep	Reference	Description	Qty
	<b>TH.440.SE</b>	<b>Safety adhesives kit</b>	
E1	25.550.002	Keep a safe distance	7
E2	25.550.017	Wear helmet and glasses	2
E3	25.550.018	Anchor point for handling	1
E4	25.550.019	Cut Hazard: Saw blade	2
E5	25.550.035	Cut hazard: knife	2
E6	25.550.010	Lubrication point	



E1



E2



E3



E4



E5



E6







**Z.I. du Chail – 17800 PONS - Tél. 05.46.96.25.50 – email : [coupeco@coupeco.com](mailto:coupeco@coupeco.com)  
S.A.S. au capital de 100 000 € - R.C.S. SAINTES B 401 895 883 - SIRET 401 895 883 0023 - Code A.P.E. 285 D**