

Publication 334
May 2000 (Issue2 Feb. 2004)
Part No. 41486.43

1.5M MULTICUT FLAILHEAD

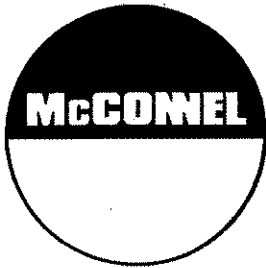

Operation & Parts Manual

1.5M 54HP with Tri-Mount and Metric Bolts
1.5M 65HP with Tri-Mount and Metric Bolts



McCONEl

READ THE BOOK FIRST

It might save hours and pounds later !

When ordering spare parts always quote

- ***The Machine Type***
- ***The Machine Serial Number***
- ***The Part Number***

Factory re-built service exchange units of the major hydraulic components are available from your Dealer

NOISE

The equivalent daily personal noise exposure from this machine, measured at the operators' ear, is within the range 78 – 85 DB.

These figures apply to a normal distribution of use where the noise fluctuates between zero and maximum. The figures assume that the machine is fitted to a tractor with a quiet cab with the windows closed in a generally open environment. We recommend that the windows are kept closed.

With the cab rear window open the equivalent daily personal noise exposure will increase to a figure within the range 82 – 88 DB.

At equivalent daily noise exposure levels of between 85 and 90 DB, ear protection is recommended, it should be used if any window is left open.

EC DECLARATION OF CONFORMITY
Conforming to EEC Directive 89/392/EEC

We,

McCONNEL LIMITED, Temeside Works, Ludlow,
Shropshire SY8 1JL.

declare under our sole responsibility that

the product (type) *Hydraulic Arm Mounted Flailhead*

Product Code *F112*

Serial No. & Date Type

Manufactured by the above Company/*

*(*insert business name and full address if not stated above)*

complies with the required provisions of the Directive 89/392/EEC,
and AMD 91/368/EEC, AMD 93/44/EEC, AMD 93/68/EEC and
conforms with European Norm. BS EN 292.

Part 1:1991 Safety of Machinery – Terminology, methodology.
Part 2:1991 Safety of Machinery – Technical Specifications.

and other national standards associated with its design and
construction as listed in the Technical File.

Signed *John Frank*

on behalf of McCONNEL LIMITED

Responsible Person

Status *Chief Engineer*

Date *February 2004*

GENERAL INFORMATION

Read this manual before fitting or operating the machine. Whenever any doubt exists contact your dealer or the McConnell Service Department for assistance.

Use only McConnell spare parts on McConnell equipment and machines.

DEFINITIONS

The following definitions apply throughout this manual:

WARNING

An operating procedure, technique etc., which can result in personal injury or loss of life if not observed carefully.

CAUTION

An operating procedure, technique etc., which can result in the damage of either machine or equipment if not observed carefully.

NOTE

An operating procedure, technique etc., which is considered essential to emphasise.

Left and Right-Hand

This term is applicable to the machine when fitted to the tractor and viewed from the rear. This also applies to tractor references.

Record the serial number of your machine on this page and always quote this number when ordering spares. Whenever information concerning the machine is requested remember to also state the type of tractor to which it is fitted.	
MACHINE SERIAL NUMBER	INSTALLATION DATE
MODEL DETAILS	
DEALERS NAME	
DEALERS TELEPHONE NUMBER	

OPERATION

MATERIAL THICKNESS CUTTING LIMITATIONS

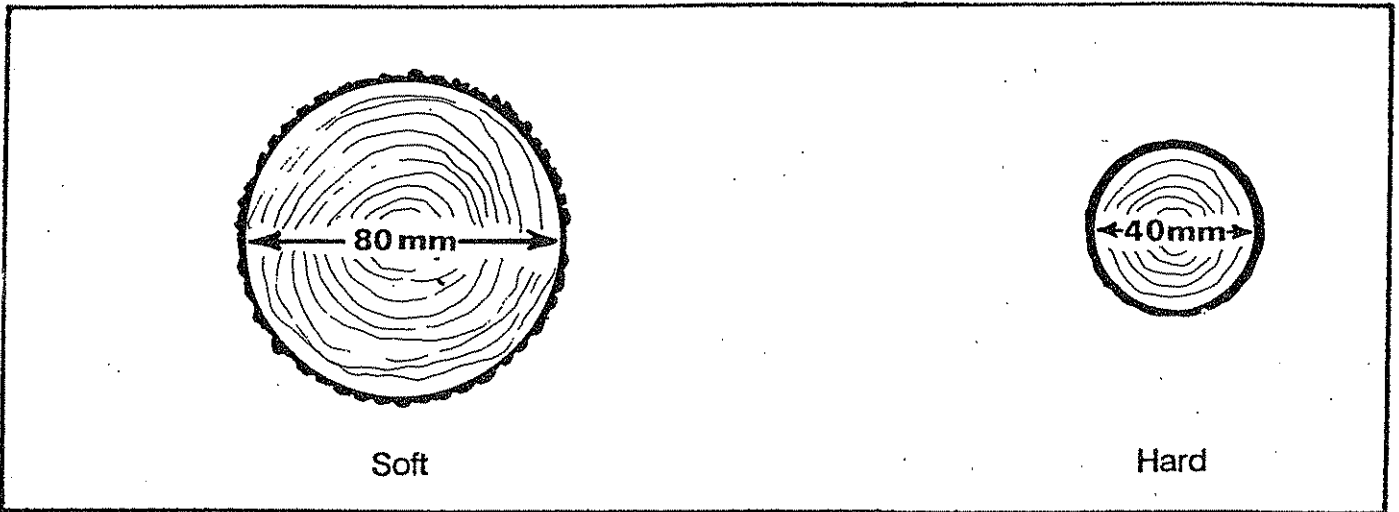

ROLLER POSITION

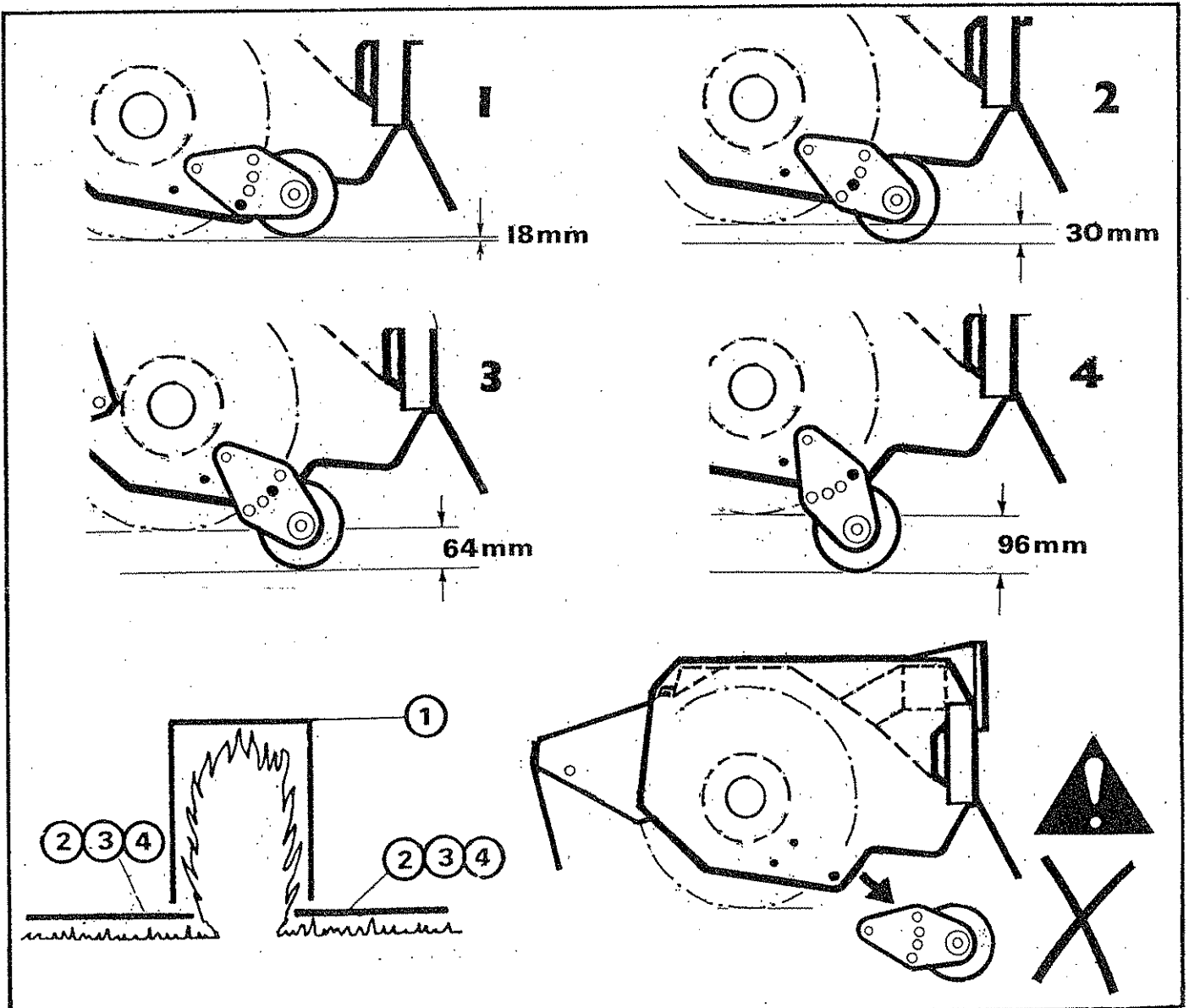

FLAILHEAD ARRANGEMENT

MOWING

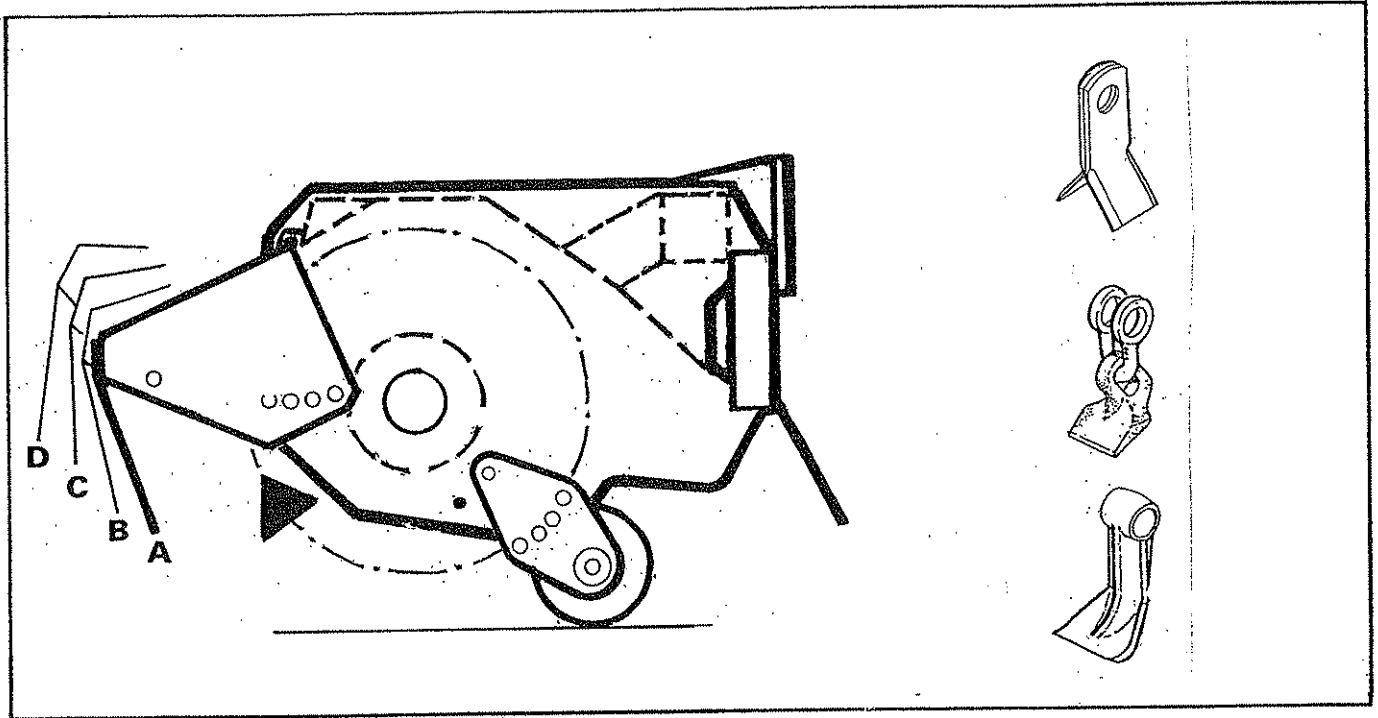

When mowing the rotor must always cut with an upwards rotation.

When mowing the roller must always be set below the level of the skid or the rotor if skids are not fitted i.e. in positions 2 - 4.

The front hood has four adjustment positions for height. The lowest possible position which allows the material to be cut to enter the head should always be used.

WARNING

Raising the front hood increases the possibility of debris escaping. Never operate the machine with the front hood set any higher than is absolutely necessary.

WARNING

Do not remove any guarding under any circumstance during operation.

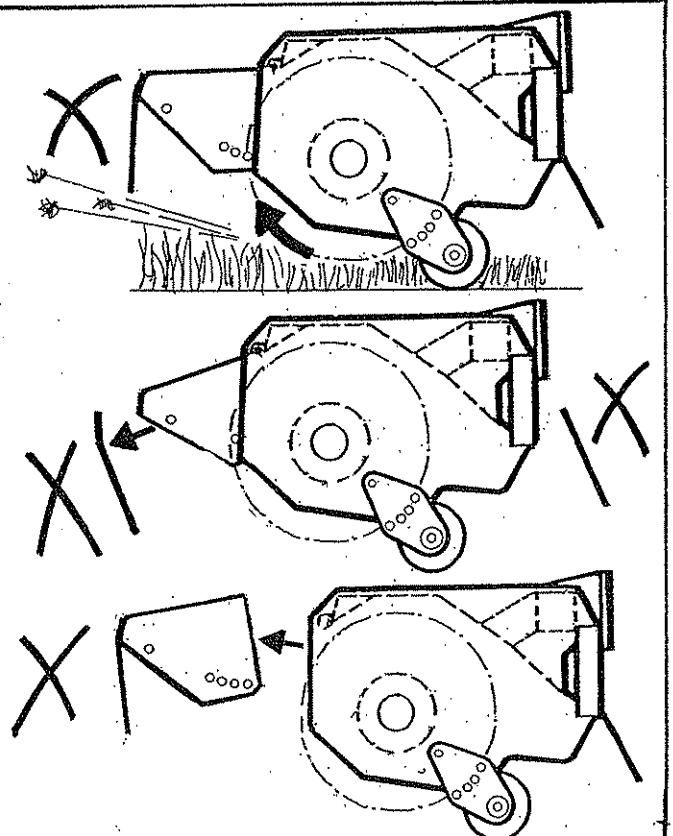
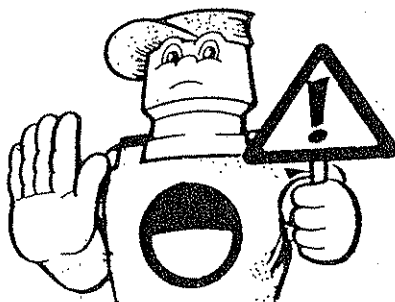

HEDGE CUTTING - Average working conditions.

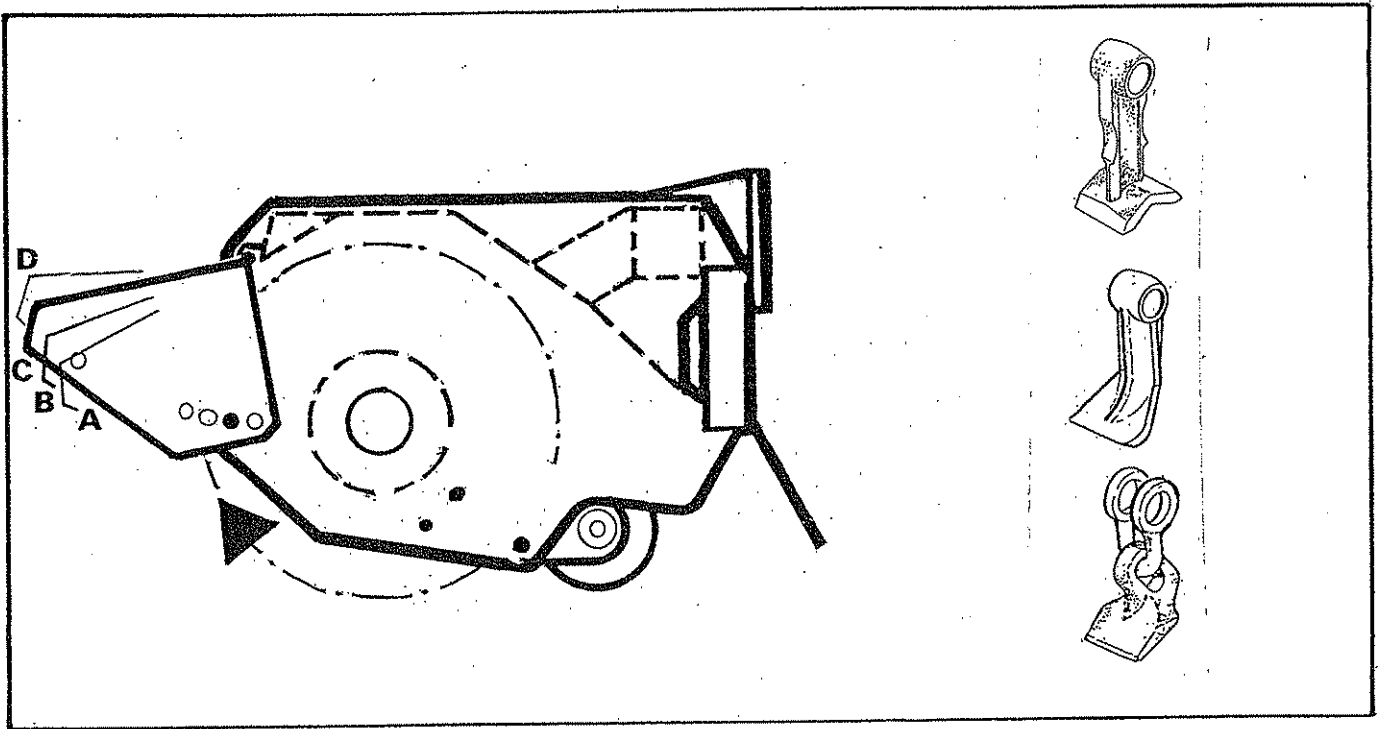

For the best finish the rotor should cut with an upwards rotation.

The roller should be set slightly above the rotor i.e. in position 1.

On universal heads the front rubber flaps and skids if fitted, may be removed to aid the entry of the material to be cut into the flail head.

The front hood has four adjustment positions for height. The lowest position which allows the material to be cut to enter the flail head should always be used.

WARNING

Raising the front hood increases the possibility of debris escaping. Never operate the machine with the front hood set any higher than is absolutely necessary.

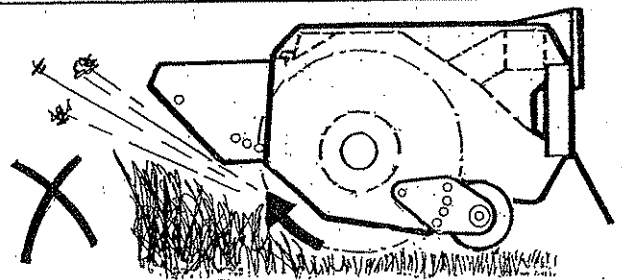

WARNING

Do not remove any guarding under any circumstance during operation.

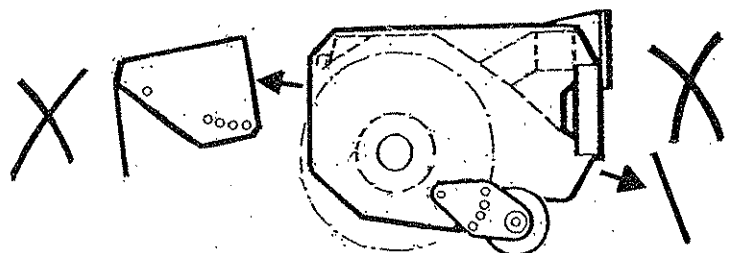
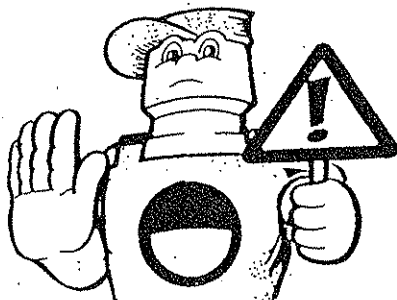

HEDGE CUTTING - Heavy duty working conditions

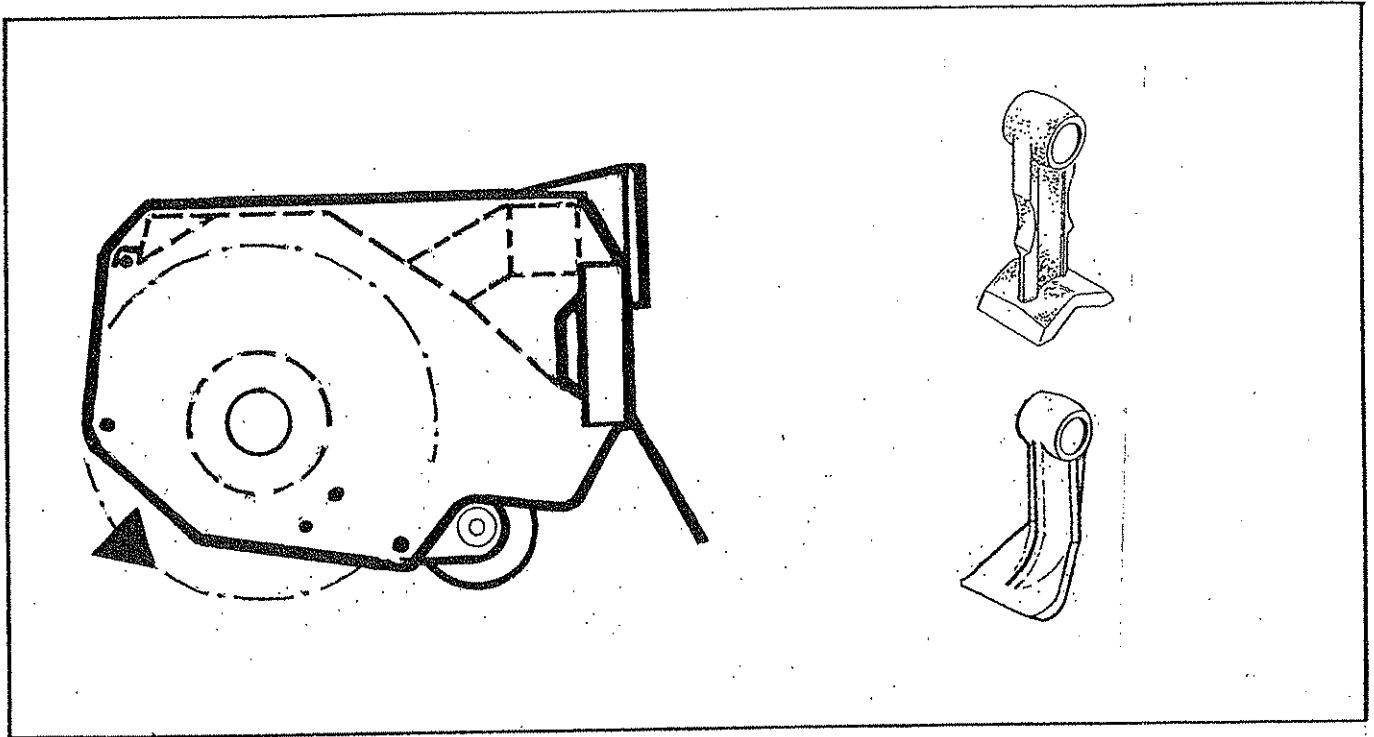

Where the size of the material to be cut makes it necessary for the front hood to be removed to allow the rotor to cut, the rotor must always cut with a downwards rotation.

This will result in a poorer finish and require more power than when cutting upwards.

The roller should be set slightly above the rotor i.e. in position 1

WARNING

Do not remove any guarding under any circumstance during operation.

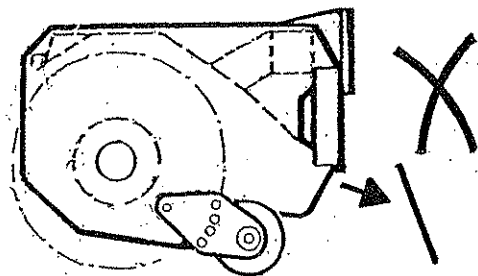
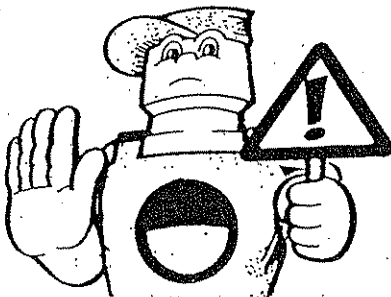

MAINTENANCE

FLAILHEAD

Frequently inspect the rotor assembly for damaged or missing flails.

Do not attempt to run the rotor with flails missing. Im-balance will cause severe vibration and can rapidly damage the rotor shaft bearings. As an emergency measure if a flail is broken off or lost, remove another on the opposite side of the rotor to retain balance. Always replace flails in opposite pairs and never match up a new flail with a re-sharpened one which will of course be lighter.

Blunt flails absorb a lot of power and leave an untidy finish to the work. They should be sharpened on a grindstone or with a portable grinder periodically.

Wear protective gear when sharpening flails.

Check:- All bolts are tight and that the torque figures are correct for the specific locations shown below.

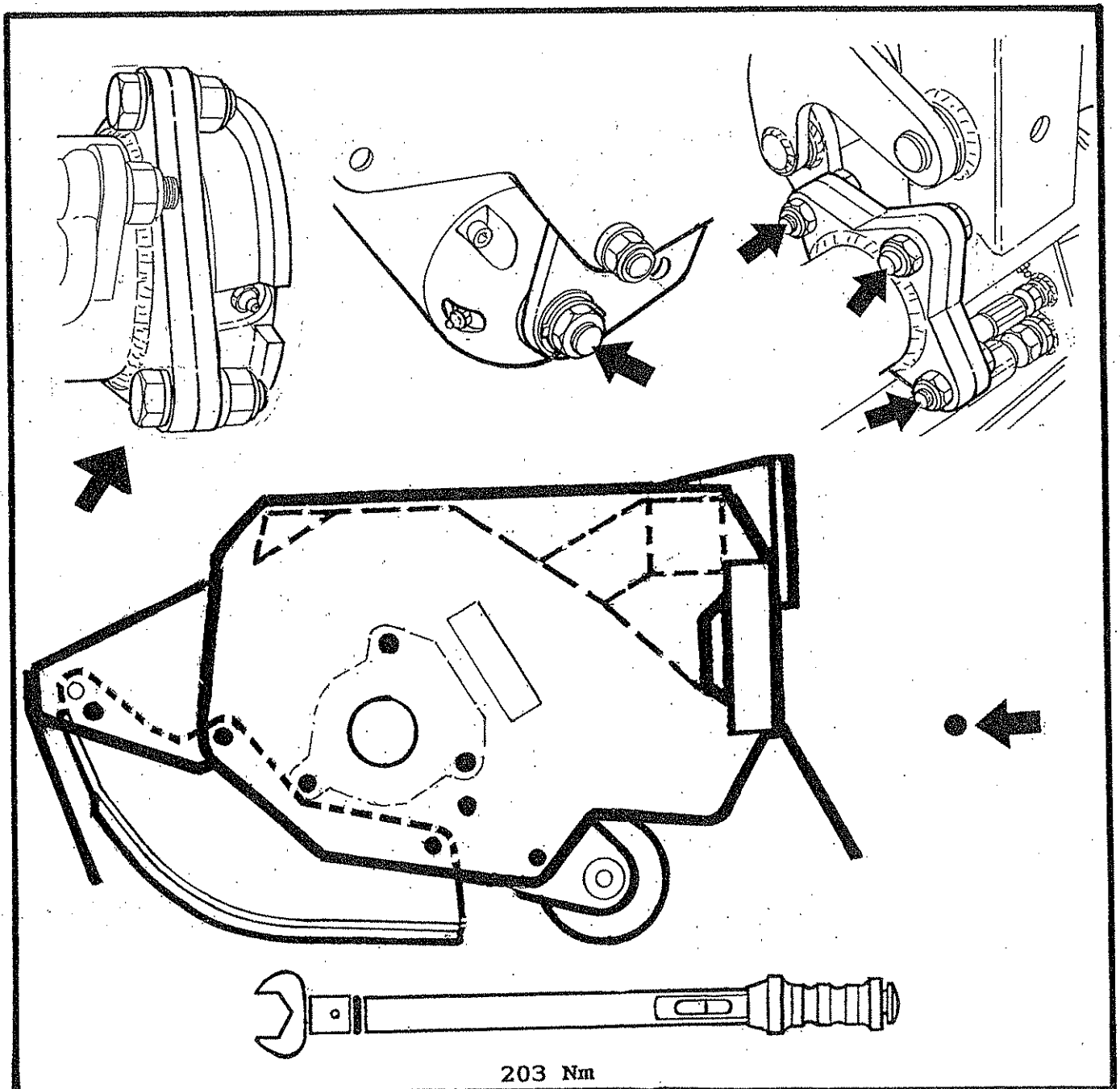

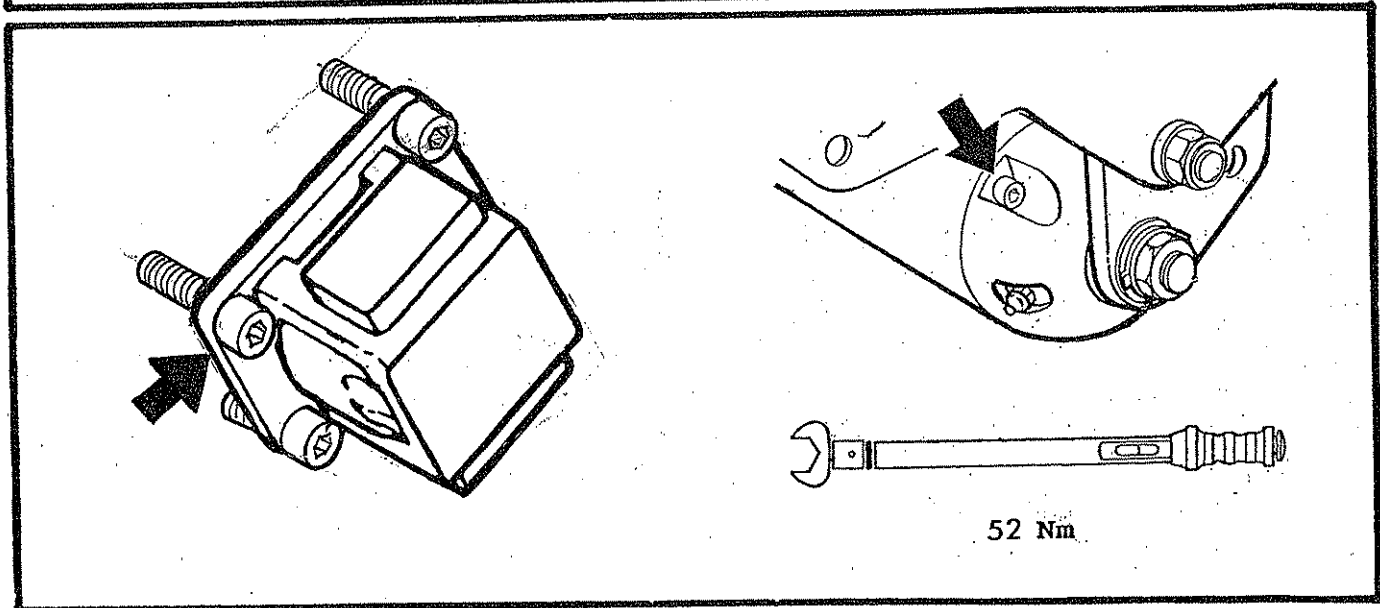
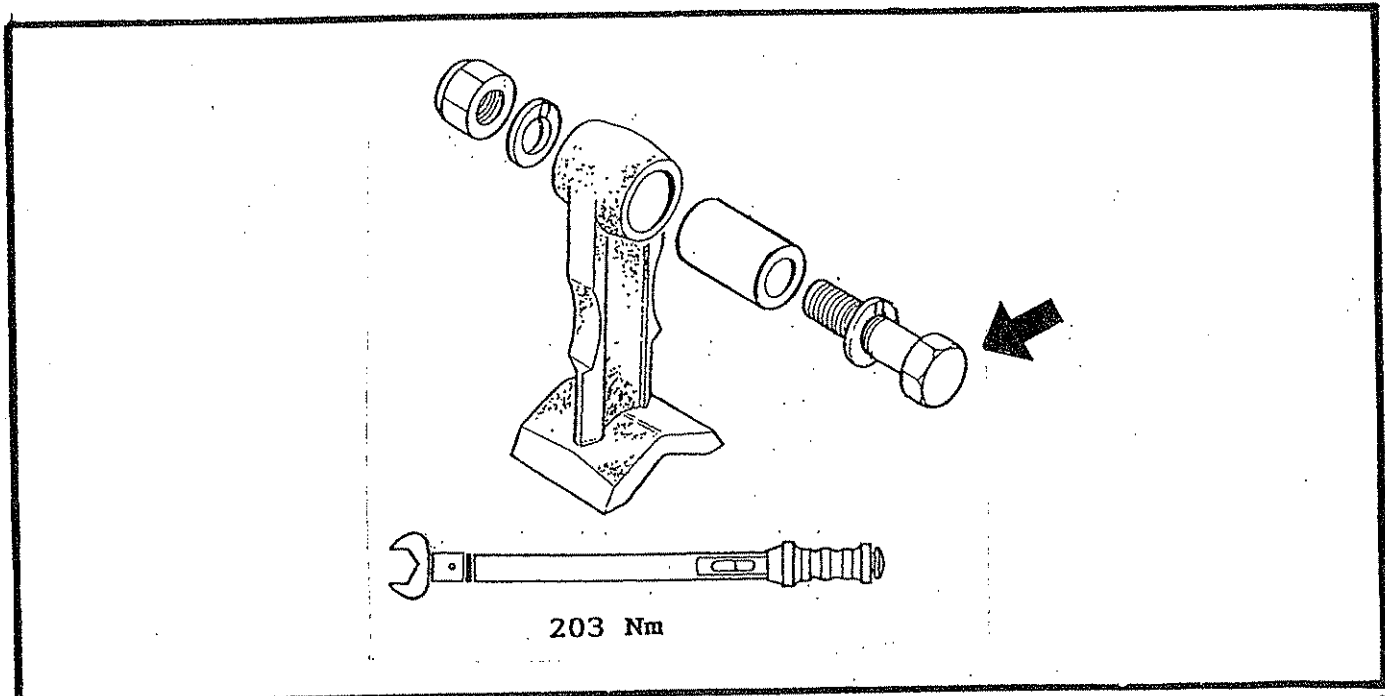

LUBRICATION

Grease daily all points shown.

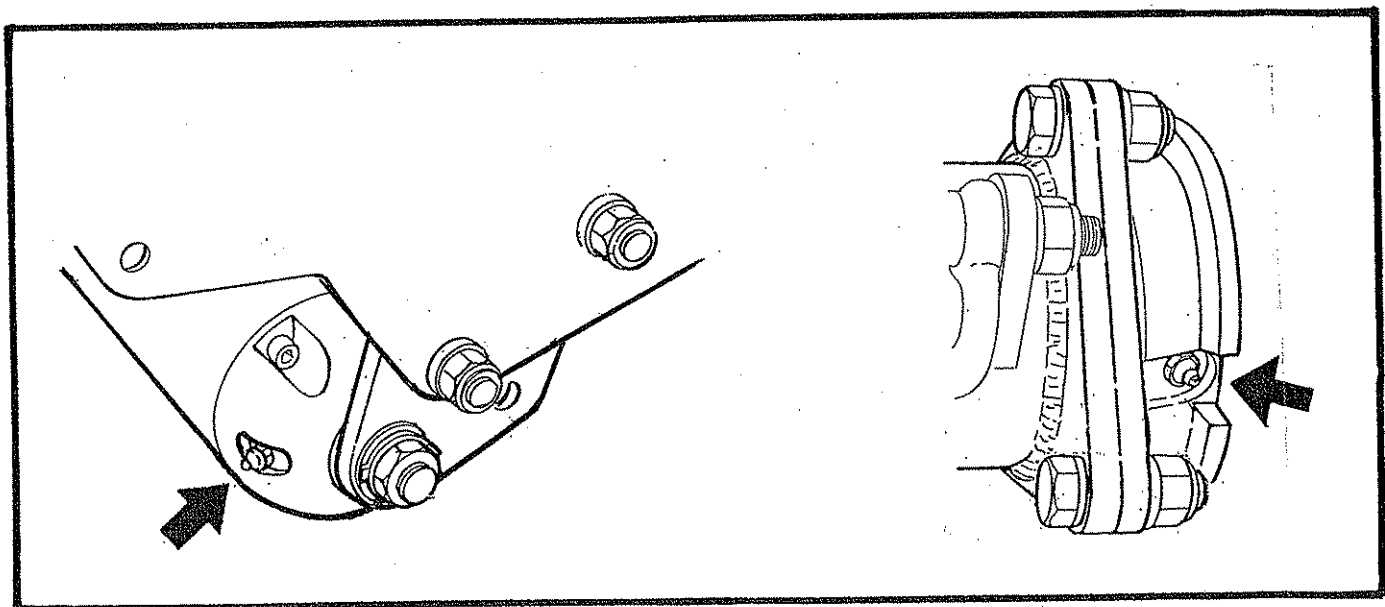

FOR NOTES

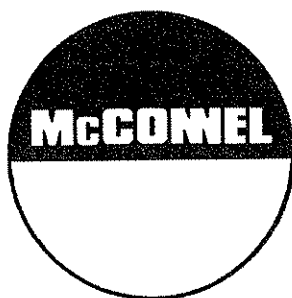

For best performance...

USE ONLY McCONNEL SERVICE PARTS

To be assured of the latest design improvements purchase your 'Genuine Replacements' from the Original Equipment Manufacturer: McCONNEL LIMITED through your local Dealer or Stockist.

Always quote:

- **Machine Type**
- **Serial Number**
- **Part Number**

Design Improvements may have altered some of the parts listed in this manual – The latest part will always be supplied when it is interchangeable with an earlier one.



Genuine Parts - Quality Service

**BUILD VERSIONS**

MODULE PART No.	FLAILHEAD MODEL DESCRIPTION	MOTOR HP / LOCATION	FLAIL TYPE FITTED	FLAIL PART No.
7377700	1.5M MULTICUT - L/H Build	54HP OUTBOARD	CAST D/E F10	7314366
7377701	1.5M MULTICUT - R/H Build	54HP OUTBOARD	CAST D/E F10	7314366
7377702	1.5M MULTICUT - L/H Build	54HP OUTBOARD	CAST S/E F10	7390276
7377703	1.5M MULTICUT - R/H Build	54HP OUTBOARD	CAST S/E F10	7390276
7377704	1.5M MULTICUT - L/H Build	54HP OUTBOARD	FORGED D/E F10	41391.01
7377705	1.5M MULTICUT - R/H Build	54HP OUTBOARD	FORGED D/E F10	41391.01
7377720	1.5M MULTICUT - L/H Build	54HP OUTBOARD	GRASS F10	7190315
7377721	1.5M MULTICUT - R/H Build	54HP OUTBOARD	GRASS F10	7190315
7377740	1.5M MULTICUT - L/H Build	54HP OUTBOARD	FORGED BOOT	7190462
7377741	1.5M MULTICUT - R/H Build	54HP OUTBOARD	FORGED BOOT	7190462
7377800	1.5M MULTICUT - L/H Build	65HP OUTBOARD	CAST D/E F10	7314366
7377801	1.5M MULTICUT - R/H Build	65HP OUTBOARD	CAST D/E F10	7314366
7377802	1.5M MULTICUT - L/H Build	65HP OUTBOARD	CAST S/E F10	7390276
7377803	1.5M MULTICUT - R/H Build	65HP OUTBOARD	CAST S/E F10	7390276
7377804	1.5M MULTICUT - L/H Build	65HP OUTBOARD	FORGED D/E F10	41391.01
7377805	1.5M MULTICUT - R/H Build	65HP OUTBOARD	FORGED D/E F10	41391.01
7377820	1.5M MULTICUT - L/H Build	65HP OUTBOARD	GRASS F10	7190315
7377821	1.5M MULTICUT - R/H Build	65HP OUTBOARD	GRASS F10	7190315
7377840	1.5M MULTICUT - L/H Build	65HP OUTBOARD	FORGED BOOT	7190462
7377841	1.5M MULTICUT - R/H Build	65HP OUTBOARD	FORGED BOOT	7190462

OPTIONS

7198315	FRONT FLAP KIT
7352251	SKID KIT

FLAILHEAD CASING ASSEMBLY

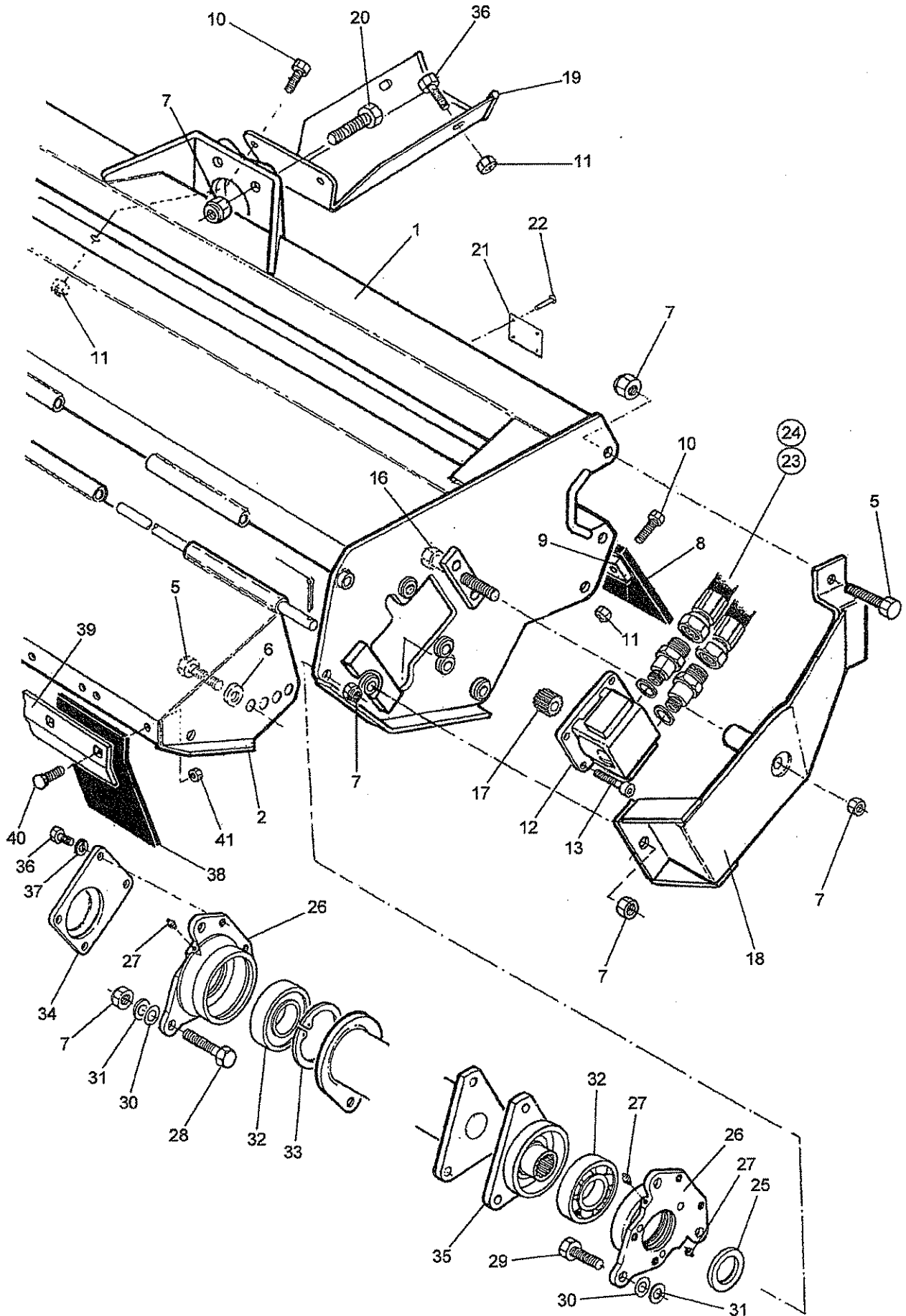

FLAILHEAD CASING ASSEMBLY

Ref.	Qty.	Part No.	Description
			FLAIL HEAD CASING
1	1	42427.01	Casing
2	1	42431.01	Front hood
3	1	41293.03	Pivot pin - hood
4	1	9501406	Split pin
5	4	30.073.25	Special bolt
6	2	0100106	Plain washer
7	21	9100028	Special self locking nut
8	1	42440.01	Rear flap
9	1	42439.01	Clamp strip
10	11	93 13 065	Setscrew
11	13	9143005	Self locking nut
12	1	8301302	Motor - 54Hp
	1	8301301	Motor - 65Hp
13	4	9300144	Capscrew
14	2	8581411	Adaptor
15	2	8650105	Bonded seal
16	1	9200034	Special bolt
17	1	43390.02	Drive coupling
18	1	43486.02	Motor cover - R. Hand
	1	43486.01	Motor cover - L. Hand
19	1	42438.01	Hose tray
20	4	12.714.75	Special bolt
21	1	13 15 246	Serial No. plate
22	4	7103230	Pop rivet
23	2	42732.24	Hose - M36 x 1400 long - motor outboard
24	2	42732.26	Hose - M36 x 1600 long - motor inboard
25	1	7190015	Motor locating washer
26	Z	7190261	Bearing housing
27	4	0901 121	Greaser
28	5	9200025	Special bolt
29	1	9200031	Special bolt
30	<i>as reqd.</i>	8121043	Shim .016"
31	<i>as reqd.</i>	8121 004	Shim .024"
32	2	0600018	Bearing
33	1	7190022	Internal circlip
34	1	7190292	Cover plate
35	1	43389.04	Drive hub
36	6	93 13 045	Setscrew
37	4	9100205	Spring washer
		7198 315	FRONT FLAP KIT
38	10	7191020	Flap
39	1	7198065	Clamp strip
40	20	9293054	Bolt - cup square
41	20	9143 004	Self locking nut
		8699236	SEAL KIT - for hydraulic motor

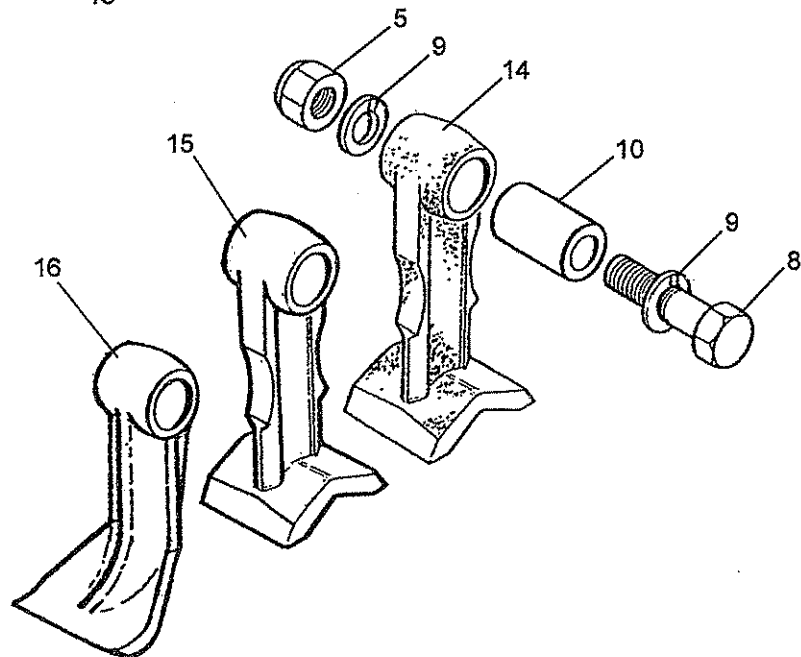
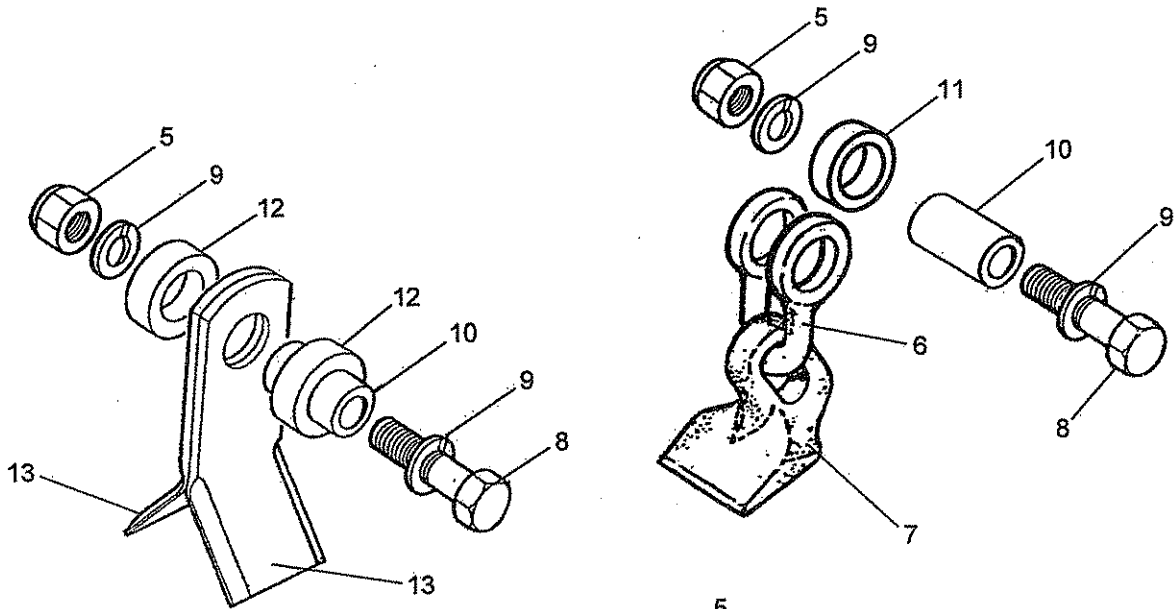
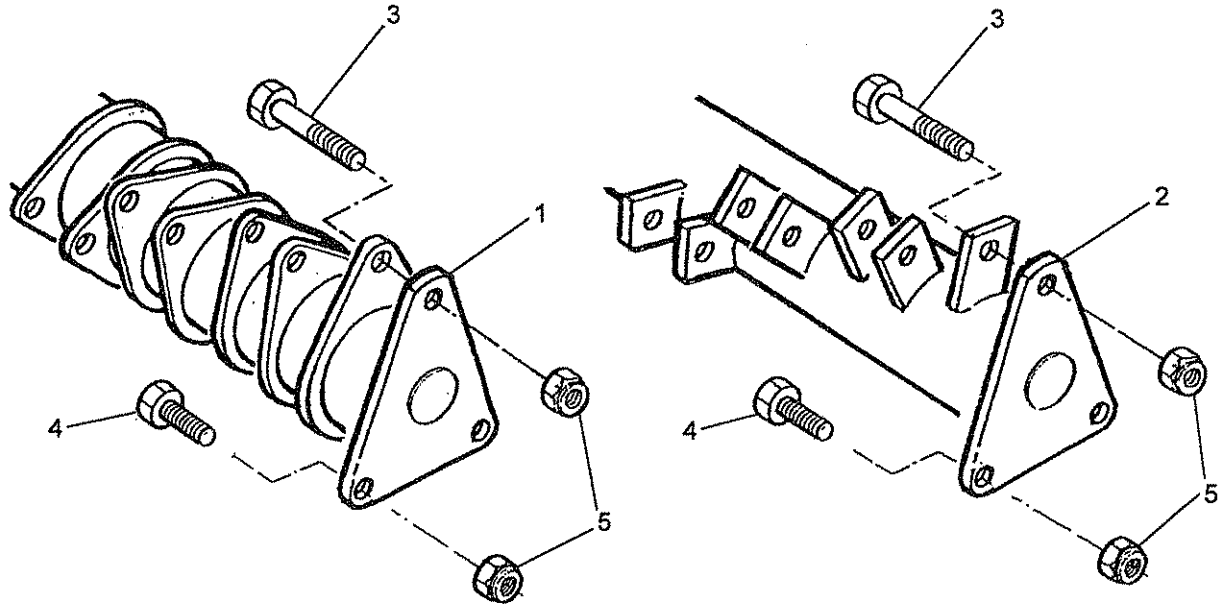



ROTORS & FLAILS ASSEMBLY

Ref.	Qty.	Part No.	Description
			ROTORS & FLAILS
1	1	43391.01	Rotor - Wrap Around Lug Type
2	1	42428.02	Rotor - Square Lug Type
3	1	7390026	Special Bolt
4	2	9200028	Special Bolt
5	30	9100028	Special Self-Locking Nut
6	28	7190106	Shackle
7	28	7190462	Flail - Forged Boot
8	27	7390025	Special Bolt
9	56	0100206	Spring Washer
10	28	7314223	Pivot Bush
11	28	7190172	Spacer
12	56	7190010	Spacer
13	56	7190315	Flail - F10 Grass
14	28	7314366	Flail - F10H Cast
15	28	41391.01	Flail - F10H Forged
16	28	7390276	Flail - Single Edged

ROLLER ASSEMBLY

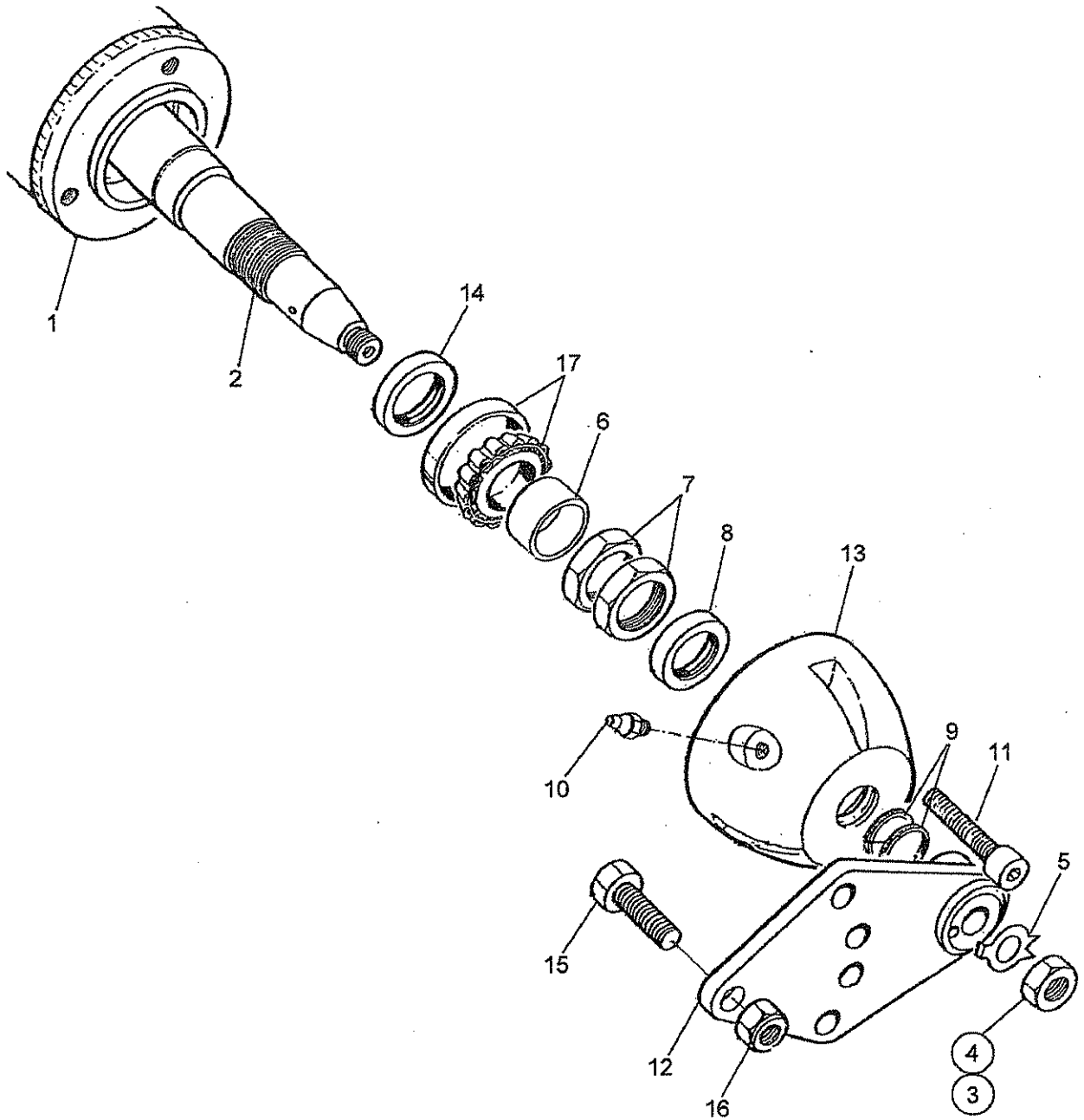
Module:
42241.28





ROLLER ASSEMBLY

Ref.	Qty.	Part No.	Description
		42241.28	ROLLER ASSEMBLY
1	1	42241.03	Roller
	1	42242.15	Axle Assembly - <i>including:</i>
2	1	42242.03	Axle
3	1	9113008	Plain Nut - R/H (<i>not illustrated</i>)
4	1	9100026	Plain Nut - L/H
5	2	7190023	Tab Washer
6	2	42245.01	Spacer
7	4	42244.01	Locknut
8	2	8629125	Seal
9	4	0412120	Spirolox Ring
10	2	0901121	Greaser - Straight
11	6	9343075	Capscrew
12	1	42246.03	Roller Bracket
13	2	42243.01	End Cap
14	2	8629213	Seal
15	4	9113107	Bolt
16	4	9143007	Self-Locking Nut
17	2	0600105	Taper Roller Bearing

SKID KIT ASSEMBLY (Optional)

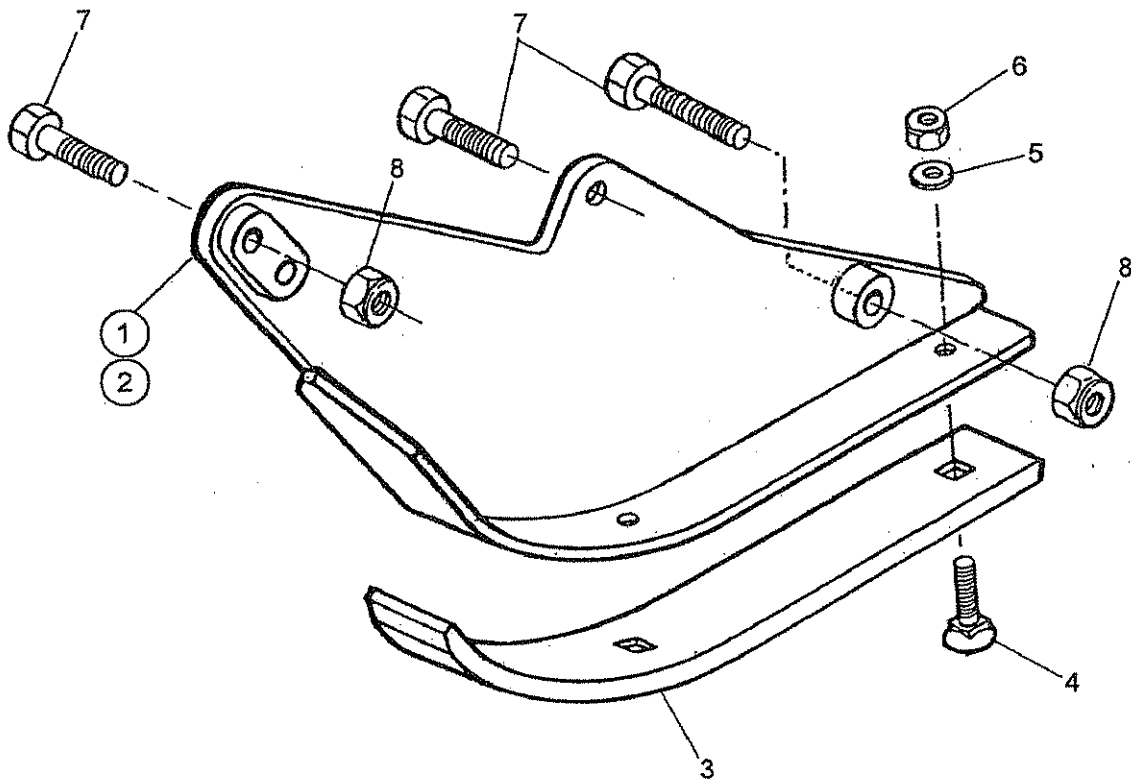
Module:
7352251



**SKID KIT ASSEMBLY (Optional)**

Ref.	Qty.	Part No.	Description
		7352251	SKID KIT
1	1	42436.01	Skid - L/H
2	1	42436.02	Skid - R/H <i>(not illustrated)</i>
3	2	7290391	Wear Skid
4	6	6012034	Tine Bolt
5	6	0100104	Plain Washer
6	6	0142004	Self-Locking Nut
7	6	30.073.25	Special Bolt
8	6	9100028	Special Self-Locking Nut

DECALS

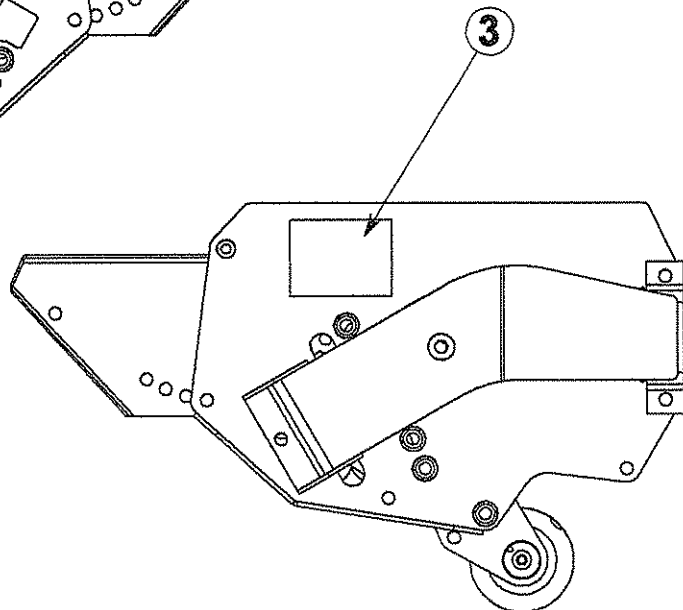
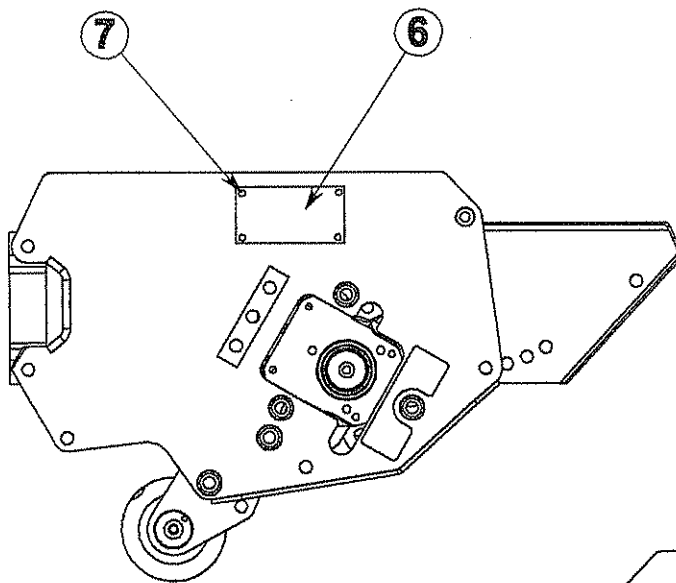
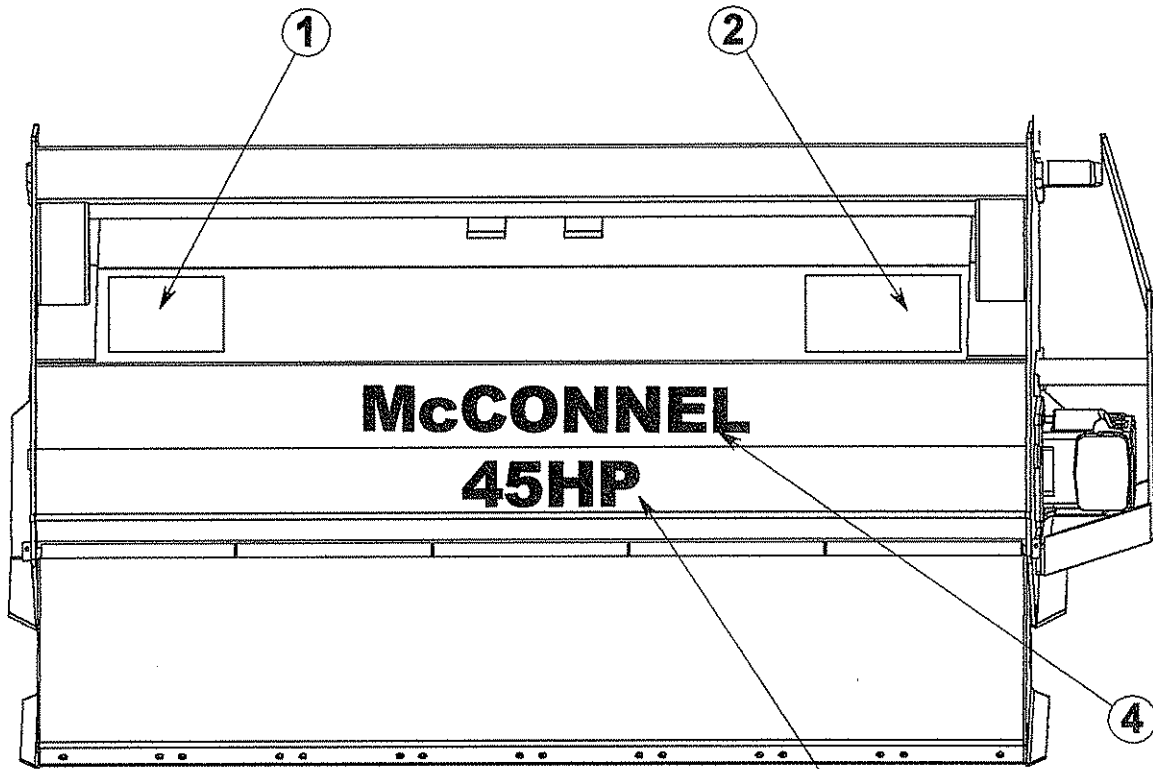



DECALS

Ref.	Qty.	Part No.	Description
1	1	1290462	Decal - Flail Warning
2	1	1290341	Decal - Flail Guarding
3	1	1290392	Decal - Flail Parts Information
4	1	1290255	Decal - McConnell Name
5	1	1290508	Decal - 54HP
	1	1290491	Decal - 65HP
6	1	1335246	Serial No. Plate
7	1	7103230	Pop Rivets
8	1	09.810.01	Decal - Grease 8 Hours
9	1	1290571	Decal - Queens Award

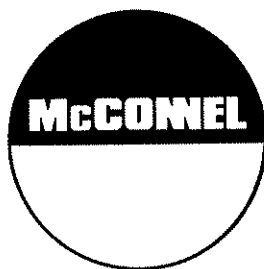

McConnel Limited, Temeside Works, Ludlow, Shropshire SY8 1JL. England.
Telephone: 01584 873131. Facsimile: 01584 876463. www.mcconnel.com