

Publication 495  
November 2005  
Part No. 41570.95



# FLAILHEAD

## 0.9M Sliding Head

Operator & Parts Manual

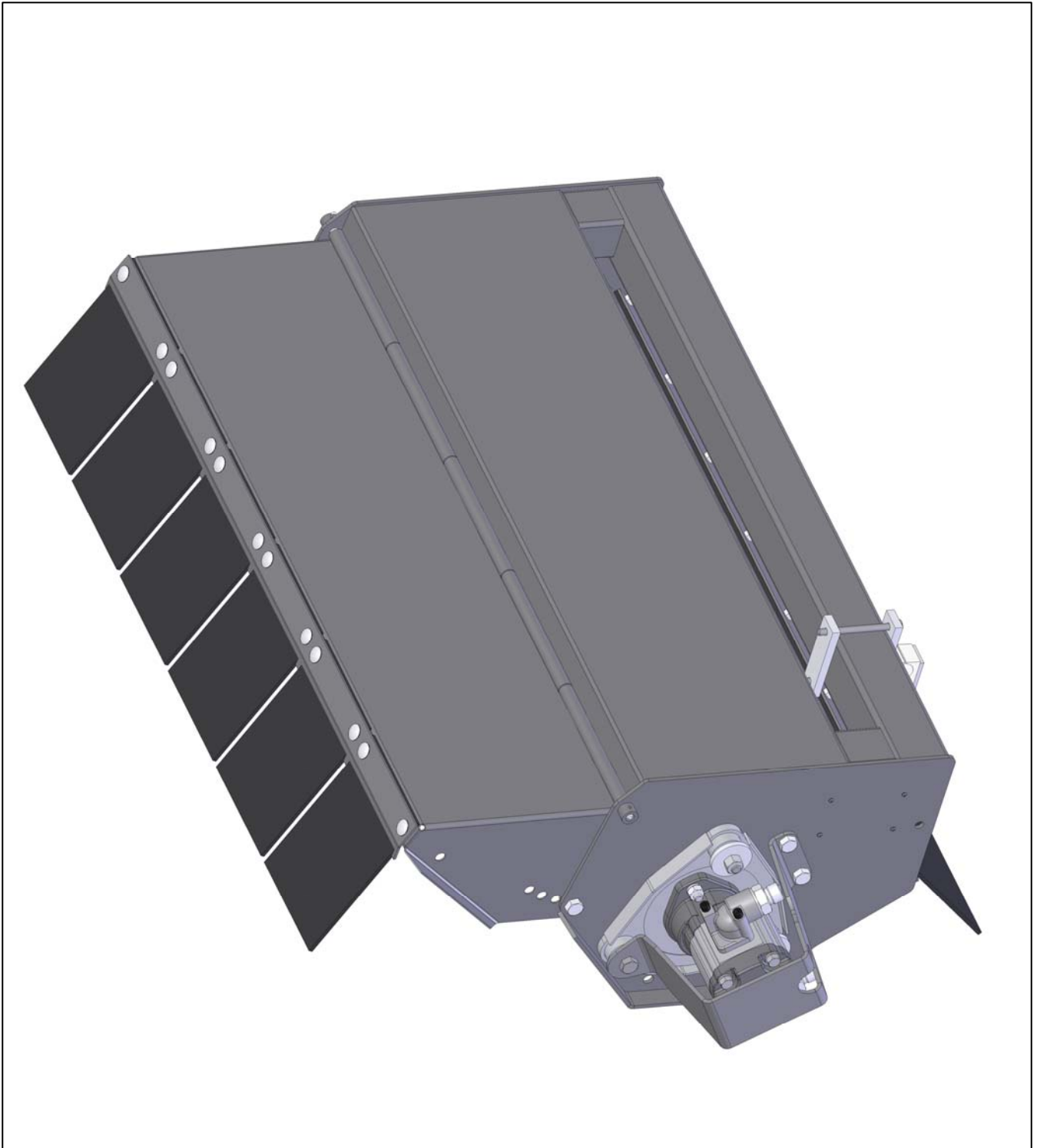

# IMPORTANT VERIFICATION OF WARRANTY REGISTRATION

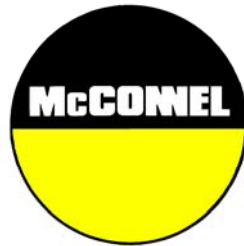

## DEALER WARRANTY INFORMATION & REGISTRATION VERIFICATION

It is imperative that the selling dealer registers this machine with McConnel Limited before delivery to the end user – failure to do so may affect the validity of the machine warranty.

To register machines go to the McConnel Limited web site at [www.mcconnel.com](http://www.mcconnel.com), log onto 'Dealer Inside' and select the 'Machine Registration button' which can be found in the Service Section of the site. Confirm to the customer that the machine has been registered in the section below.

Should you experience any problems registering a machine in this manner please contact the McConnel Service Department on 01584 875848.

### Registration Verification

Dealer Name: .....
Dealer Address: .....
Customer Name: .....
Date of Warranty Registration: ...../...../..... Dealer Signature: .....

### NOTE TO CUSTOMER / OWNER

*Please ensure that the above section above has been completed and signed by the selling dealer to verify that your machine has been registered with McConnel Limited.*

**IMPORTANT:** During the initial 'bedding in' period of a new machine it is the customer's responsibility to regularly inspect all nuts, bolts and hose connections for tightness and re-tighten if required. New hydraulic connections occasionally weep small amounts of oil as the seals and joints settle in – where this occurs it can be cured by re-tightening the connection – *refer to torque settings chart below*. The tasks stated above should be performed on an hourly basis during the first day of work and at least daily thereafter as part of the machines general maintenance procedure.

### TORQUE SETTINGS FOR HYDRAULIC FITTINGS

HYDRAULIC HOSE ENDS		
BSP	Setting	Metric
1/4"	18 Nm	19 mm
3/8"	31 Nm	22 mm
1/2"	49 Nm	27 mm
5/8"	60 Nm	30 mm
3/4"	80 Nm	32 mm
1"	125 Nm	41 mm
1.1/4"	190 Nm	50 mm
1.1/2"	250 Nm	55 mm
2"	420 Nm	70 mm

PORT ADAPTORS WITH BONDED SEALS		
BSP	Setting	Metric
1/4"	34 Nm	19 mm
3/8"	47 Nm	22 mm
1/2"	102 Nm	27 mm
5/8"	122 Nm	30 mm
3/4"	149 Nm	32 mm
1"	203 Nm	41 mm
1.1/4"	305 Nm	50 mm
1.1/2"	305 Nm	55 mm
2"	400 Nm	70 mm

# WARRANTY POLICY

## WARRANTY REGISTRATION

All machines must be registered, by the selling dealer with McConnel Ltd, before delivery to the end user. On receipt of the goods it is the buyer's responsibility to check that the Verification of Warranty Registration in the Operator's Manual has been completed by the selling dealer.

### 1. LIMITED WARRANTIES

- 1.01. *All machines supplied by McConnel Ltd are warranted to be free from defects in material and workmanship from the date of sale to the original purchaser for a period of 12 months, unless a different period is specified.*
- 1.02. *All spare parts supplied by McConnel Ltd and purchased by the end user are warranted to be free from defects in material and workmanship from the date of sale to the original purchaser for a period of 6 months. All parts warranty claims must be supported by a copy of the failed part invoice to the end user. We cannot consider claims for which sales invoices are not available.*
- 1.03. *The warranty offered by McConnel Ltd is limited to the making good by repair or replacement for the purchaser any part or parts found, upon examination at its factory, to be defective under normal use and service due to defects in material or workmanship. Returned parts must be complete and unexamined. Pack the component(s) carefully so that any transit damage is avoided. All ports on hydraulic items should be drained of oil and securely plugged to prevent seepage and foreign body ingress. Certain other components, electrical items for example, may require particular care when packing to avoid damage in transit.*
- 1.04. *This warranty does not extend to any product from which McConnel Ltd's serial number plate has been removed or altered.*
- 1.05. *This warranty does not apply to any part of the goods, which has been subjected to improper or abnormal use, negligence, alteration, modification, fitment of non-genuine parts, accident damage, or damage resulting from contact with overhead power lines, damage caused by foreign objects (e.g. stones, iron, material other than vegetation), failure due to lack of maintenance, use of incorrect oil or lubricants, contamination of the oil, or which has served its normal life. This warranty does not apply to any expendable items such as blades, belts, clutch linings, filter elements, flails, flap kits, skids, soil engaging parts, shields, guards, wear pads, pneumatic tyres or tracks.*
- 1.06. *Temporary repairs and consequential loss - i.e. oil, downtime and associated parts are specifically excluded from the warranty.*
- 1.07. *Warranty on hoses is limited to 12 months and does not include hoses which have suffered external damage. Only complete hoses may be returned under warranty, any which have been cut or repaired will be rejected.*
- 1.08. *Machines must be repaired immediately a problem arises. Continued use of the machine after a problem has occurred can result in further component failures, for which McConnel Ltd cannot be held liable, and may have safety implications.*
- 1.09. *If in exceptional circumstances a non McConnel Ltd part is used to effect a repair, warranty reimbursement will be at no more than McConnel Ltd's standard dealer cost for the genuine part.*
- 1.10. *Except as provided herein, no employee, agent, dealer or other person is authorised to give any warranties of any nature on behalf of McConnel Ltd.*
- 1.11. *For machine warranty periods in excess of 12 months the following additional exclusions shall apply:*
  - 1.11.1. *Hoses, exposed pipes and hydraulic tank breathers.*
  - 1.11.2. *Filters.*
  - 1.11.3. *Rubber mountings.*
  - 1.11.4. *External electric wiring.*
  - 1.11.5. *Bearings and seals.*

- 1.12. All service work, particularly filter changes, must be carried out in accordance with the manufacturer's service schedule. Failure to comply will invalidate the warranty. In the event of a claim, proof of the service work being carried out may be required.
- 1.13. Repeat or additional repairs resulting from incorrect diagnosis or poor quality previous repair work are excluded from warranty.

**NB Warranty cover will be invalid if any non-genuine parts have been fitted or used. Use of non-genuine parts may seriously affect the machine's performance and safety. McConnell Ltd cannot be held responsible for any failures or safety implications that arise due to the use of non-genuine parts.**

## **2. REMEDIES AND PROCEDURES**

- 2.01. The warranty is not effective unless the Selling Dealer registers the machine, via the McConnell Ltd web site and confirms the registration to the purchaser by completing the confirmation form in the operator's manual.
- 2.02. Any fault must be reported to an authorised McConnell Ltd dealer as soon as it occurs. Continued use of a machine, after a fault has occurred, can result in further component failure for which McConnell Ltd cannot be held liable.
- 2.03. Repairs should be undertaken within two days of the failure. Claims submitted for repairs undertaken more than 2 weeks after a failure has occurred, or 2 days after the parts were supplied will be rejected, unless the delay has been authorised by McConnell Ltd. Please note that failure by the customer to release the machine for repair will not be accepted as a reason for delay in repair or submitting warranty claims.
- 2.04. All claims must be submitted, by an authorised McConnell Ltd Service Dealer, within 30 days of the date of repair.
- 2.05. Following examination of the claim and parts, McConnell Ltd will pay, at their discretion, for any valid claim the invoiced cost of any parts supplied by McConnell Ltd and appropriate labour and mileage allowances if applicable.
- 2.06. The submission of a claim is not a guarantee of payment.
- 2.07. Any decision reached by McConnell Ltd is final.

## **3. LIMITATION OF LIABILITY**

- 3.01. McConnell Ltd disclaims any express (except as set forth herein) and implied warranties with respect to the goods including, but not limited to, merchantability and fitness for a particular purpose.
- 3.02. McConnell Ltd makes no warranty as to the design, capability, capacity or suitability for use of the goods.
- 3.03. Except as provided herein, McConnell Ltd shall have no liability or responsibility to the purchaser or any other person or entity with respect to any liability, loss, or damage caused or alleged to be caused directly or indirectly by the goods including, but not limited to, any indirect, special, consequential, or incidental damages resulting from the use or operation of the goods or any breach of this warranty. Notwithstanding the above limitations and warranties, the manufacturer's liability hereunder for damages incurred by the purchaser or others shall not exceed the price of the goods.
- 3.04. No action arising out of any claimed breach of this warranty or transactions under this warranty may be brought more than one (1) year after the cause of the action has occurred.

## **4. MISCELLANEOUS**

- 4.01. McConnell Ltd may waive compliance with any of the terms of this limited warranty, but no waiver of any terms shall be deemed to be a waiver of any other term.
- 4.02. If any provision of this limited warranty shall violate any applicable law and is held to be unenforceable, then the invalidity of such provision shall not invalidate any other provisions herein.
- 4.03. Applicable law may provide rights and benefits to the purchaser in addition to those provided herein.



# DECLARATION OF CONFORMITY

*Conforming to EU Machinery Directive 2006/42/EC*

We,

**McCONNEL LIMITED**, Temeside Works, Ludlow, Shropshire SY8 1JL, UK

*Hereby declare that:*

The Product; *Hydraulic Arm Mounted Flailhead*

Product Code; *BD12, BD16, F110, F112, F115, F012, F016*

Serial No. & Date ..... Type .....

Manufactured in; *United Kingdom*

Complies with the required provisions of the Machinery Directive 2006/42/EC  
The machinery directive is supported by the following harmonized standards;

- BS EN ISO 12100 (2010) Safety of machinery – General principles for design – Risk assessment and risk reduction.
- BS EN 349 (1993) + A1 (2008) Safety of machinery - Minimum distances to avoid the entrapment with human body parts.
- BS EN 953 (1997) + A1 (2009) Safety of machinery - Guards general requirements for the design and construction of fixed and movable guards.
- BS EN 4413 (2010) Hydraulic fluid power. Safety requirements for systems and their components.

McCONNEL LIMITED operates an ISO 9001:2008 quality management system, certificate number: FM25970.

This system is continually assessed by the;

British Standards Institution (BSI), Beech House, Milton Keynes, MK14 6ES, UK  
BSI is accredited by UK Accreditation Service, accreditation number: UKAS 003.

The EC declaration only applies if the machine stated above is used in accordance with the operating instructions.

Signed ..... *Responsible Person*

*CHRISTIAN DAVIES on behalf of McCONNEL LIMITED*

Status: *General Manager*

Date: *September 2015*

# CONTENTS

---

	<i>Page No.</i>
<b>Operator Section</b>	
General Information	3
Safety Information	5
Cutting Limitations	9
Roller Positions	9
Flailhead Arrangement for Mowing	10
Flailhead Arrangement for Hedge Cutting	11
Tractor Forward Speed	12
Hedgecutting Procedure	13
Wire Trap	14
Maintenance	14
<b>Parts Section</b>	
Flailhead Assembly	16
Rotor Assembly	20
Roller Assembly	21



## GENERAL INFORMATION

---

Always read this manual before fitting or operating the machine – whenever any doubt exists contact your dealer or the McConnell Service Department for advice and assistance.

Use only McConnell Genuine Service Parts on McConnell Equipment and Machines

DEFINITIONS – *The following definitions apply throughout this manual:*

### WARNING

*An operating procedure, technique etc., which –  
can result in personal injury or loss of life if not observed carefully.*

### CAUTION

*An operating procedure, technique etc., which –  
can result in damage to either machine or equipment if not observed carefully.*

### NOTE

*An operating procedure, technique etc., which –  
is considered essential to emphasis.*

### LEFT AND RIGHT HAND

*This term is applicable to the machine when attached to the tractor and is viewed  
from the rear – this also applies to tractor references.*

## MACHINE & DEALER INFORMATION

***Record the Serial Number of your machine on this page and always quote this number  
when ordering parts. Whenever information concerning the machine is requested  
remember also to state the make and model of tractor to which the machine is fitted.***

Machine Serial Number:

Installation Date:

Machine Model details:

Dealer Name:

Dealer Address:

Dealer Telephone No:

Dealer Email Address:







# SAFETY INFORMATION



This machine has the potential to be extremely dangerous, in the wrong hands it can kill or maim. It is therefore imperative that both owner, and operator of this machine, read and understand the following section to ensure that they are fully aware of the dangers that do, or may exist, and their responsibilities surrounding the use and operation of the machine. The operator of this machine is responsible not only for their own safety but equally for the safety of others who may come into the close proximity of the machine, as the owner you are responsible for both.

When the machine is not in use the cutting head should be lowered to rest on the ground. In the event of a fault being detected with the machine's operation it should be stopped immediately and not used again until the fault has been corrected by a qualified technician.

## POTENTIAL SIGNIFICANT DANGERS ASSOCIATED WITH THE USE OF THIS MACHINE:

- ▲ *Being hit by debris thrown by rotating components.*
- ▲ *Being hit by machine parts ejected through damage during use.*
- ▲ *Being caught on a rotating power take-off (PTO) shaft.*
- ▲ *Being caught in other moving parts i.e.: belts, pulleys and cutting heads.*
- ▲ *Electrocution from Overhead Power Lines (by contact with or 'flashover' from).*
- ▲ *Being hit by cutting heads or machine arms as they move.*
- ▲ *Becoming trapped between tractor and machine when hitching or unhitching.*
- ▲ *Tractor overbalancing when machine arm is extended.*
- ▲ *Injection of high-pressure oil from hydraulic hoses or couplings.*
- ▲ *Machine overbalancing when freestanding (out of use).*
- ▲ *Road traffic accidents due to collision or debris on the road.*

## BEFORE USING THIS MACHINE YOU MUST:

- ▲ *Ensure you read all sections of the operator handbook.*
- ▲ *Ensure the operator is, or has been, properly trained to use the machine.*
- ▲ *Ensure the operator has been issued with and reads the operator handbook.*
- ▲ *Ensure the operator understands and follows the instructions in operator handbook.*
- ▲ *Ensure the tractor front, rear and side(s) are fitted with metal mesh or polycarbonate guards of suitable size and strength to protect the operator against thrown debris or parts.*
- ▲ *Ensure tractor guards are fitted correctly, are undamaged and kept properly maintained.*
- ▲ *Ensure that all machine guards are in position, are undamaged, and are kept maintained in accordance with the manufacturer's recommendations.*
- ▲ *Ensure flails and their fixings are of a type recommended by the manufacturer, are securely attached and that none are missing or damaged.*
- ▲ *Ensure hydraulic pipes are carefully and correctly routed to avoid damage by chaffing, stretching or pinching and that they are held in place with the correct fittings.*
- ▲ *Always follow the manufacturer's instructions for attachment and removal of the machine from the tractor.*
- ▲ *Check that the machine fittings and couplings are in good condition.*
- ▲ *Ensure the tractor meets the minimum weight recommendations of the machine's manufacturer and that ballast is used as necessary.*
- ▲ *Always inspect the work area thoroughly before starting to note obstacles and remove wire, bottles, cans and other debris.*
- ▲ *Use clear suitably sized warning signs to alert others to the nature of the machine working within that area. Signs should be placed at both ends of the work site. (It is recommended that signs used are of a size and type specified by the Department of Transport and positioned in accordance with their, and the Local Highways Authority, guidelines).*
- ▲ *Ensure the operator is protected from noise. Ear defenders should be worn and tractor cab doors and windows must be kept closed. Machine controls should be routed through proprietary openings in the cab to enable all windows to be shut fully.*
- ▲ *Always work at a safe speed taking account of the conditions i.e.: terrain, highway proximity and obstacles around and above the machine. Extra special attention should be applied to Overhead Power Lines. Some of our machines are capable of reach in excess of 8 metres (26 feet) this means they have the potential to well exceed, by possibly 3 metres (9' 9"), the lowest legal minimum height of 5.2 metres from the ground for 11,000 and 33,000 volt power lines. It cannot be stressed enough the dangers that surround this capability, it is therefore vital that the operator is fully aware of the maximum height and reach of the machine, and that they are fully conversant with all aspects regarding the safe minimum distances that apply when working with machines in close proximity to Power Lines. (Further information on this subject can be obtained from the Health & Safety Executive or your Local Power Company).*

- ▲ *Always disengage the machine, kill the tractor engine, remove and pocket the key before dismounting for any reason.*
- ▲ *Always clear up all debris left at the work area, it may cause hazard to others.*
- ▲ *Always ensure when you remove your machine from the tractor that it is left in a safe and stable position using the stands and props provided and secured if necessary.*

#### WHEN NOT TO USE THIS MACHINE:

- ▲ *Never attempt to use this machine if you have not been trained to do so.*
- ▲ *Never use a machine until you have read and understood the operator handbook, are familiar with it, and practiced the controls.*
- ▲ *Never use a machine that is poorly maintained.*
- ▲ *Never use a machine if guards are missing or damaged.*
- ▲ *Never use a machine on which the hydraulic system shows signs of wear or damage.*
- ▲ *Never fit, or use, a machine on a tractor that does not meet the manufacturer's minimum specification level.*
- ▲ *Never use a machine fitted to a tractor that does not have suitable front, rear and side(s) cab guarding made of metal mesh or polycarbonate.*
- ▲ *Never use the machine if the tractor cab guarding is damaged, deteriorating or badly fitted.*
- ▲ *Never turn a machine cutting head to an angle that causes debris to be ejected towards the cab.*
- ▲ *Never start or continue to work a machine if people are nearby or approaching - Stop and wait until they are at a safe distance before continuing. WARNING: Some Cutting Heads may continue to 'freewheel' for up to 40 seconds after being stopped.*
- ▲ *Never attempt to use a machine on materials in excess of its capability.*
- ▲ *Never use a machine to perform a task it has not been designed to do.*
- ▲ *Never operate the tractor or machine controls from any position other than from the driving seat, especially whilst hitching or unhitching the machine.*
- ▲ *Never carry out maintenance of a machine or a tractor whilst the engine is running – the engine should be switched off, the key removed and pocketed.*
- ▲ *Never leave a machine unattended in a raised position – it should be lowered to the ground in a safe position on a level firm site.*
- ▲ *Never leave a tractor with the key in or the engine running.*
- ▲ *Never carry out maintenance on any part or component of a machine that is raised unless that part or component has been properly substantially braced or supported.*
- ▲ *Never attempt to detect a hydraulic leak with your hand – use a piece of cardboard.*
- ▲ *Never allow children near to, or play on, a tractor or machine under any circumstances.*

## ADDITIONAL SAFETY ADVICE

### Training

Operators need to be competent and fully capable of operating this machine in a safe and efficient way prior to attempting to use it in any public place. We advise therefore that the prospective operator make use of relevant training courses available such as those run by the Agricultural Training Board, Agricultural Colleges, Dealers and McConnel.

### Working in Public Places

When working in public places such as roadsides, consideration should be paid to others in the vicinity. Stop the machine immediately when pedestrians, cyclists and horse riders etc. pass. Restart only when they are at a distance that causes no risk to their safety.

### Warning Signs

It is advisable that any working area be covered by suitable warning signs and statutory in public places. Signs should be highly visible and well placed in order to give clear advanced warning of the hazard. Contact the Department of Transport or your Local Highways Authority to obtain detailed information on this subject. The latter should be contacted prior to working on the public highway advising them of the time and location of the intended work asking what is required by way of signs and procedure. – ‘*Non-authorized placement of road signs may create offences under the Highways Act*’.

### Suggested Warning Signs Required

**“Road works ahead”** warning sign with a supplementary **“Hedge cutting”** plate. **“For 1 mile”** or appropriate shorter distance may be added to the plate.

**“Road narrows”** warning sign with supplementary **“Single file traffic”** plate.

White on blue **“Keep right”** (\*) arrow sign on rear of machine.

\* Note – this applies to UK Market machines where traffic passes to the right of a machine working in the same direction as the traffic flow. The direction, use and colour of the arrow sign will depend on the country of use and the Local Highway Authorities regulations in the locality.

### Use of Warning Signs

- ▲ On two-way roads one set of signs is needed facing traffic in each direction.
- ▲ Work should be within 1 mile of the signs.
- ▲ Work only when visibility is good and at times of low risk e.g.: NOT during ‘rush-hour’.
- ▲ Vehicles should have an amber-flashing beacon.
- ▲ Ideally, vehicles should be conspicuously coloured.
- ▲ Debris should be removed from the road and path as soon as practicable, and at regular intervals, wearing high visibility clothing and before removing the hazard warning signs.
- ▲ Collect all road signs promptly when the job is completed.

---

Although the information given here covers a wide range of safety subjects, it is impossible to predict every eventuality that can occur under differing circumstances whilst operating this machine. No advice given here can replace ‘good common sense’ and ‘total awareness’ at all times, but will go a long way towards the safe use of your McConnel machine.

---

# OPERATION

## Material Thickness Cutting Limitations



## Roller Positions

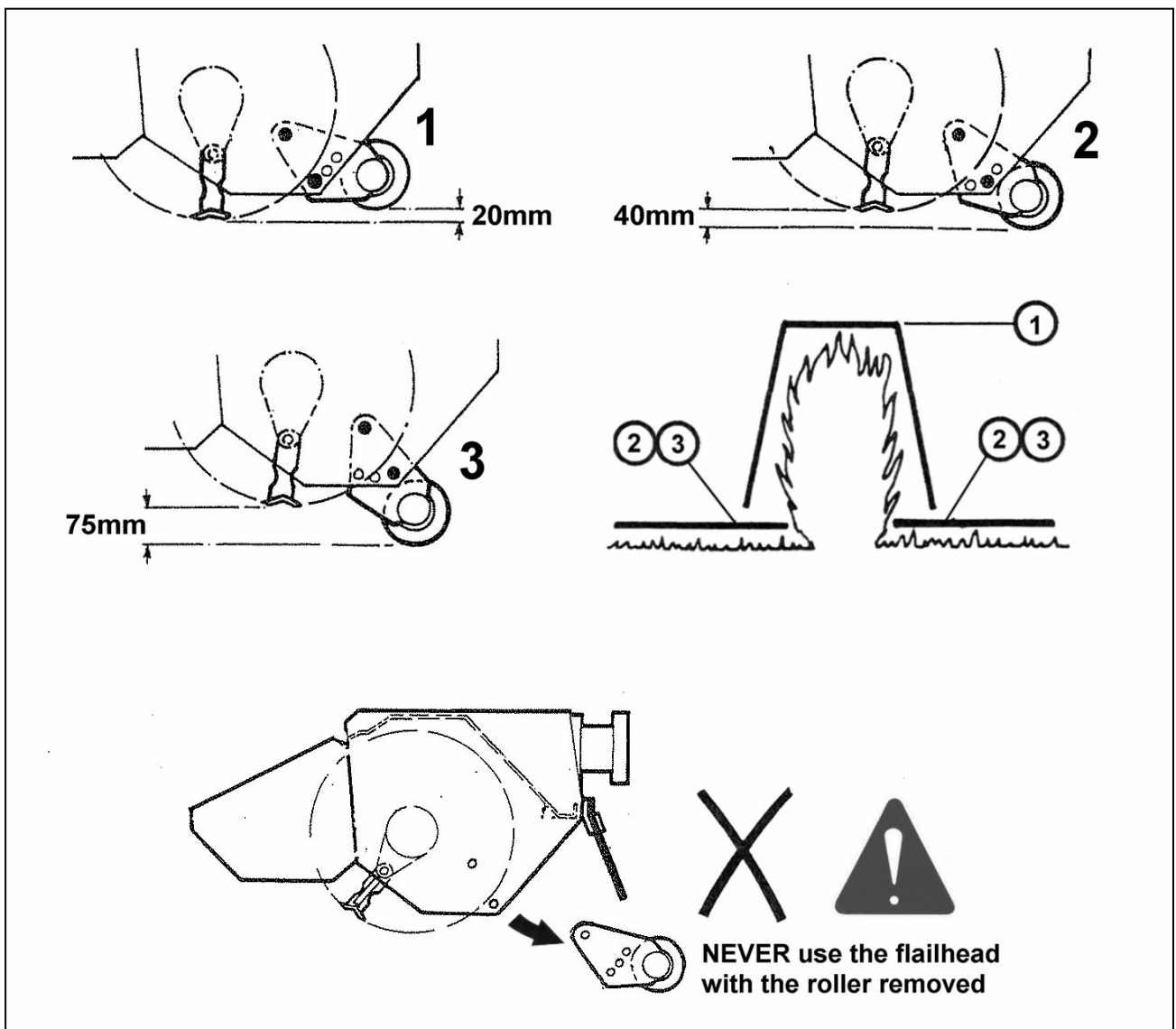

## Preliminary Precautions

Inspect the work area prior to operation, remove all hazardous materials and note the locations of immovable obstructions.

remove all hazardous materials and note the locations of immovable obstructions.

# FLAILHEAD ARRANGEMENT

## MOWING

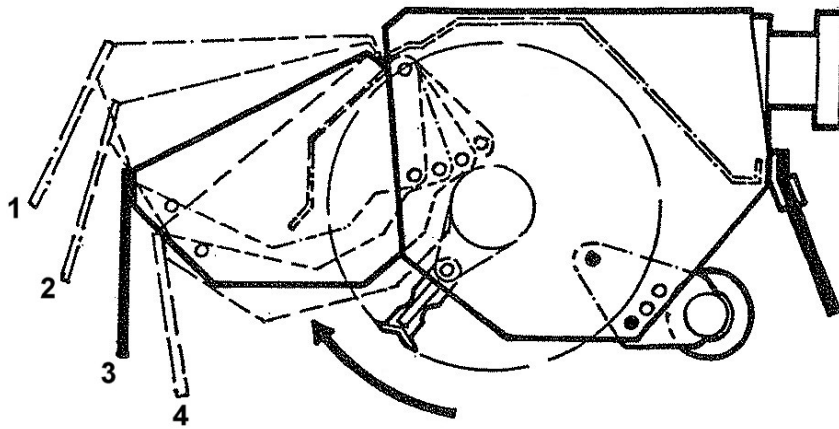

For mowing work the rotor must always cut with an upwards rotation and the roller set to a working height that is below the level of the skids (or rotor if skids are not fitted) – i.e. in position 2, 3, 4 or 5 as shown on the previous page.

The front hood has four height adjustment positions – the lowest possible position which allows the material to be cut to enter the head should always be used.

**WARNING:** Raising the front hood increases the possibility of debris escaping – never operate the machine with the front hood set any higher than is absolutely necessary.

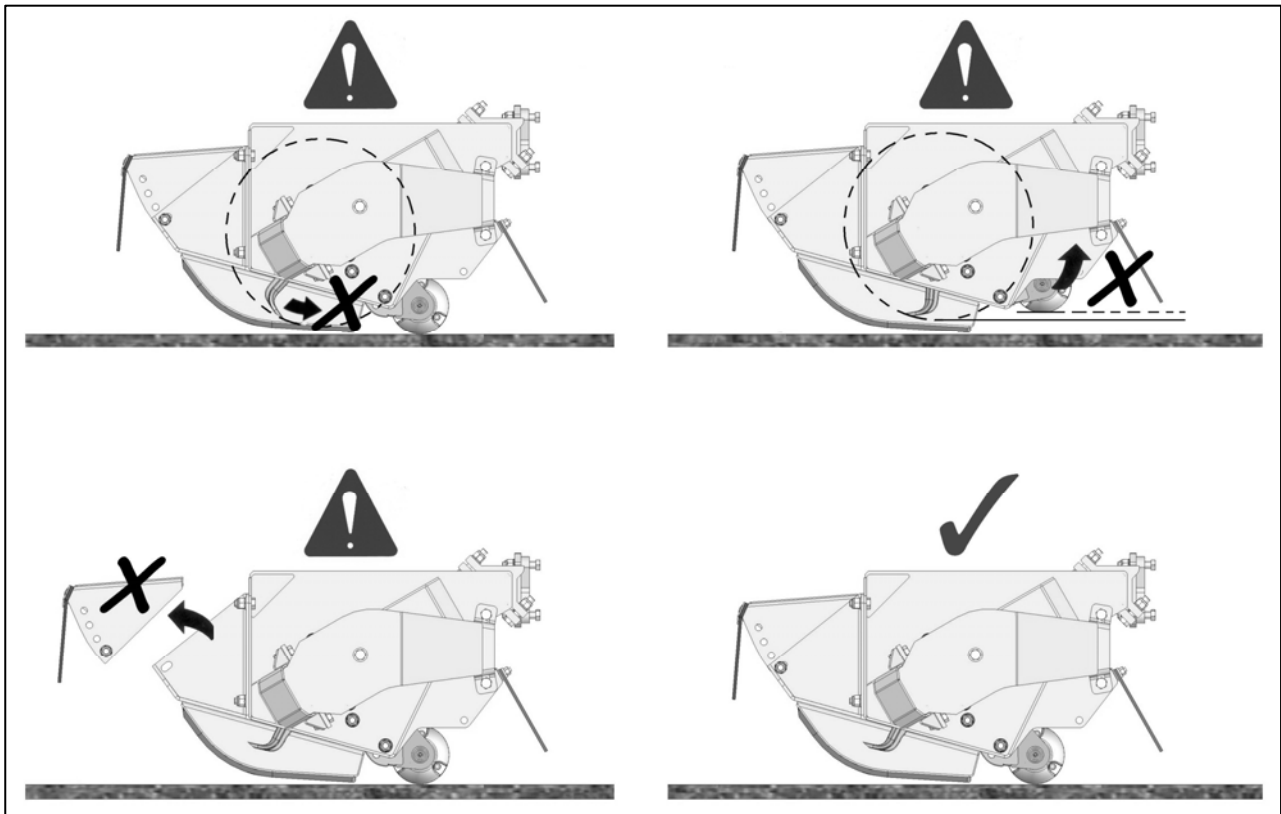

## HEDGE CUTTING – Upward Cutting

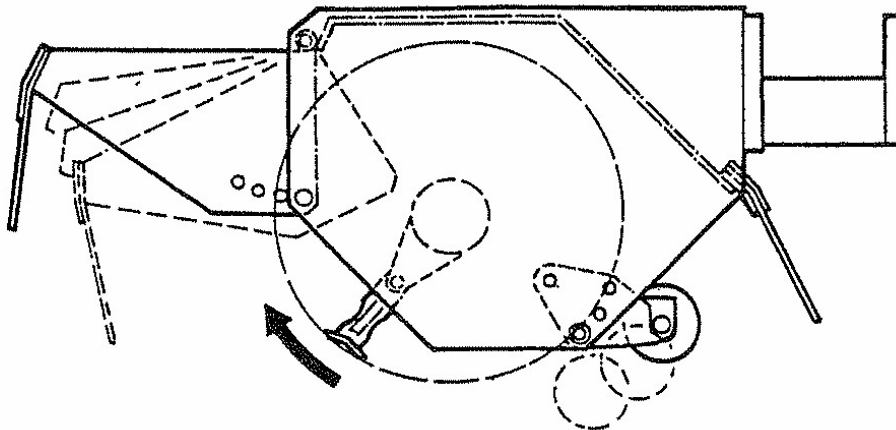

For normal trimming work on hedges the rotor should be set to cut with an upwards rotation – this produces a better finish to the work and demands lower power requirement. Front hood and rear flap must always be in position.

The roller should be set slightly higher than the rotor – i.e. in position 1 as shown on the previous roller position page.

The front hood has four height adjustment positions – the lowest possible position which allows the material to be cut to enter the head should always be used. Front flaps if fitted may be removed to aid entry of the material to be cut into the flail head.

**WARNING:** Raising the front hood increases the possibility of debris escaping – never operate the machine with the front hood set any higher than is absolutely necessary.

## HEDGE CUTTING – Downward Cutting

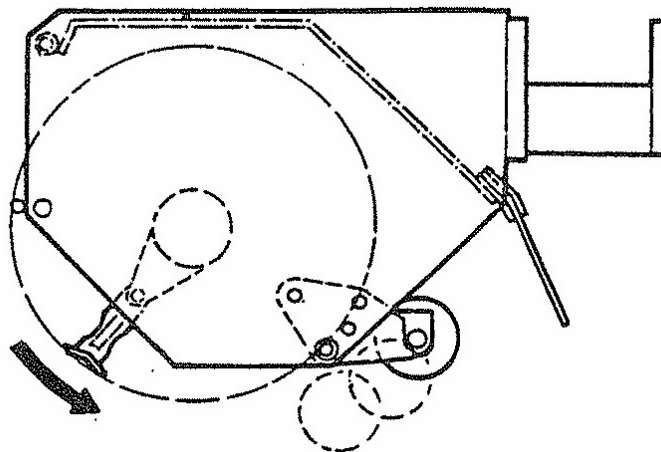

Where the size of the material to be cut makes it necessary for the front hood and carrier plates to be removed to allow the rotor to cut, the rotor must always be set to cut with downwards rotation – this results in a poorer finish to the work and demands higher power requirement.

The roller should be set slightly higher than the rotor – i.e. in position 1 as shown on the previous roller position page.

The rear flap must always remain in position to deflect the cut material downwards into the hedge. Because of the tendency to eject material out of the rear of the hood when downward cutting it is important that the rear flap is kept in good condition and replaced if excessive worn or damaged.

**WARNING:** Do not remove guarding under any circumstances during operation.



## TRACTOR FORWARD SPEED

---

The material being cut determines tractor forward speed. Forward speed can be as fast as that which allows the flail head sufficient time to cut the vegetation properly. Too fast a speed will be indicated by over frequent operation of the breakaway system, a fall off in tractor engine revs and a poor finish to the work leaving ragged uncut tufts and poorly mulched cuttings.

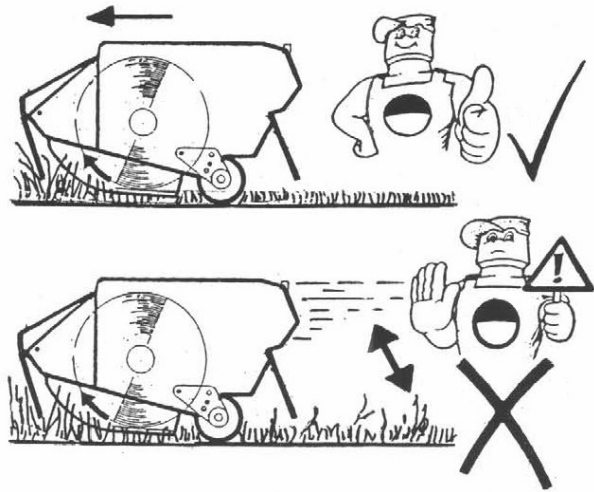

# HEDGECUTTING PROCEDURE



## WARNING!

**Never cut on the blind side of the hedge**

It is impossible to see potential hazards or dangers and the position of the flail head may allow debris to be propelled through the hedge towards the tractor and the operator.

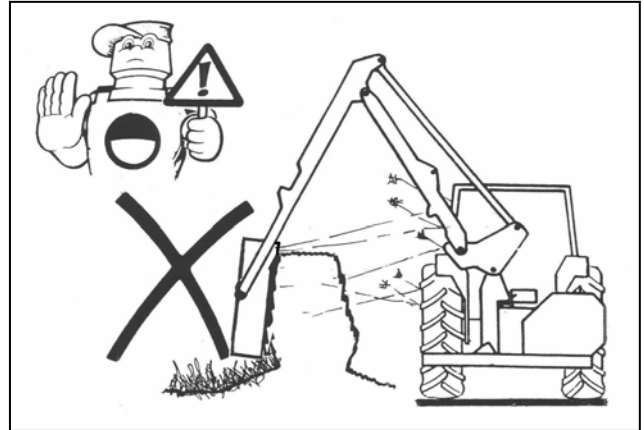

Cut the side and bottom of the field side first. This leaves the maximum thickness of hedge on the road side to prevent the possibility of debris being thrown through the hedge into the path of oncoming vehicles.

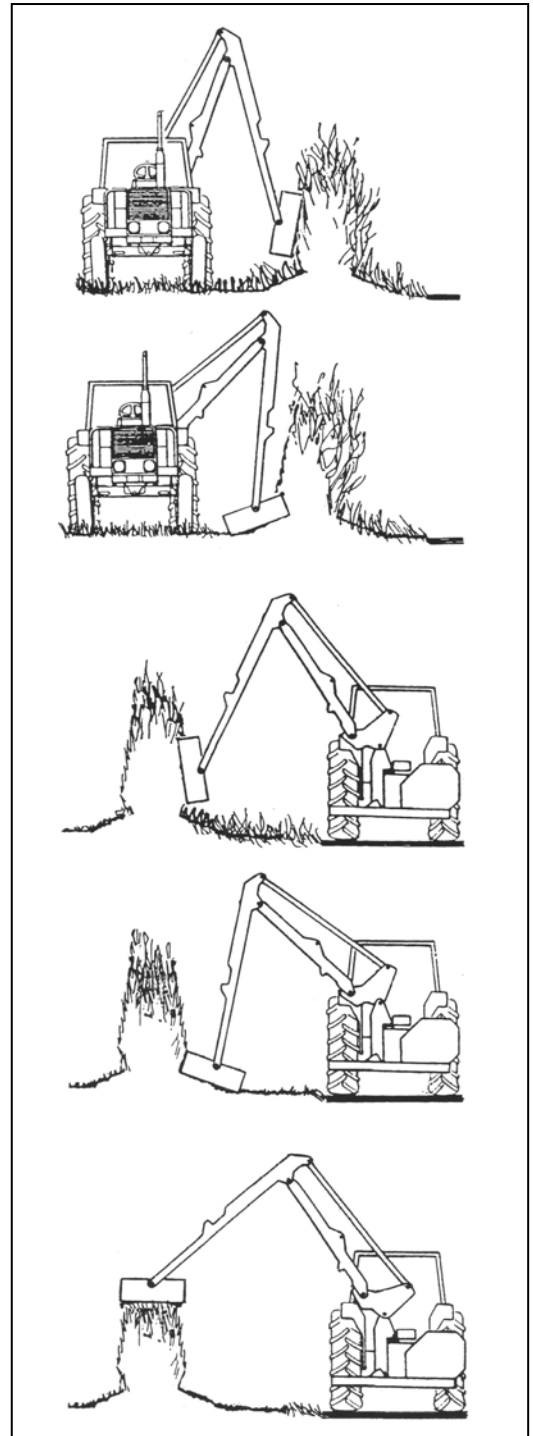

Cut the side and bottom of the road side.

Top cut the hedge to the height required.

## WIRE TRAP

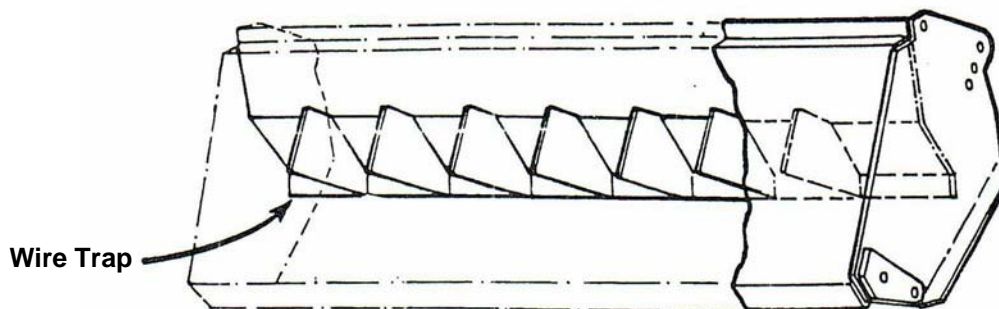

The flailhead is equipped with a 'wire cutting' edge welded into the underside – this plate should not be interfered with in any way. If wire becomes caught in the rotor the machine must be switched off immediately and the wire removed.

### Removing Wire

Select 'Rotor Off' and wait until the rotor has stopped turning completely. Switch off the tractor and remove the starting key before attempting to remove the wire.

**WARNING:** Do not reverse the rotor in an attempt to unwind the wire.

## MAINTENANCE

Frequently inspect the rotor assembly for damaged or missing flails – Never operate or attempt to run the rotor with flails missing, imbalance will cause severe vibration and can rapidly damage the rotor shaft bearings. As an emergency measure, if a flail is broken off or missing, removal of an opposing flail on the opposite side of the rotor will retain the balance. Replace the flails at the earliest possible opportunity and always replace in opposite pairs. Never match up a new flail with a sharpened or damaged flail as the latter will be lighter thus causing imbalance of the rotor.

Blunt flails absorb more power and leave an untidy finish to the work. They should be sharpened on a grindstone or with a portable grinder periodically. Always wear protective gear when sharpening flails.

### IMPORTANT

On the first day of use with a new flailhead, nuts should be checked for tightness every hour and retightened if required. Thereafter they should be checked on a daily basis prior to use of the machine.

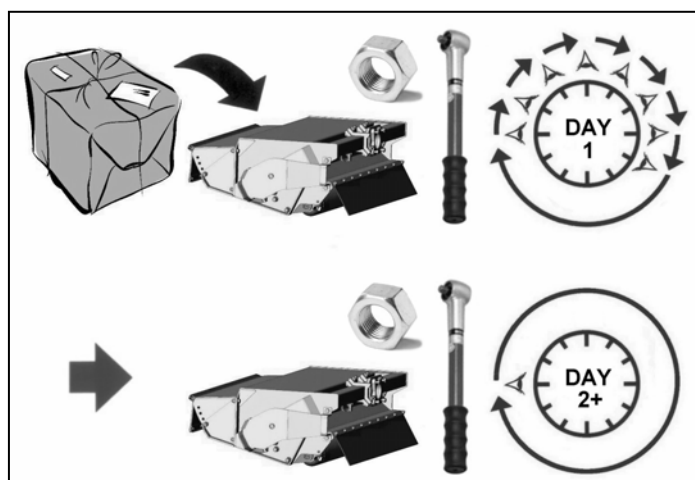

### Lubrication



Grease lubrication points daily.



## McConnel Generic Parts Manual

*Generic parts manuals should be used as a general guide to the components used on the machine; to ensure accurate parts information for a specific machine please refer to the 'Interactive Parts Database' on our website which identifies the exact components used on the machine when it was manufactured based on the machine's unique serial number.*

*Direct access can be gained using the web address or QR code below.*  
<http://www.mcconnel.com/support/product-support/interactive-parts-database/>

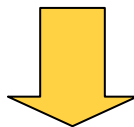

*Design improvements may have altered some of the parts listed in this manual; latest parts will always be supplied if they are interchangeable with earlier ones.*

# FLAILHEAD – MAIN ASSEMBLY

Module:  
7490951 – L/H Build

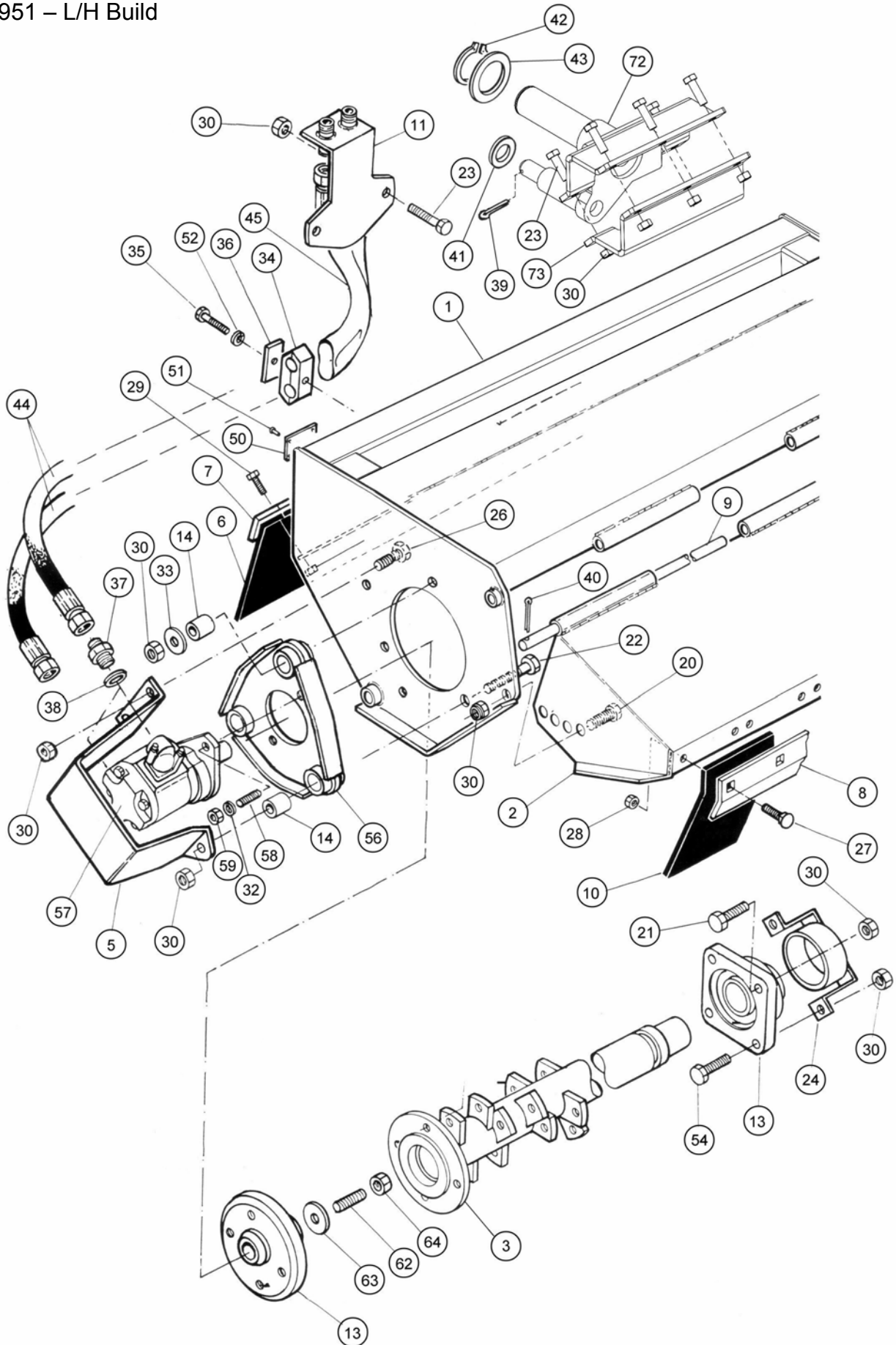

**FLAILHEAD – MAIN ASSEMBLY**

REF.	QTY.	PART No.	DESCRIPTION
		<b>7490951</b>	<b>0.9m SLIDING FLAILHEAD - L/H Build</b>
1	1	41282.10	CASING - Sliding L/H Build
2	1	41283.01	FRONT HOOD
3	1	41284.03	ROTOR - 900mm
4	2	41285.01	ROLLER BRACKET <i>(not illustrated)</i>
5	1	41288.01	MOTOR COVER
6	1	41289.01	REAR FLAP
7	1	41290.01	CLAMP STRIP - REAR
8	1	41291.01	CLAMP STRIP - FRONT
9	1	41293.01	HOOD PIVOT BAR
10	6	41296.01	FRONT FLAP
11	1	41297.01	HOSE BRACKET
12	1	41301.01	ROLLER ASSEMBLY <i>(not illustrated)</i>
13	1	03.008.01	BEARING ASSEMBLY
14	3	03.871.01	RUBBER BUSH
15	48	02.801.01	COLLAR <i>(not illustrated)</i>
16	24	05.775.02	BOLT <i>(not illustrated)</i>
17	24	05.895.01	FORGED SHACKLE <i>(not illustrated)</i>
18	48	7190463	FLAIL <i>(not illustrated)</i>
19	24	02.807.01	SPACER <i>(not illustrated)</i>
20	2	9313046	BOLT
21	2	9313066	BOLT
22	3	9213136	BOLT
23	6	9313086	BOLT
24	1	06.037.01	BEARING COVER
25	28	05.968.02	SELF-LOCKING NUT
26	2	9313056	BOLT
27	12	9293054	BOLT
28	22	9143004	CLEVELOK NUT
29	8	9313034	BOLT
30	18	9143006	CLEVELOK NUT
31	4	9113008	NUT
32	2	9100208	SPRING WASHER
33	3	02.824.01	WASHER
34	2	06.430.09	DOUBLE HOSE CLAMP
35	1	9213094	BOLT
36	1	06.418.03	CLAMP PLATE
37	2	8581270	ADAPTOR
38	2	8650106	BONDED SEAL
39	1	9501406	COTTER PIN
40	1	9501325	SPLIT PIN
41	1	0100109	FLAT WASHER
42	1	0406247	EXTERNAL CIRCLIP
43	1	1090037	RETAINING WASHER

# FLAILHEAD – MAIN ASSEMBLY

Module:  
7490951 – L/H Build

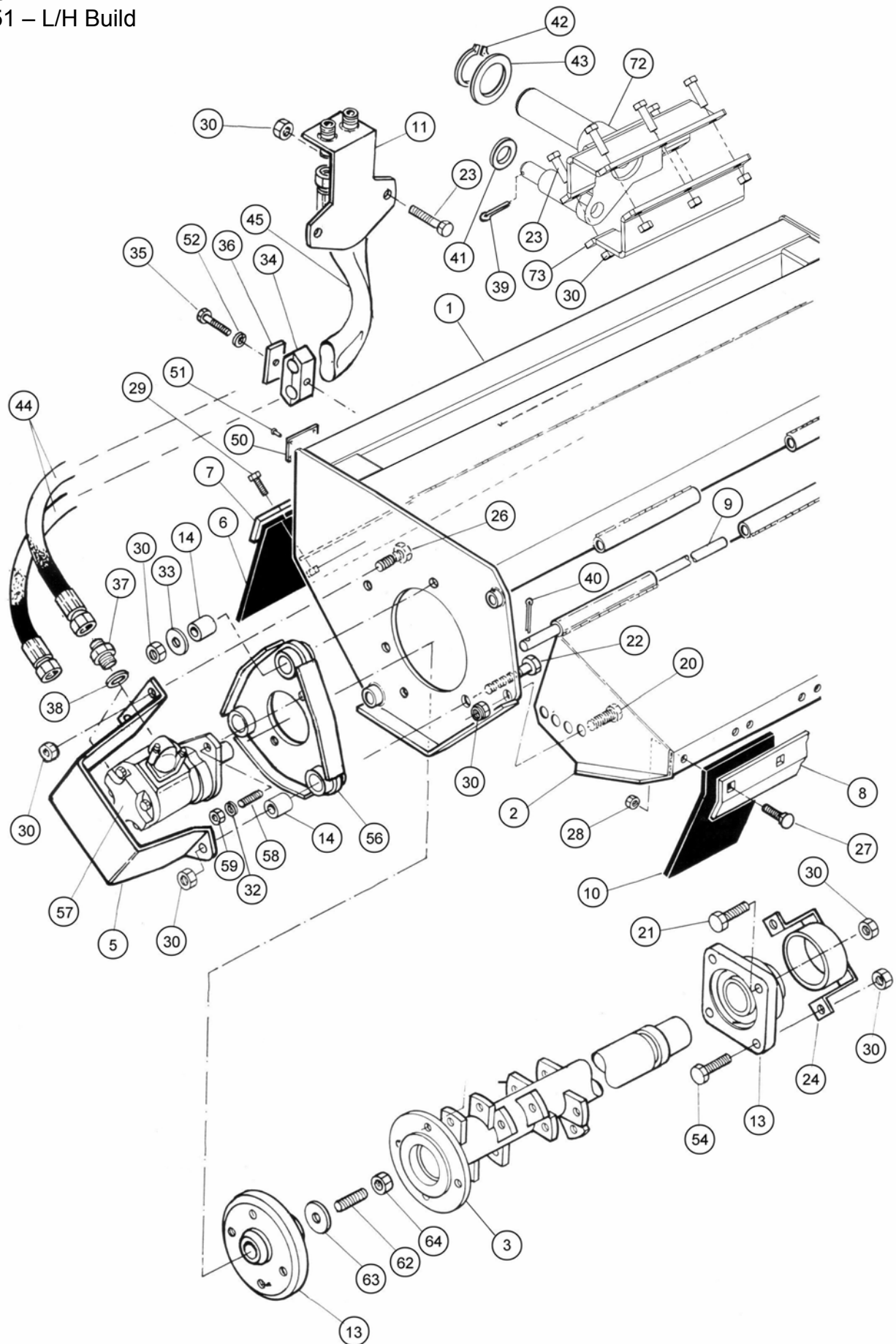

**FLAILHEAD – MAIN ASSEMBLY**

REF.	QTY.	PART No.	DESCRIPTION
44	2	8501247	HOSE - 5/8" BSP FS/FS x 43"
45	1	42374.10	HOSE SLEEVING
46	1	1290255	DECAL
47	1	1290341	DECAL
48	1	1290377	DECAL
49	1	1290392	DECAL
50	1	1335246	SERIAL No. PLATE
51	4	7103230	POP RIVET
52	1	9100204	SPRING WASHER
53	1	9100206	SPRING WASHER
54	3	9313076	BOLT
55	1	42603.01	MOTOR MOUNTING ASSEMBLY
	1	42603.02	MOTOR MOUNTING ASSEMBLY
56	1	09.132.01	MOTOR MOUNTING PLATE
57	1	08.785.04	MOTOR - <i>Applicable to 42603.01</i>
		08.785.05	MOTOR - <i>Applicable to 42603.02</i>
58	2	04.282.56	STUD
59	2	9113005	PLAIN NUT
60	2	9100205	SPRING WASHER
61	1	03.833.01	MOTOR DRIVE PLATE
62	1	03.960.02	STUD
63	1	03.959.02	WASHER
64	1	0141003	CLEVELOK NUT
65	4	03.917.01	STUD
66	1	7114481	DECAL
67	2	9100305	INTERNAL SERRATED WASHER
68	1	21874.02	CLAMP BAR - SHORT
69	1	21874.01	CLAMP BAR - LONG
70	1	9213204	BOLT
71	1	9213284	BOLT
72	1	21872.01	HEAD BRACKET
73	1	21873.01	CLAMP PLATE
		<b>08.785.02</b>	<b>SEAL KIT</b>

**\*(Option) Quick coupler set:**

**57234**            **Flate face coupler W**  
**57235**            **Flate face coupler M**



**MOTOR MOUNTING ASSEMBLY**

**Modules:**

42603.01

42603.02 (*illustrated*)

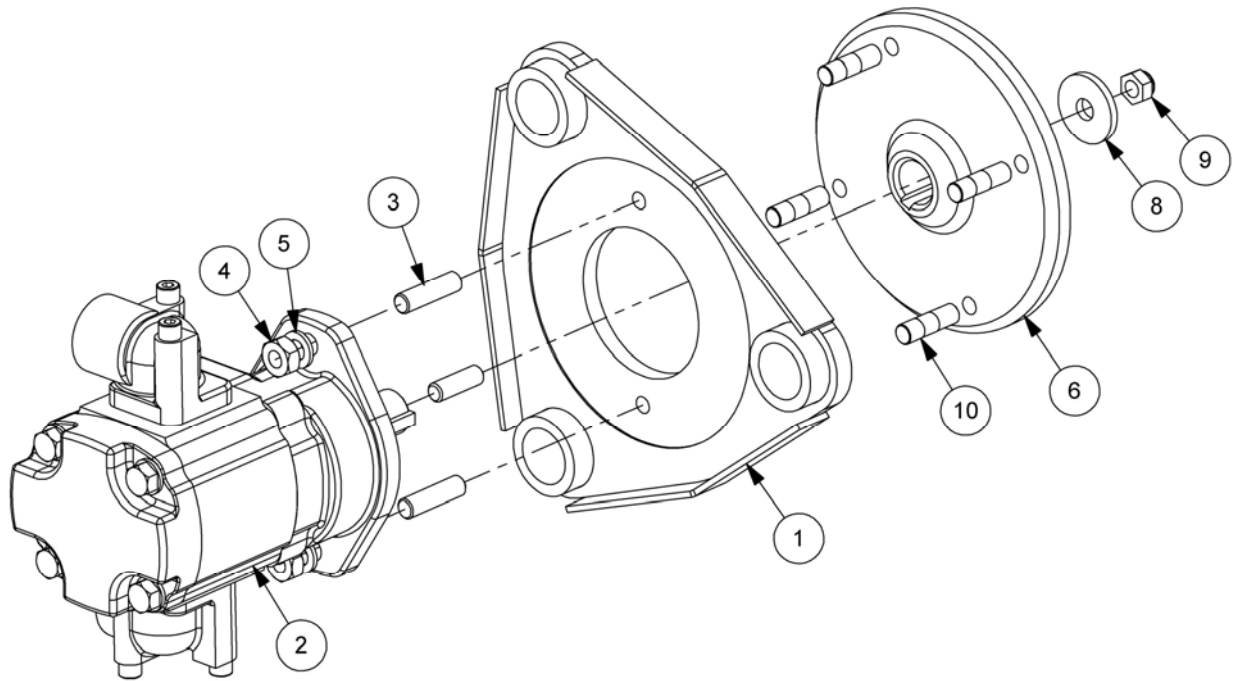



**MOTOR MOUNTING ASSEMBLY**

REF.	QTY.	PART No.	DESCRIPTION
		<b>42603.01</b>	<b>MOTOR MOUNTING ASSEMBLY</b>
		<b>42603.02</b>	<b>MOTOR MOUNTING ASSEMBLY</b>
1	1	09.132.01	MOTOR MOUNTING PLATE
2	1	8301308	<b>Motor with drainline</b>
3	2	04.282.56	STUD
4	2	9113005	PLAIN NUT
5	2	9100205	SPRING WASHER
6	1	03.833.01	MOTOR DRIVE PLATE
7	1	03.960.02	STUD
8	1	03.959.02	WASHER
9	1	0141003	CLEVELOK NUT
10	4	03.917.01	STUD

**ROTOR ASSEMBLY**

Module:  
41284.01 - Rotor

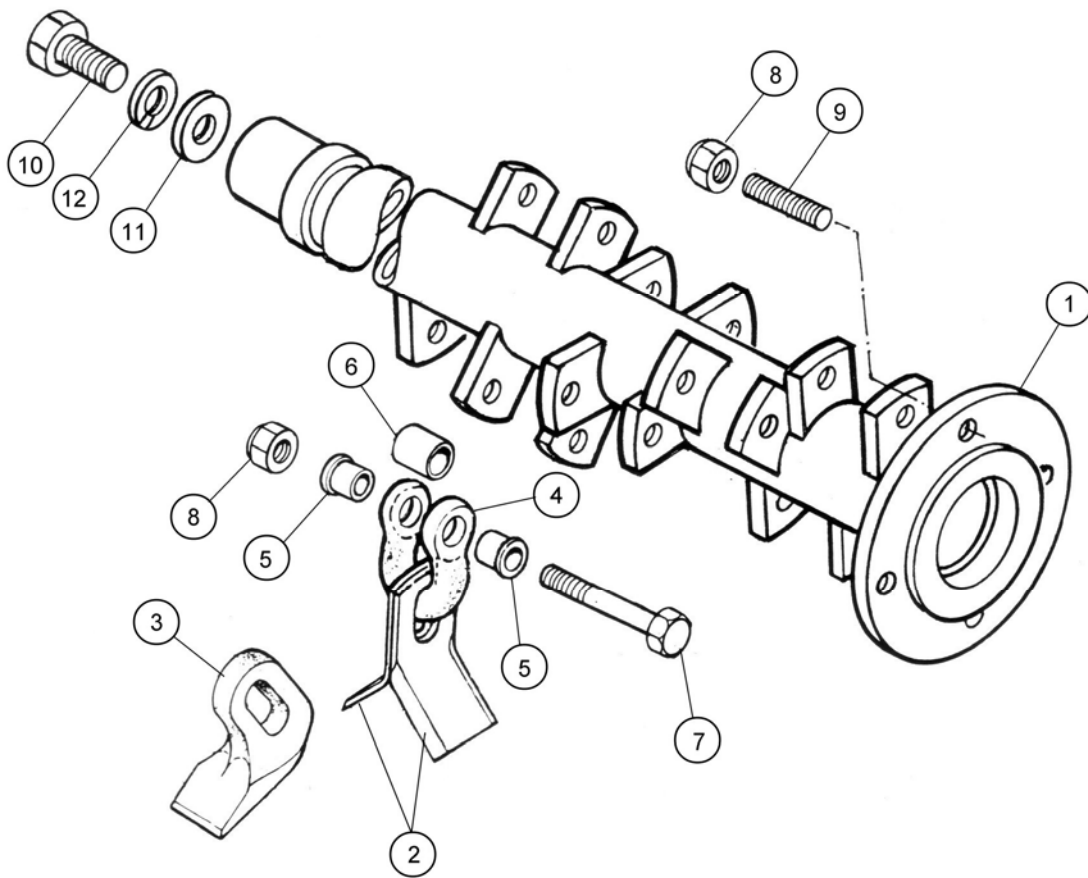

REF.	QTY.	PART No.	DESCRIPTION
			<b>0.9M ROTOR ASSEMBLY</b>
1	1	41284.01	ROTOR
2	48	7190166	FLAIL - GRASS
3	24	7190463	FLAIL - UNIVERSAL
4	24	05.895.01	SHACKLE
5	48	02.801.01	COLLAR
6	24	02.807.01	SPACER
7	24	05.775.02	BOLT
8	28	05.968.02	SELF-LOCKING NUT
9	4	03.917.01	STUD
10	1	9313076	SETScrew
11	1	02.824.01	SPECIAL WASHER
12	1	9100206	SPRING WASHER

**ROLLER ASSEMBLY**

**Module:**  
41301.01 – Roller Assembly

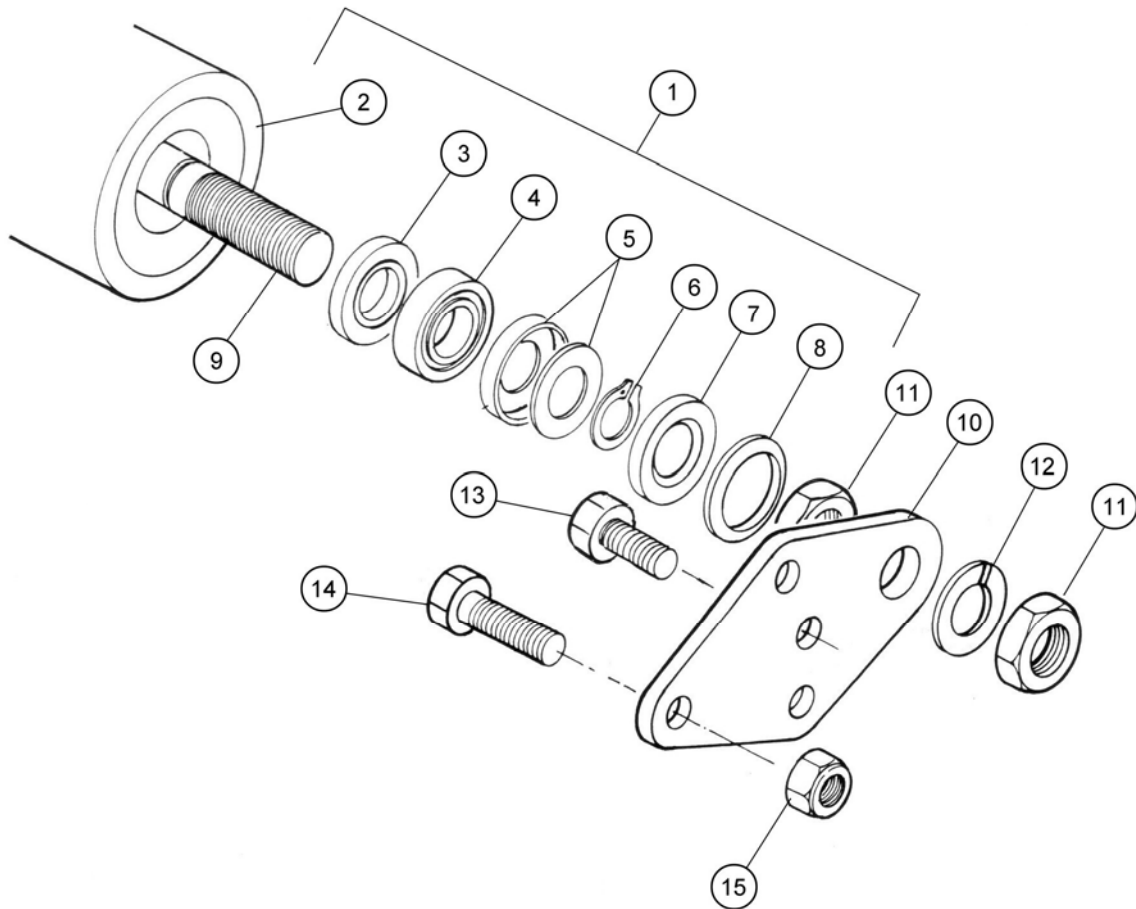

REF.	QTY.	PART No.	DESCRIPTION
			<b>0.9M ROLLER ASSEMBLY</b>
1		41301.01	ROLLER ASSEMBLY - <i>Comprising of:</i>
2		41301.31	ROLLER
3		04.456.07	SEAL
4		04.456.11	BEARING
5		04.456.06	LABYRINTH SEAL
6		04.456.04	EXTERNAL CIRCLIP
7		04.456.08	V SEAL
8		04.456.05	BEARING RETAINER
9		41301.32	ROLLER SHAFT
10		41285.01	ROLLER BRACKET
11		9113008	PLAIN NUT
12		9100208	SPRING WASHER
13		9313066	SETSCREW
14		9313086	SETSCREW
15		9143006	SELF-LOCKING NUT

# 0.9M ROLLER ASSEMBLY

**McCONEL**

Module(s): 22562.24 (Rev. A)

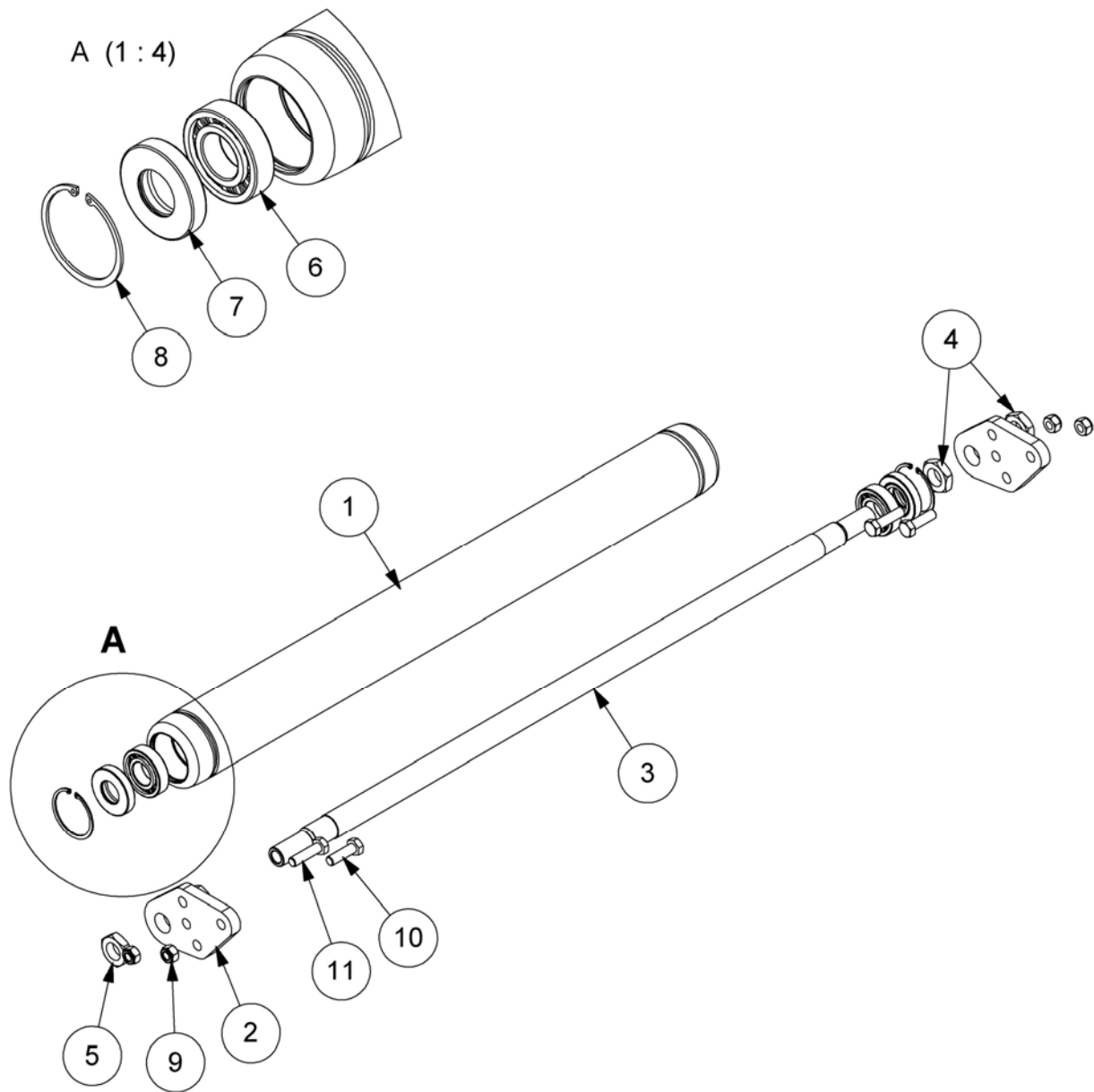

ITEM NO.	PART NUMBER	DESCRIPTION	QTY.
1	22562.25	0.9M ROLLER	1
2	41285.08	ROLLER BRK	2
3	22562.26	0.9M LIGHTWEIGHT ROLLER SHAFT.	1
4	0131039	LH LOCKNUT	2
5	0131009	UNF LOCKNUT	2
6	0600100	BEARING DEEP GROOVE	2
7	8629250	SHAFT SEAL	2
8	0411262	INT CIRCLIP	2
9	9163006	NYLOC NUT	4
10	9213086	BOLT	2
11	9213096	BOLT	2

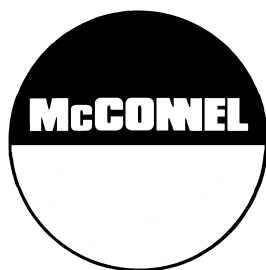

McConnel Limited, Temeside Works, Ludlow, Shropshire SY8 1JL. England.  
Telephone: 01584 873131. Facsimile: 01584 876463. [www.mcconnel.com](http://www.mcconnel.com)