

Publication 721
September 2012
Part No. 22675.21
Revised: 13.01.14



McCONEL

ROBOGRIND

STUMP GRINDER ATTACHMENT

Operator & Parts Manual

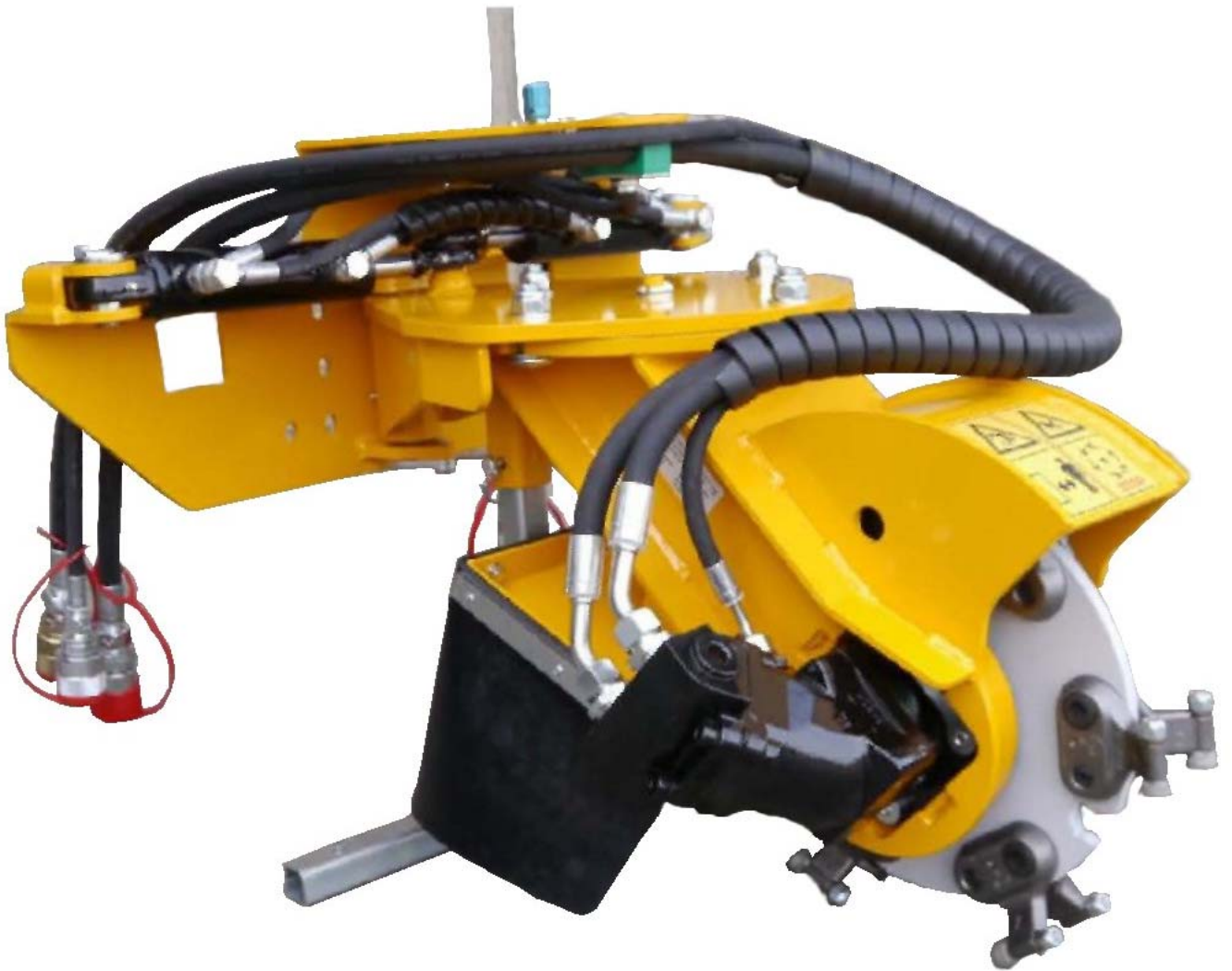

IMPORTANT

VERIFICATION OF WARRANTY REGISTRATION



DEALER WARRANTY INFORMATION & REGISTRATION VERIFICATION

It is imperative that the selling dealer registers this machine with McConnel Limited before delivery to the end user – failure to do so may affect the validity of the machine warranty.

To register machines go to the McConnel Limited web site at www.mcconnel.com, log onto 'Dealer Inside' and select the 'Machine Registration button' which can be found in the Service Section of the site. Confirm to the customer that the machine has been registered in the section below.

Should you experience any problems registering a machine in this manner please contact the McConnel Service Department on 01584 875848.

Registration Verification

Dealer Name:
Dealer Address:
Customer Name:
Date of Warranty Registration:/...../..... Dealer Signature:

NOTE TO CUSTOMER / OWNER

Please ensure that the above section above has been completed and signed by the selling dealer to verify that your machine has been registered with McConnel Limited.

IMPORTANT: During the initial 'bedding in' period of a new machine it is the customer's responsibility to regularly inspect all nuts, bolts and hose connections for tightness and re-tighten if required. New hydraulic connections occasionally weep small amounts of oil as the seals and joints settle in – where this occurs it can be cured by re-tightening the connection – *refer to torque settings chart below*. The tasks stated above should be performed on an hourly basis during the first day of work and at least daily thereafter as part of the machines general maintenance procedure.

CAUTION: DO NOT OVER TORQUE HYDRAULIC FITTINGS AND HOSES

TORQUE SETTINGS FOR HYDRAULIC FITTINGS

HYDRAULIC HOSE ENDS		
BSP	Setting	Metric
1/4"	18 Nm	19 mm
3/8"	31 Nm	22 mm
1/2"	49 Nm	27 mm
5/8"	60 Nm	30 mm
3/4"	80 Nm	32 mm
1"	125 Nm	41 mm
1.1/4"	190 Nm	50 mm
1.1/2"	250 Nm	55 mm
2"	420 Nm	70 mm

PORT ADAPTORS WITH BONDED SEALS		
BSP	Setting	Metric
1/4"	34 Nm	19 mm
3/8"	47 Nm	22 mm
1/2"	102 Nm	27 mm
5/8"	122 Nm	30 mm
3/4"	149 Nm	32 mm
1"	203 Nm	41 mm
1.1/4"	305 Nm	50 mm
1.1/2"	305 Nm	55 mm
2"	400 Nm	70 mm

WARRANTY POLICY

WARRANTY REGISTRATION

All machines must be registered, by the selling dealer with McConnel Ltd, before delivery to the end user. On receipt of the goods it is the buyer's responsibility to check that the Verification of Warranty Registration in the Operator's Manual has been completed by the selling dealer.

1. LIMITED WARRANTIES

- 1.01. *All machines supplied by McConnel Ltd are warranted to be free from defects in material and workmanship from the date of sale to the original purchaser for a period of 12 months, unless a different period is specified.*
- 1.02. *All spare parts supplied by McConnel Ltd and purchased by the end user are warranted to be free from defects in material and workmanship from the date of sale to the original purchaser for a period of 6 months. All parts warranty claims must be supported by a copy of the failed part invoice to the end user. We cannot consider claims for which sales invoices are not available.*
- 1.03. *The warranty offered by McConnel Ltd is limited to the making good by repair or replacement for the purchaser any part or parts found, upon examination at its factory, to be defective under normal use and service due to defects in material or workmanship. Returned parts must be complete and unexamined. Pack the component(s) carefully so that any transit damage is avoided. All ports on hydraulic items should be drained of oil and securely plugged to prevent seepage and foreign body ingress. Certain other components, electrical items for example, may require particular care when packing to avoid damage in transit.*
- 1.04. *This warranty does not extend to any product from which McConnel Ltd's serial number plate has been removed or altered.*
- 1.05. *This warranty does not apply to any part of the goods, which has been subjected to improper or abnormal use, negligence, alteration, modification, fitment of non-genuine parts, accident damage, or damage resulting from contact with overhead power lines, damage caused by foreign objects (e.g. stones, iron, material other than vegetation), failure due to lack of maintenance, use of incorrect oil or lubricants, contamination of the oil, or which has served its normal life. This warranty does not apply to any expendable items such as blades, belts, clutch linings, filter elements, flails, flap kits, skids, soil engaging parts, shields, guards, wear pads, pneumatic tyres or tracks.*
- 1.06. *Temporary repairs and consequential loss - i.e. oil, downtime and associated parts are specifically excluded from the warranty.*
- 1.07. *Warranty on hoses is limited to 12 months and does not include hoses which have suffered external damage. Only complete hoses may be returned under warranty, any which have been cut or repaired will be rejected.*
- 1.08. *Machines must be repaired immediately a problem arises. Continued use of the machine after a problem has occurred can result in further component failures, for which McConnel Ltd cannot be held liable, and may have safety implications.*
- 1.09. *If in exceptional circumstances a non McConnel Ltd part is used to effect a repair, warranty reimbursement will be at no more than McConnel Ltd's standard dealer cost for the genuine part.*
- 1.10. *Except as provided herein, no employee, agent, dealer or other person is authorised to give any warranties of any nature on behalf of McConnel Ltd.*
- 1.11. *For machine warranty periods in excess of 12 months the following additional exclusions shall apply:*
 - 1.11.1. *Hoses, exposed pipes and hydraulic tank breathers.*
 - 1.11.2. *Filters.*
 - 1.11.3. *Rubber mountings.*
 - 1.11.4. *External electric wiring.*
 - 1.11.5. *Bearings and seals.*

- 1.12. *All service work, particularly filter changes, must be carried out in accordance with the manufacturer's service schedule. Failure to comply will invalidate the warranty. In the event of a claim, proof of the service work being carried out may be required.*
- 1.13. *Repeat or additional repairs resulting from incorrect diagnosis or poor quality previous repair work are excluded from warranty.*

NB Warranty cover will be invalid if any non-genuine parts have been fitted or used. Use of non-genuine parts may seriously affect the machine's performance and safety. McConnel Ltd cannot be held responsible for any failures or safety implications that arise due to the use of non-genuine parts.

2. REMEDIES AND PROCEDURES

- 2.01. *The warranty is not effective unless the Selling Dealer registers the machine, via the McConnel Ltd web site and confirms the registration to the purchaser by completing the confirmation form in the operator's manual.*
- 2.02. *Any fault must be reported to an authorised McConnel Ltd dealer as soon as it occurs. Continued use of a machine, after a fault has occurred, can result in further component failure for which McConnel Ltd cannot be held liable.*
- 2.03. *Repairs should be undertaken within two days of the failure. Claims submitted for repairs undertaken more than 2 weeks after a failure has occurred, or 2 days after the parts were supplied will be rejected, unless the delay has been authorised by McConnel Ltd. Please note that failure by the customer to release the machine for repair will not be accepted as a reason for delay in repair or submitting warranty claims.*
- 2.04. *All claims must be submitted, by an authorised McConnel Ltd Service Dealer, within 30 days of the date of repair.*
- 2.05. *Following examination of the claim and parts, McConnel Ltd will pay, at their discretion, for any valid claim the invoiced cost of any parts supplied by McConnel Ltd and appropriate labour and mileage allowances if applicable.*
- 2.06. *The submission of a claim is not a guarantee of payment.*
- 2.07. *Any decision reached by McConnel Ltd is final.*

3. LIMITATION OF LIABILITY

- 3.01. *McConnel Ltd disclaims any express (except as set forth herein) and implied warranties with respect to the goods including, but not limited to, merchantability and fitness for a particular purpose.*
- 3.02. *McConnel Ltd makes no warranty as to the design, capability, capacity or suitability for use of the goods.*
- 3.03. *Except as provided herein, McConnel Ltd shall have no liability or responsibility to the purchaser or any other person or entity with respect to any liability, loss, or damage caused or alleged to be caused directly or indirectly by the goods including, but not limited to, any indirect, special, consequential, or incidental damages resulting from the use or operation of the goods or any breach of this warranty. Notwithstanding the above limitations and warranties, the manufacturer's liability hereunder for damages incurred by the purchaser or others shall not exceed the price of the goods.*
- 3.04. *No action arising out of any claimed breach of this warranty or transactions under this warranty may be brought more than one (1) year after the cause of the action has occurred.*

4. MISCELLANEOUS

- 4.01. *McConnel Ltd may waive compliance with any of the terms of this limited warranty, but no waiver of any terms shall be deemed to be a waiver of any other term.*
- 4.02. *If any provision of this limited warranty shall violate any applicable law and is held to be unenforceable, then the invalidity of such provision shall not invalidate any other provisions herein.*
- 4.03. *Applicable law may provide rights and benefits to the purchaser in addition to those provided herein.*



For Safety and Performance...

ALWAYS READ THIS BOOK FIRST

McCONEL LIMITED

**Temeside Works
Ludlow
Shropshire
England**

**Telephone: 01584 873131
www.mcconnel.com**

NOISE STATEMENT

The equivalent daily personal noise exposure from this machine measured at the operators' ear is within the range 78 – 85 dB, these figures apply to a normal distribution of use where the noise fluctuates between zero and maximum. The figures assume that the machine is fitted to a tractor with a 'quiet' cab with the windows closed in a generally open environment. We recommend that the windows are kept closed. With the cab rear window open the equivalent daily personal noise exposure will increase to a figure within the range 82 – 88 dB. At an equivalent daily noise exposure level of 85 – 90 dB ear protection is recommended and must always be used if any window is left open.

EC DECLARATION OF CONFORMITY

Manufacturer:..... FSI power-tech aps
Erhvervsparken 2
DK 7160 Tørring
Phone +45 7580 5558

Authorized to prepare technical file: Mr. Henning Schmidt
Erhvervsparken 2
DK 7160 Tørring
Phone +45 7580 5558

Hereby declare that the product

Machine model: **ROBOGRIND**

Serial number:.....

Year of production: **2012**

Function: **Tree stump cutting**

Is in conformity with all relevant requirements of the Machinery Directive 2006/42/EC.

Denmark 24/8-2012

Signature: *H. Schmidt.*
Henning Schmidt, Director



Warranty is valid 12 month from delivery date, wear parts are not included.
Mounting unoriginal parts excludes warranty claims.

LIST OF CONTENTS

Page No.

Operator Section

General Information	1
Machine Description	2
Specifications	2
Safety Information	3
Safety Decals	6
Attachment	7
Operation	8
General Maintenance	9

Parts Section

Frame Module	11
Housing Module	13
Grinders Module	14
Protection Module	15
Hydraulic Module	16
Motor Module	17
Tool Kit	19

GENERAL INFORMATION

Always read this manual before attempting to operate the machine – whenever any doubt exists contact your dealer or the McConnel Service Department for advice and assistance.

Use only McConnel Genuine Service Parts on McConnel Equipment and Machines

DEFINITIONS – *The following definitions apply throughout this manual:*

WARNING

An operating procedure, technique etc., which –
can result in personal injury or loss of life if not observed carefully.

CAUTION

An operating procedure, technique etc., which –
can result in damage to either machine or equipment if not observed carefully.

NOTE

An operating procedure, technique etc., which is –
considered essential to emphasis.

LEFT AND RIGHT HAND

These terms are applicable to the machine when it is viewed from the rear facing forwards.

Note: The illustrations in this manual are for instructional purposes only and may on occasion not show some components in their entirety. In some instances an illustration may appear slightly different to that of your particular model but the general procedure will be the same. E&OA.

MACHINE & DEALER INFORMATION

Record the Serial Number of your machine on this page and always quote this number when ordering parts. Whenever information concerning the machine is requested remember also to state the make and model of tractor to which the machine is fitted.

Machine Serial Number:

Installation Date:

Machine Model details:

Dealer Name:

Dealer Address:

Dealer Telephone No:

Dealer Email Address:

MACHINE DESCRIPTION

The 'Robogrind' is a stump grinding attachment specifically designed for use on McConnell Robocut. The purpose of the machine is solely for use as a tree stump grinder. Never attempt to use the machine to perform a task it not designed for; this is dangerous to persons and will risk damage to machine and/or components.

SPECIFICATIONS

Weight	<i>92kg / 202.8lbs</i>
Cutter Wheel diameter (incl. teeth)	<i>370mm / 14½"</i>
Cutter Teeth (No.)	<i>12</i>
Cutting Wheel (speed)	<i>1800 rpm</i>
Maximum Pressure	<i>250 bar</i>
Maximum Flow	<i>45 l/min</i>





The following information in this section relates to a Robocut machine fitted with the Robogrind attachment.

Operators must read and fully understand the operating manuals for both machines before attempting to use this equipment.

This machine has the potential to be extremely dangerous - in the wrong hands it can kill or maim; It is therefore imperative that both owner and operator of the machine reads and understands the following section to ensure they are fully aware of the dangers that do, or may exist, and their responsibilities surrounding the use and operation of the machine.

The operator of this machine is responsible not only for their own safety but equally for the safety of others who may come into the close proximity of the machine, as the owner you are responsible for both.

When the machine is not in use it should be parked on a firm level site with the grinder resting on the ground and the starting key removed.

In the event of any fault being detected with the machine's operation it must be stopped immediately and not used again until the fault has been corrected by a qualified technician.

- *Before starting the machine the operator must read and understand all aspects of use and maintenance of the machine as stated in the specific operation manual.*
- *The machine must only be used by a responsible adult who is familiar with all aspects relating to safe operation.*
- *The machine must not be operated by children or non-authorized persons.*
- *Operators must know the meaning of all operation and safety decals on the machine, the attachment, and the remote control unit.*
- *Operators must know the procedure for switching the machine off normally and by using the Emergency Stop.*
- *Do not attempt to use the machine if the Emergency Stop switch is either damaged or malfunctioning.*

- *Never use the machine with safety guarding removed or defective.*
- *Operators should practice operation on flat open ground to familiarise themselves with driving and manoeuvring the machine before attempting to use it on sloping ground.*
- *Operators should practice manoeuvring the machine around obstacles without the grinder running before using the machine for work purposes.*
- *Never operate the machine when your vision is blocked by obstacles such as vehicles, buildings, hedges etc.; move to a position where you have an un-interrupted view of the machine.*
- *Never operate the machine standing directly in the line of travel.*
- *Do not use the machine on sand piles, gravel, or similar materials.*
- *Only operate the machine in good light conditions.*
- *Never run the machine in an enclosed area or building.*
- *Keep the machine clean to avoid build ups of dry materials that could ignite on hot components.*
- *Never stand directly below a machine that is operating or parked on a slope.*
- *Always operate the joystick control slowly; rapid or jerky movements can cause the machine to rear up causing loss of control.*
- *When operating the machine with the grinder running the operator must remain at least 5 metres away from the machine; always switch the grinder off before approaching it.*
- *When using the machine the operator should place themselves in a position that provides optimum visibility over the work area.*
- *Never leave a running machine unattended; always switch the engine off and remove the ignition key.*
- *Always stop and switch the machine off if persons or animals enter the work area, do not restart the machine until they are at a safe distance.*
- *Never use the machine to perform tasks it was not designed for.*
- *Never ride, or allow others to ride on the machine.*
- *Always inspect the work area prior to operation and remove stones, glass, metal, wire or any other foreign objects that are hazardous. Immovable hazards should be 'marked' so they can be avoided.*
- *Take extra care when operating the machine on slopes or uneven ground, there is increased risk of objects being thrown from the flail head when working in these conditions.*

- *The machine can be used on slopes of up to 50° (maximum) providing the surface is dry and firm.*
- *Should a machine overturn, a suitable crane or winch should be used to recover it, keep all persons at a safe distance before and during recovery.*
- *Do not operate the machine in foggy or frosty conditions as there is increased risk of accidents.*
- *Take extra care when working in close proximity to electrical cables; in some circumstances, operating the machine under overhead power lines can result in loss of radio signal causing the engine to deactivate.*
- *Do not operate the machine close to vehicles or properties where there is risk of damage by objects accidentally thrown from the grinder.*
- *It is the user's responsibility to protect persons in or near the work zone.*
- *When servicing or maintaining the machine no one should be allowed beneath it when it is raised unless it is securely supported on suitable ramps or stands.*
- *Never attempt to service or maintain the machine whilst it is running; always switch off the engine and remove the starting key.*
- *When transporting the machine on another vehicle or trailer the engine must be switched off and the machine chocked and secured using suitable ropes or chains.*
- *Check the condition of the cutting teeth and fixings on a regular basis; never use the machine with damaged/missing cutting teeth or loose fixings.*
- *Always clean the machine after use; care must be taken if the machine is hot. Never use solvent based chemicals for cleaning.*
- *When operating in excessively dusty conditions work may need to be interrupted on a regular basis to remove any build ups of dust on components that could cause overheating.*
- *Always press the Emergency Stop switch before refuelling.*
- *Wherever possible refuel the machine before work when the engine is cold. If refuelling during work, switch off the engine and allow it to cool before adding fuel.*
- *Test the Emergency Stop switch before each period of work to ensure it functions correctly.*
- *Never leave the machine, ignition key and control unit unattended where it could be started and used by un-authorized persons.*
- *Any inspection, service or maintenance of the flail head must only be performed with machine switched off and the starting key removed.*
- *Always wear safety gloves and glasses when performing service or maintenance on the cutting head.*
- *Grinder must always be switched off when manoeuvring outside of the work zone.*

SAFETY DECALS

Safety Decal Identification & Meaning



Read the manual first before using the machine.

Where any doubt exists contact the Dealer or Manufacturer before using the machine.



Safety distance 20 metres.

The operator must ensure that all persons remain at a safe distance from the machine.



Danger – Rotating Tool

Always stop the machine first before attempting any kind of maintenance



Wear ear and eye protection.

ATTACHMENT

Fit and secure the machine to the mounting frame on the front of the Robocut.

Connect up the hydraulic hoses and clearly mark them for future attachment. Ensure that the quick couplers are kept clean at all times to avoid dirt contamination.

Run the machine up to check it functions correctly. Never exceed the maximum hydraulic pressure.

Hydraulic oil and filters should be changed at the frequencies stated in the Robocut manual.

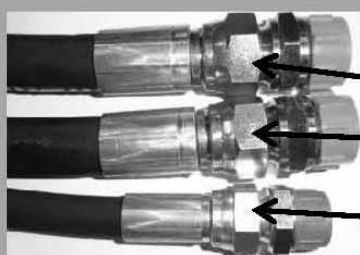
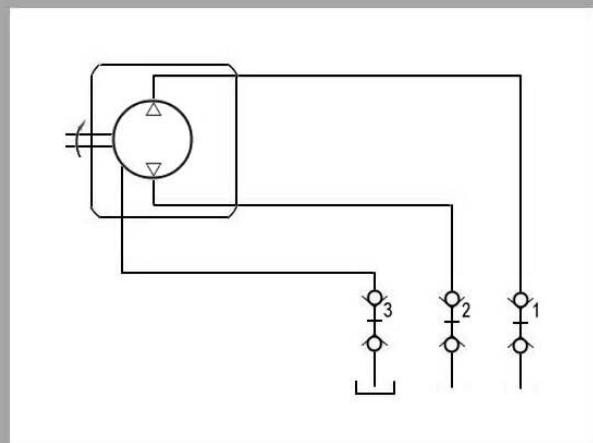
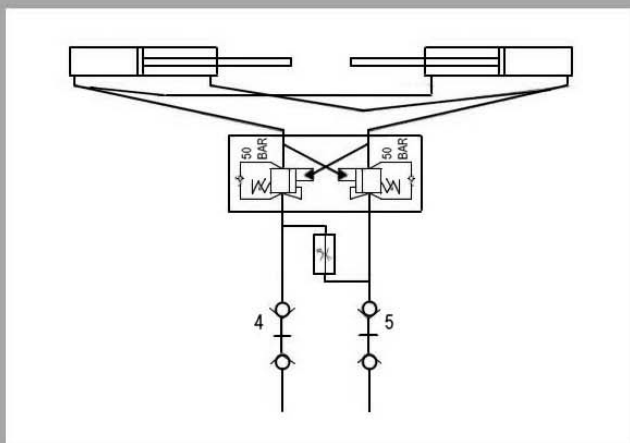

1. Pressure (Max 250 Bar, 45 l/min)
2. Return
3. Drain to tank (Pressure free max 3 Bar)

OPERATION

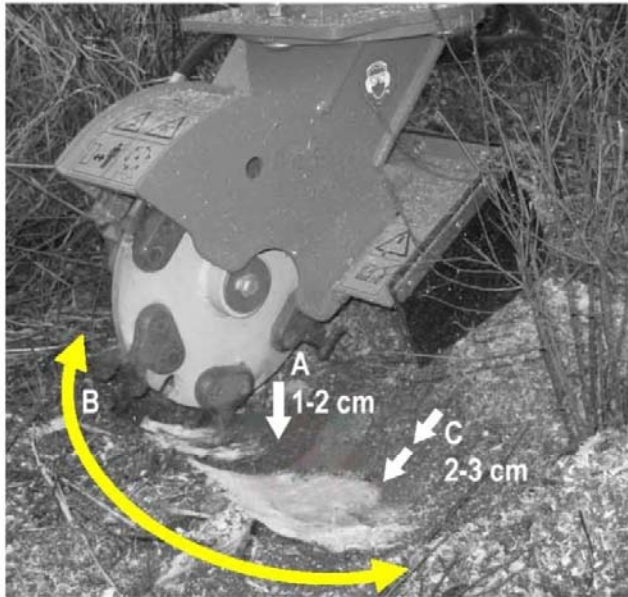

Start the cutter wheel above the stump.

A) Lower to cutting depth of 1-2 cm.

B) Swing to cut across the width of stump.

C) Move forwards and repeat operation.

Adjust swing speed to suit the task



DANGER ZONE
Operator or other persons must not enter this zone if the cutter wheel is running - stop the machine first.

GENERAL MAINTENANCE

Daily Maintenance

- Check nuts and bolts and retighten if required.
- Check safety guarding is in place and in full working order. If guards are damaged or missing do not use the machine until they have been repaired or replaced.
- Check cutting wheel components, any parts that are damaged, missing, or excessively worn should be replaced immediately before using the machine.
- Lubricate all grease points.
- Check hydraulic hoses and connections to ensure there are no leaks or signs of damage.

Grinding Teeth



Best results are achieved when the outer edges of the grinding teeth are sharp. The grinding teeth can be rotated to position a fresh sharp edge outermost (3 x 120°).

Torque Settings

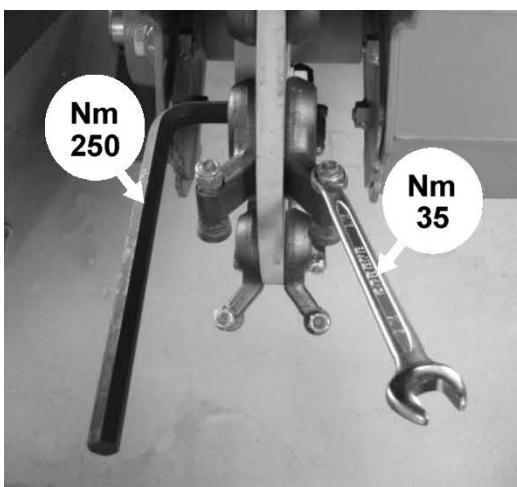

The correct torque settings for wear parts are shown opposite. When removing or replacing these components use the locking tool (Part Number 4001017) to lock the cutting wheel in position.



For best performance ...

USE ONLY GENUINE McCONEl SERVICE PARTS

*To be assured of the latest design improvements purchase your
'Genuine Replacements' from the 'Original Equipment Manufacturer'*

McCONEl LIMITED

Through your local Dealer or Stockist

Always quote:

- *Machine Type*
- *Serial Number*
- *Part Number*

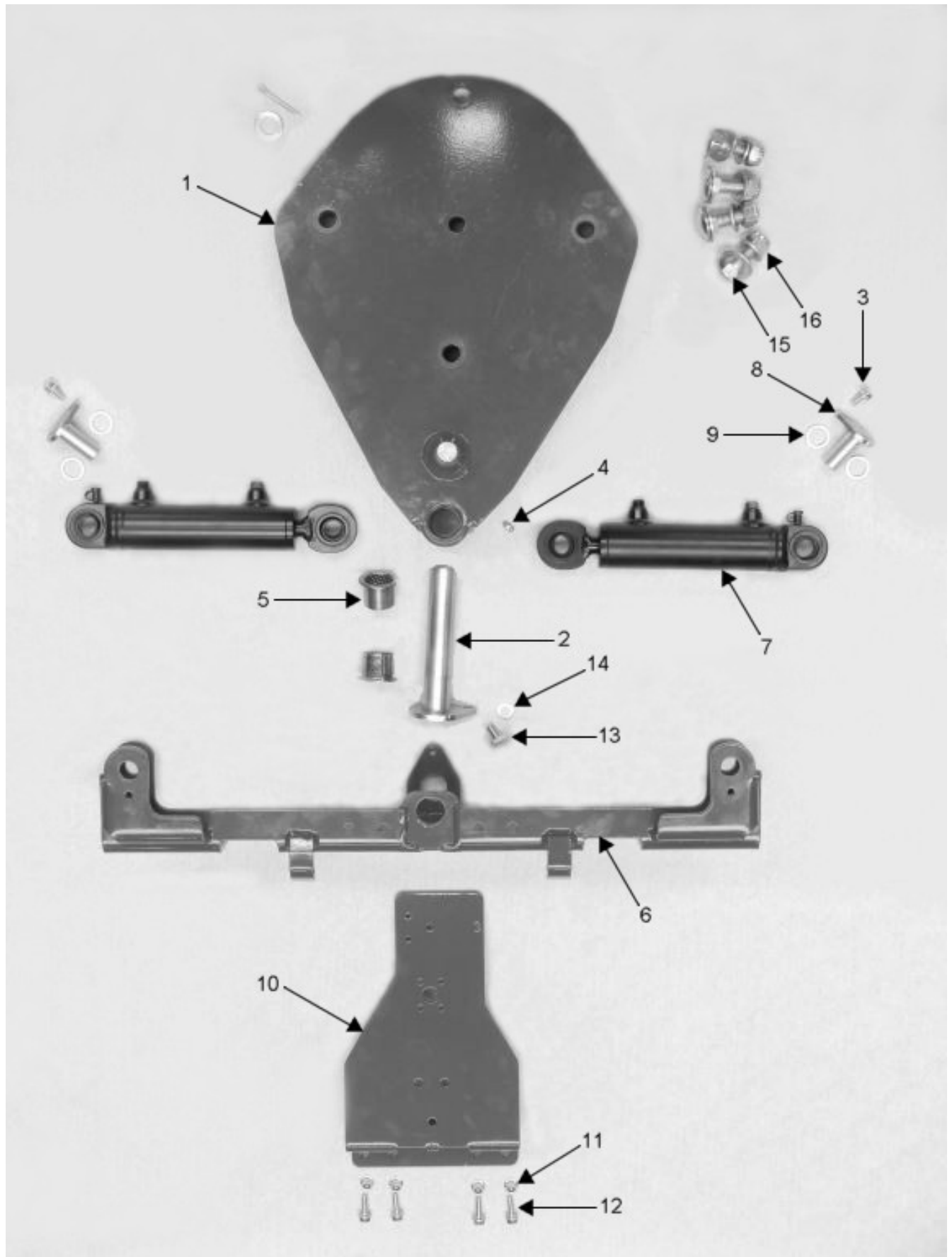

ROBOGRIND FRAME MODULE**McCONNEL**

Module(s): 4001701

REF.	QTY.	PART No.	DESCRIPTION
		4001701	FRAME MODULE
1	1	4001024	FRAME
2	1	4001025	BOLT
3	3	9313024	SETSCREW
4	1	4001026	GREASE NIPPLE
5	2	4001027	BUSH
6	1	4001028	MOUNTING FRAME
7	2	4001029	HYDRAULIC RAM
8	2	4001030	PIN
9	4	4001031	RING
10	1	4001032	FRAME BRACKET
11	4	9163004	NUT
12	4	9313064	SETSCREW
13	1	9313035	SETSCREW
14	1	9100105	WASHER
15	4	9313107	SETSCREW
16	4	9163007	LOCKNUT

Module(s): 4001702

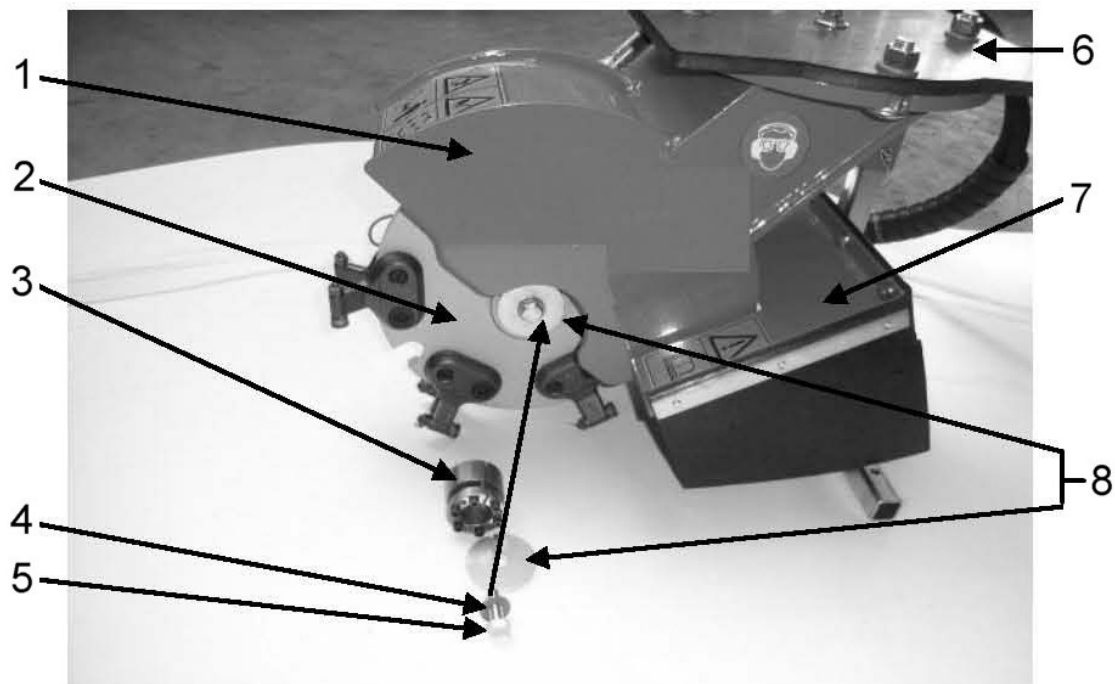

REF.	QTY.	PART No.	DESCRIPTION
		4001702	HOUSING MODULE
1	1	4001001	HOUSING
2	1	4001002	CUTTER WHEEL
3	1	4001003	CLAMPING ELEMENT
4	1	4001004	WASHER
5	1	4001005	SETSCREW
6	1	4001006	TOP PLATE
7	1	4001007	GUARD PLATE
8	1	4001008	WASHER

Module(s): 4001703

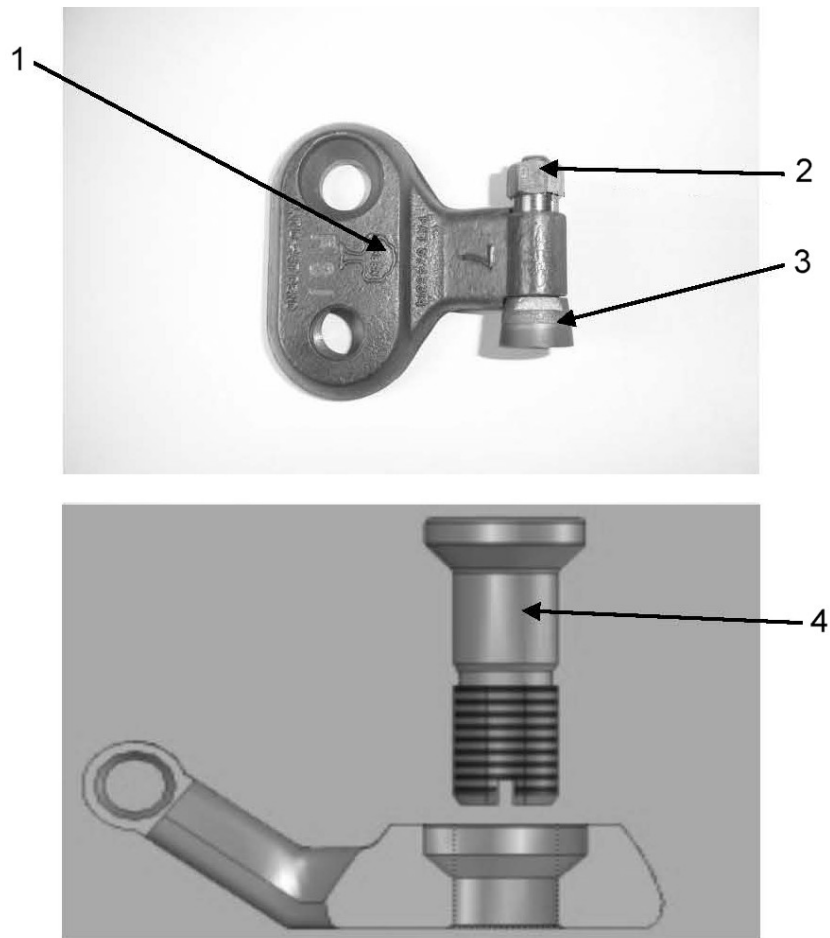

REF.	QTY.	PART No.	DESCRIPTION
		4001703	GRINDERS MODULE
1	12	4001020	POCKET
2	12	4001021	NUT
3	12	4001022	CUTTING TOOTH
4	12	4001023	BOLT

Module(s): 4001704

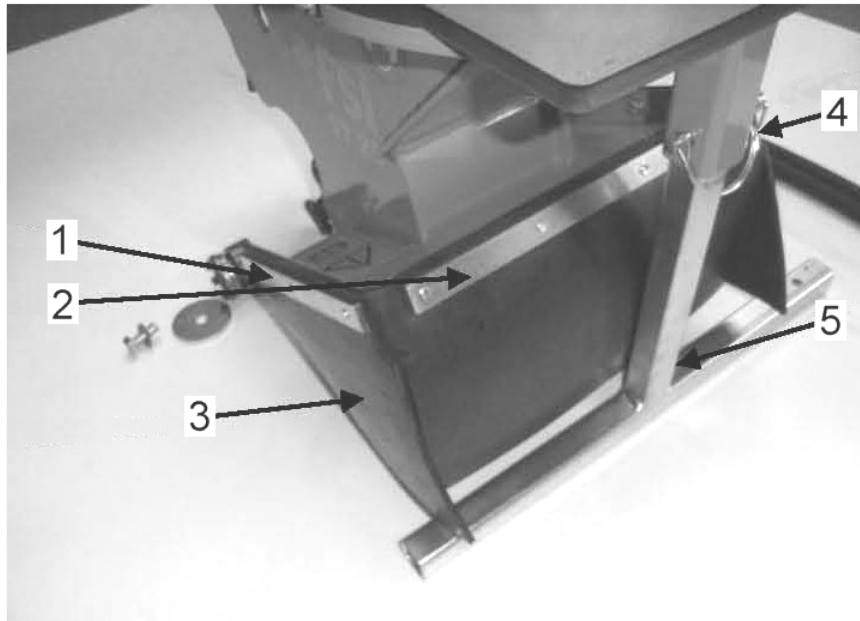

REF.	QTY.	PART No.	DESCRIPTION
		4001704	PROTECTION MODULE
1	2	4001012	CLAMP BAR
2	1	4001013	CLAMP BAR
3	1	4001014	RUBBER SHIELD
4	2	4001015	LOCK PIN
5	1	4001016	SUPPORT LEG

ROBOGRIND HYDRAULIC MODULE

McCONNEL

Module(s): 4001706

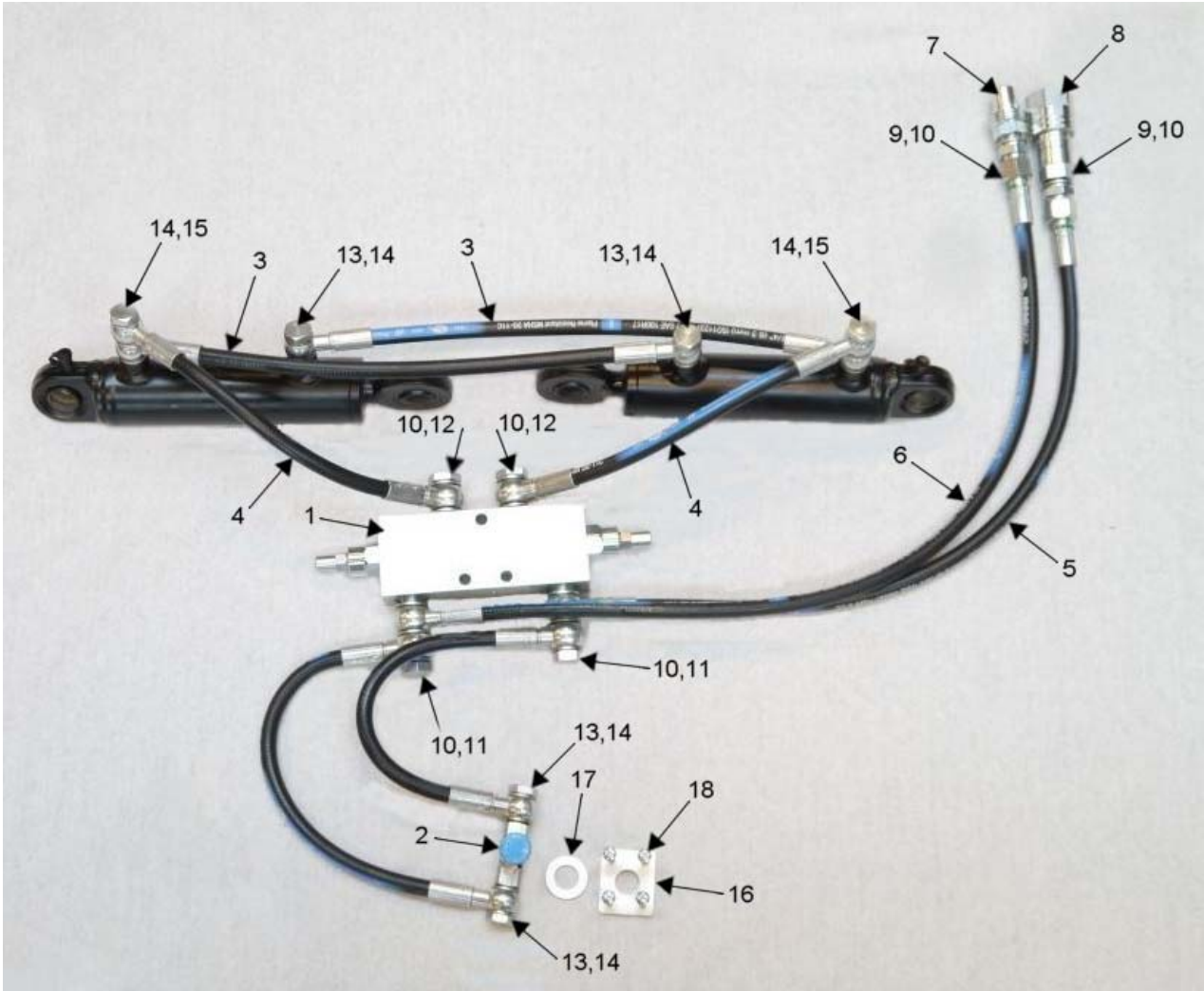

REF.	QTY.	PART No.	DESCRIPTION
		4001706	HYDRAULIC MODULE
1	1	4001042	VALVE
2	1	4001067	FLOW VALVE
3	2	4001045	HOSE
4	2	4001046	HOSE
5	1	4001077	HOSE
6	1	4001078	HOSE
7	1	4001079	QR COUPLING
8	1	4001080	QR COUPLING
9	2	4001081	ADAPTOR
10	12	8650103	BONDED SEAL
11	2	4001043	BANJO BOLT
12	2	4001052	BANJO BOLT
13	4	4001049	BANJO BOLT
14	6	8650102	BONDED SEAL
15	2	4001082	BANJO BOLT (DOUBLE)
16	1	4001083	BRACKET
17	1	4001084	WASHER
18	4	4001085	SCREW

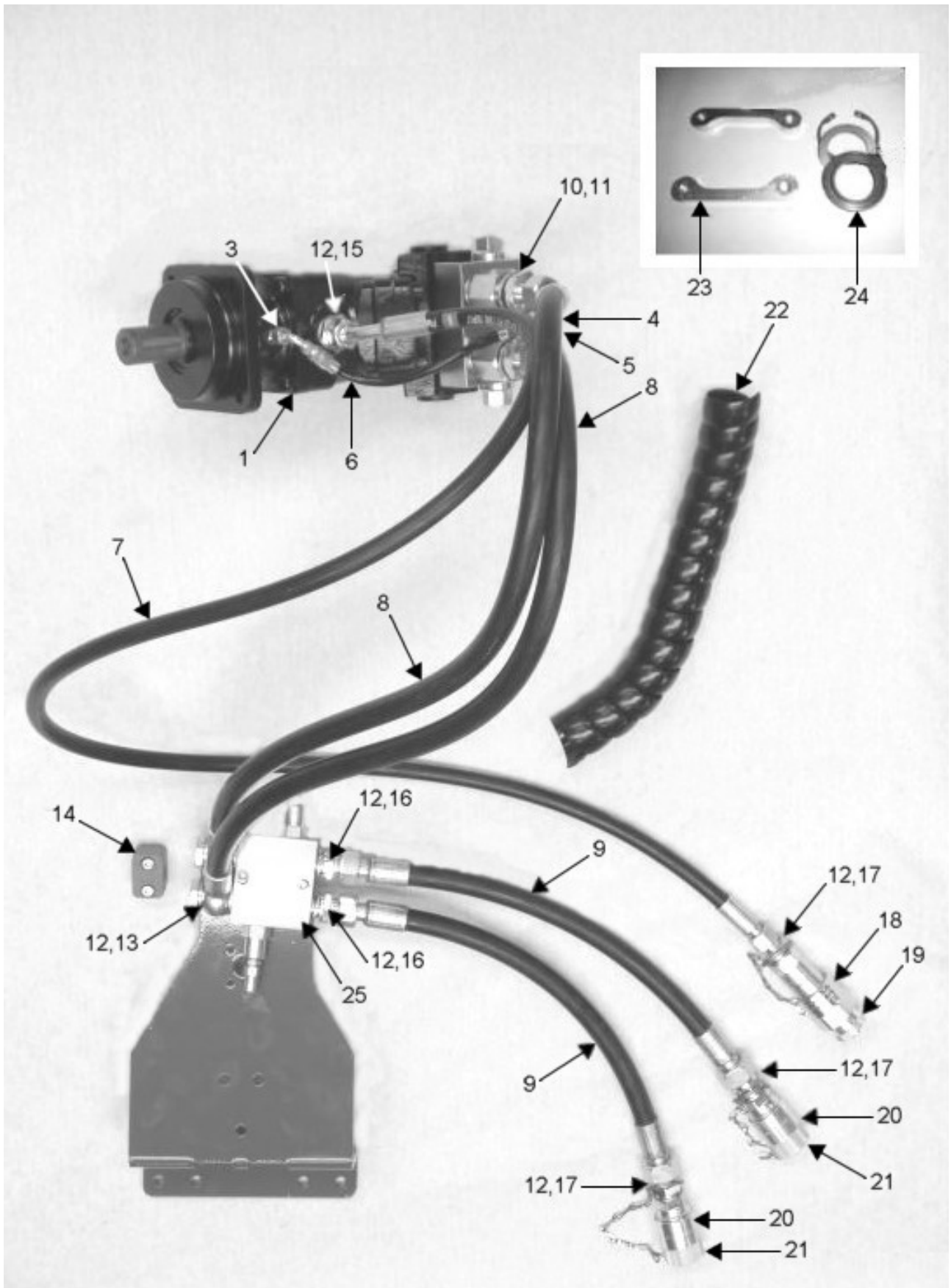

Module(s): 4001705

REF.	QTY.	PART No.	DESCRIPTION
		4001705	MOTOR MODULE
1	1	4001009	HYDRAULIC MOTOR
2	1	4001061	ONE WAY VALVE
3	1	4001062	ADAPTOR
4	1	4001063	ADAPTOR
5	1	4001064	FLUSHING RESTRICTOR
6	1	4001065	HOSE
7	1	4001066	HOSE
8	2	4001067	HOSE
9	2	4001068	HOSE
10	2	8650106	BONDED SEAL
11	2	4001033	ADAPTOR
12	10	8650104	BONDED SEAL
13	2	4001086	BANJO BOLT
14	1	4001038	HOSE CLAMP
15	2	4001034	ADAPTOR
16	2	4001069	ADAPTOR
17	3	4001070	ADAPTOR
18	1	4001071	QR COUPLING
19	1	4001072	DUST CAP
20	2	4001073	QR COUPLING
21	2	4001074	DUST CAP
22	1	4001075	HOSE PROTECTION
23	2	4001010	MOTOR BRACKET
24	1	4001011	MOTOR SHAFT SEAL
25	1	4001087	DOUBLE RELIEF VALVE



REF.	QTY.	PART No.	DESCRIPTION
		4001707	TOOL KIT
1	1	4001017	BAR (BLADE LOCKING TOOL)
2	1	4001018	ALLEN KEY
3	1	4001019	SPANNER



McConnel Limited, Temeside Works, Ludlow, Shropshire SY8 1JL. England.
Telephone: 01584 873131. Facsimile: 01584 876463. www.mcconnel.com