

PM1755

B284 , B324
VERGE MOWERS

PARTS MANUAL

ISSUE 7

IMPORTANT

NOTE HERE THE SERIAL NUMBER OF YOUR MACHINE AND ALWAYS QUOTE IT IN ANY COMMUNICATION WITH US OR YOUR DEALER. THIS IS PARTICULARLY IMPORTANT WHEN ORDERING SPARES. REMEMBER TO INCLUDE ALL NUMBERS AND LETTERS.

MACHINE SERIAL NUMBERS _____

THE INFORMATION GIVEN THROUGHOUT THIS MANUAL IS CORRECT AT THE TIME OF PUBLICATION. HOWEVER, IN THE COURSE OF CONSTANT DEVELOPMENT OF BOMFORD TURNER MACHINES, CHANGES IN SPECIFICATION ARE INEVITABLE. SHOULD YOU FIND THE INFORMATION GIVEN IN THIS BOOK TO BE AT VARIANCE WITH THE MACHINE IN YOUR POSSESSION, YOU ARE ADVISED TO CONTACT THE BOMFORD TURNER SERVICE DEPARTMENT WHERE UP-TO-DATE INFORMATION WILL BE PROVIDED.

THE MANUAL CAN CONTAIN STANDARD AND OPTIONAL FEATURES AND IS NOT TO BE USED AS A MACHINE SPECIFICATION.

THE MACHINE HAS BEEN TESTED AND IS CONSIDERED SAFE IF CAREFULLY USED. ENSURE YOUR OPERATOR IS PROPERLY TRAINED IN ITS USE AND MAINTENANCE.

IMPORTANT

NOTEZ ICI LES NUMEROS DE SERIE DE VOTRE MACHINE ET MENTIONNEZ LES DANS TOUTE COMMUNICATION AVEC NOS SERVICES OU VOTRE REVENDEUR. CECI EST IMPORTANT POUR LA COMMANDE DE PIECES DETACHEES. PENSEZ A NOTER TOUS LES NUMEROS ET TOUTES LES LETTERS.

NUMEROS DE SERIE DE LA MACHINE _____

LES INFORMATIONS DONNEES DANS CE MANUEL SONT CORRECTES CEPENDANT, DU FAIT DE DEVELOPPEMENT CONSTANT DES MACHINES BOMFORD TURNER.

CHANGEMENTS DANS LES CARACTERISTIQUES SONT INEVITABLES.

SI VOUS TROUVEZ QUE LES INFORMATIONS DONNEES NE CORRESPONDENT PAS A VOTRE MACHINE VEUILLEZ CONTACTER LE SERVICE DES REPARATIONS OU DES INFORMATIONS PLUS RECENTES VOUS SERONT DONNEES. CE MANUEL PEUT MONTRER DES CARACTERISTIQUES OPTIONNELLES ET NE PEUT PAS ETRE CONSIDERE COMME SPECIFICATION DE LA MACHINE.

CETTE MACHINE A ETE TESTEE, ET ELLE EST CONSIDEREE COMME FIABLE A CONDITION D'UNE BONNE UTILISATION. ASSUREZ-VOUS QUE VOTRE OPERATEUR EST QUALIFIE EN CE QUI CONCERNE L'UTILISATION DE LA MACHINE AINSI QUE SON ENTRETIEN.

WICHTIG

TRAGEN SIE HIER DIE SERIENNUMMERN IHRER MASCHINE EIN UND GEBEN SIE DIESE IMMER AN, WENN SIE SICH AN UNS ODER IHREN HÄNDLER WENDEN. DAS IST BESONDERS BEI ERSATZTEILBESTELLUNGEN WICHTIG. VERGESSEN SIE NICHT, ALLE ZAHLEN UND BUCHSTABEN ZU NOTIEREN.

SERIENNUMMERN DER MASCHINE _____

DIE ANGABEN IN DIESEM HANDBUCH SIND BEI VERÖFFENTLICHUNG KORREKT. AUFGRUND DER KONSTANTEN WEITERENTWICKLUNG VON BOMFORD TURNER MASCHINEN SIND JEDOCHÄNDERUGDEN IN DER SPEZIFIKATION UNVERMEIDLICH. WENN DIE INFORMATION IN DIESEM HANDBUCH NICHT MIT IHRER MASCHINE ÜBEREINSTIMMEN, NEHMEN SIE BITTE KONTAKT MIT DER BOMFORD TURNER KUNDENDIENSTABTEILUNG AUF, DIE IHNEN GERNE DIE AKTUELLEN INFORMATION ZUKOMMEN LÄSST.

DAS HANDBUCH KANN SOWOHL BESCHREIBUNGEN FÜR DIE STANDARD AUSFÜHRUNG ALS AUCH FÜR ZUBEHÖR ENTHALTEN UND IST NICHT ALS MASCHINENSPEZIFIKATION ZU VERWENDET.

DIE MASCHINE IST GETESTET UND BEI SACHGEMÄSSEM BETRIEB ALS SICHER BEFUNDEN WORDEN. SORGEN SIE DAFÜR, DASS IHR BEDIENPERSONAL IN ANWENDUNG UND WARTUNG RICHTIG GESCHULT WIRD.

B284 AND B324 MACHINES

PAGE AND ILLUSTRATION NUMBERS ARE USED ONLY FOR REFERENCE PURPOSES AND SHOULD NOT BE USED FOR ORDERING SPARE PARTS. PLEASE ENSURE THE CORRECT PART NUMBER AND DESCRIPTION IS GIVEN WHEN ORDERING SPARE PARTS.

*For B284 machines with serial numbers commencing from ..2465H....
For B324 machines with serial numbers commencing from ..1011H....*

B284		B324	
Page No.	Title	Page No.	Title
2 - 1 TO 2 - 2	MAINFRAME LINKS	9 - 1 TO 9 - 2	MAINFRAME LINKS
3 - 1 TO 3 - 2	ARM ASSEMBLY	10-1 TO 10- 2	ARM ASSEMBLY
4 - 1 TO 4 - 3	GEARBOX PTO SHAFT PULLEYS & BELTS	11-1 TO 11- 3	GEARBOX PTO SHAFT PULLEYS & BELTS
5 - 1 TO 5 - 2	RAMS & HOSES	12-1 TO 12- 2	RAMS & HOSES
6 - 1 TO 6 - 2	COWL ASSEMBLY	13-1 TO 13- 2	COWL ASSEMBLY
7 - 1 TO 7 - 2	ROTOR SHAFTS BEARINGS	14-1 TO 14- 2	ROTOR SHAFTS BEARINGS
8 - 1	DECALS	15-1 TO 15 -6	DECALS

OPTIONAL EXTRAS

Page No.	Title
16-1 TO 16-2	ACCUMULATOR
17-1 TO 17-2	VALVE ASSEMBLY OPEN CENTRE
18-1 TO 18-2	VALVE ASSEMBLY LOAD SENSING

IMPORTANT

THIS MACHINE IS FOR VEGETATION CONTROL AND
MUST NOT BE USED FOR ANY OTHER PURPOSE

IT IS POTENTIALLY HAZARDOUS TO FIT OR USE
ANY PARTS OTHER THAN GENUINE BOMFORD TURNER PARTS

THE COMPANY DISCLAIMS ALL LIABILITY FOR THE
CONSEQUENCES OF SUCH USE, WHICH IN ADDITION
VOIDS THE MACHINE WARRANTY

B324

**REAR MOUNTED
SIDESHIFT**

B324

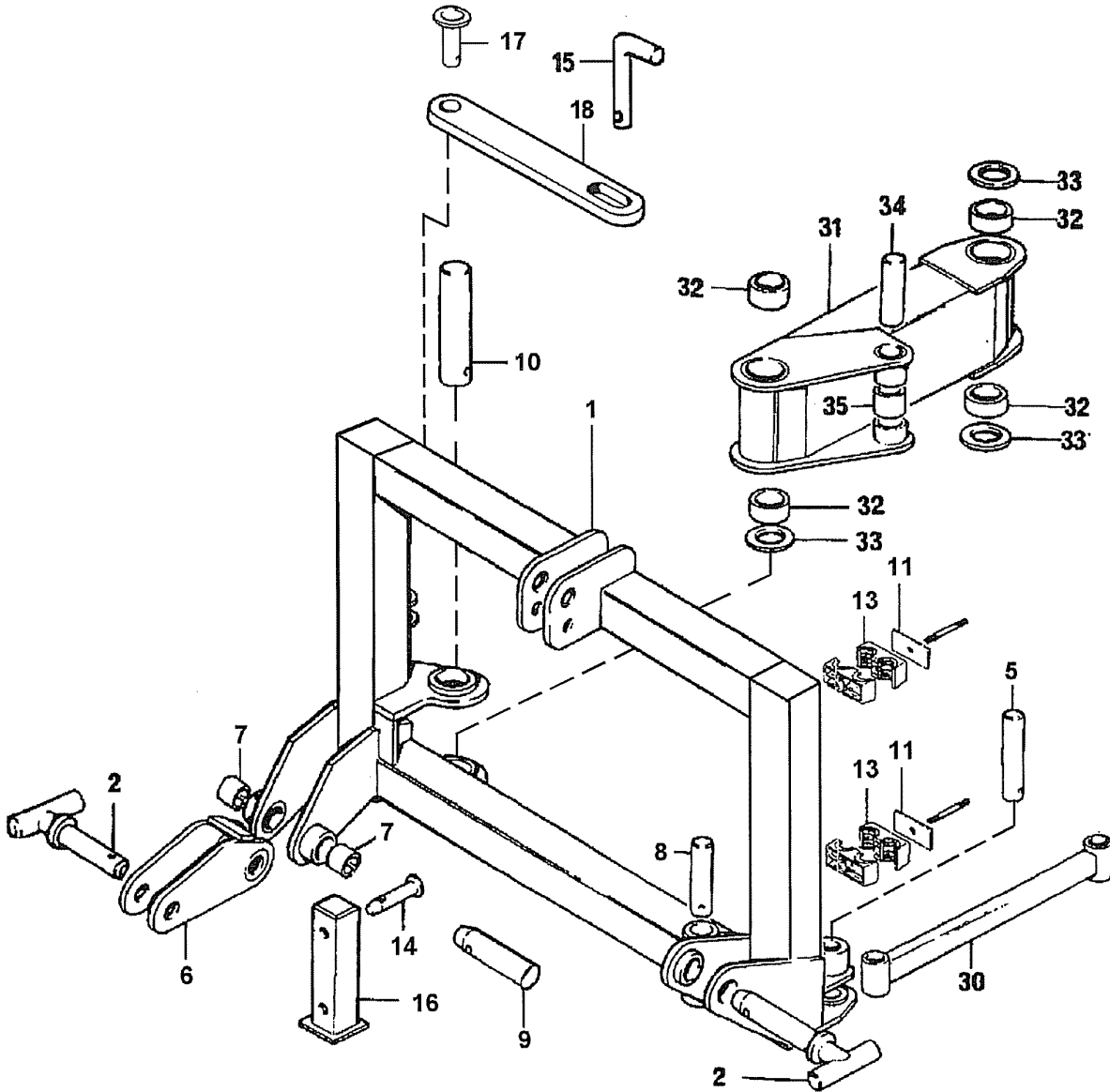

REF	PART NO	DESCRIPTION	QTY
74.781.02/03 MAINFRAME ASSY REAR LH/RH			
*01	09.248.07	MAINFRAME REAR LH	1
01	09.248.06	MAINFRAME REAR RH	1
01	05.227.01	HAMMER DRIVE SCREW NO.6 X 3/8"	2
01	05.774.06	SERIAL NO.PLATE BOMFORD TURNER	1
*02	06.318.01	PIN-1.1/8" DIA X 103	2
02	00.372.01	LINCH PIN	2
02	05.964.01	SPRING COTTER 3.6MM DIA	2
*05	03.654.19	PIN 30 DIA X 153	1
05	05.201.07	TENSION PIN 8MM X 45MM PLATED	1
06	09.241.01	LINK - BREAKOUT	1
07	02.771.06	TENSION BUSH 35 X 30 X 30	2
08	05.291.05	BOLT M8 X 50	1
08	05.287.01	NUT, SELF LOCKING M8	1
08	05.201.07	TENSION PIN 8MM X 45MM PLATED	1
*09	03.654.19	PIN 30 DIA X 153	1
09	05.201.07	TENSION PIN 8MM X 45MM PLATED	1
*10	03.656.62	PIN 40 DIA X 256MM	1
10	05.282.02	SPRING WASHER 10MM PLATED	1
10	05.286.02	NUT M10 PLATED	1
10	05.292.11	BOLT M10 X 80MM PLATED	1
*11	06.418.02	CLAMP PLATE 30 X 6 PLATED	8
11	04.282.30	STUD M8 X 85 PLATED	2
11	05.281.01	FLAT WASHER 8MM PLATED	2
11	05.282.01	SPRING WASHER 8MM PLATED	2
11	05.286.01	NUT M8 PLATED	2
13	06.430.02	CLAMP HOSE 14 X 14	1
*14	03.652.01	PIN 20 DIA X 90	1
14	00.372.01	LINCH PIN	1
*15	03.651.18	PIN 16 DIA X 68MM	1
15	05.953.01	GREASE NIPPLE M6	4
16	09.240.01	STAND	1
*17	03.652.23	PIN 20 DIA X 27	1
17	05.284.14	SPLIT COTTER 5MM X 40MM	1
18	42130.01	STRAP - TRANSPORT	1
72.482.01 SWING LINKS			
30	09.237.01	LINK - SWING	1
31	09.234.01	LINK - SWING RAM	1
32	08.297.02	BUSH - PLASTIC 47 X 40 X 40	4
33	09.232.01	THRUST WASHER	3
*34	03.653.56	PIN 25 DIA X 178MM	1
34	05.201.07	TENSION PIN 8MM X 45MM PLATED	1
34	05.953.01	GREASE NIPPLE M6	1
35	09.235.01	SPACER - 40 X 25.5 - 36	1

*MAIN PART IN GROUP, RELATED PARTS HAVE SAME REFERENCE NUMBER

B324

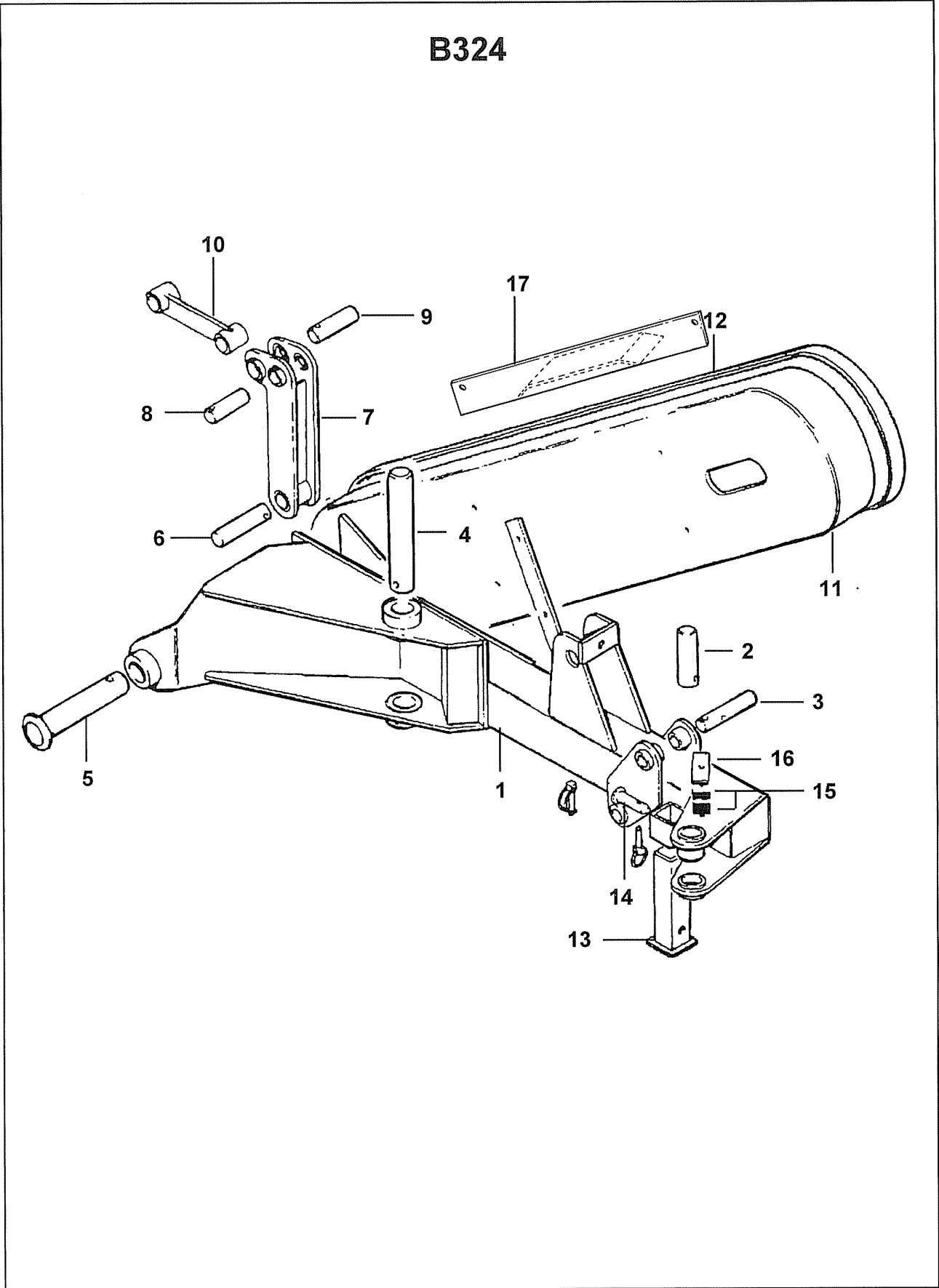

REF	PART NO	DESCRIPTION	QTY
72.551.01, 72.485.01 ARM ASSEMBLY LH/RH			
*01	09.300.02	ARM LH (RH-FM)	1
01	09.300.01	ARM RH	1
01	05.201.11	TENSION PIN 5MM X 45MM PLATED	2
*02	03.654.73	PIN 30 DIA X 140MM	1
02	05.953.01	GREASE NIPPLE M6	1
*03	03.653.25	PIN 25 DIA X 135	1
03	05.201.07	TENSION PIN 8MM X 45MM PLATED	1
03	05.282.01	SPRING WASHER 8MM PLATED	1
03	05.286.01	NUT M8 PLATED	1
03	05.291.06	BOLT M8 X 55MM PLATED	1
03	05.953.01	GREASE NIPPLE M6	1
*04	03.656.63	PIN 40 DIA X 283MM	1
04	05.282.02	SPRING WASHER 10MM PLATED	1
04	05.286.02	NUT M10 PLATED	1
04	05.292.11	BOLT M10 X 80MM PLATED	1
04	05.953.03	GREASE NIPPLE M10	1
*05	03.656.61	PIN 40 DIA X 250MM	1
05	05.282.02	SPRING WASHER 10MM PLATED	1
05	05.286.02	NUT M10 PLATED	1
05	05.292.11	BOLT M10 X 80MM PLATED	1
05	05.953.01	GREASE NIPPLE M6	1
*06	03.654.08	PIN 30 DIA X 140MM	1
06	05.201.07	TENSION PIN 8MM X 45MM PLATED	1
*07	09.233.01	LINK - COWL RAM	1
07	05.953.01	GREASE NIPPLE M6	1
*08	03.653.55	PIN 25 DIA X 98MM	1
08	05.201.07	TENSION PIN 8MM X 45MM PLATED	1
*09	03.654.53	PIN 30 DIA X 92MM	1
09	05.201.07	TENSION PIN 8MM X 45MM PLATED	1
*10	09.231.01	LINK - COWL	1
10	05.953.01	GREASE NIPPLE M6	2
*11	41764.01	GUARD - REAR LH	1
11	41764.02	GUARD - REAR RH	1
11	05.264.12	SETSCREW M10 X 25MM PLATED	2
11	05.264.13	SETSCREW M10 X 30MM PLATED	2
11	05.282.02	SPRING WASHER 10MM PLATED	4
*12	41775.01	GUARD - COVER	1
12	05.264.11	SETSCREW M10 X 20MM PLATED	4
12	05.282.02	SPRING WASHER 10MM PLATED	4
13	09.240.01	STAND	1
*14	03.652.01	PIN 20 DIA X 90	1
14	00.372.01	LINCH PIN	1
*15	06.430.02	CLAMP HOSE 14 X 14	2
15	04.282.32	STUD M8 X 52	1
15	05.281.01	FLAT WASHER 8MM PLATED	1
15	05.282.01	SPRING WASHER 8MM PLATED	1
15	05.286.01	NUT M8 PLATED	1
16	06.418.02	CLAMP PLATE 30 X 6 PLATED	1
17	43008.01	BRACKET-BELT SUPPORT	1

*MAIN PART IN GROUP, RELATED PARTS HAVE SAME REFERENCE NUMBER

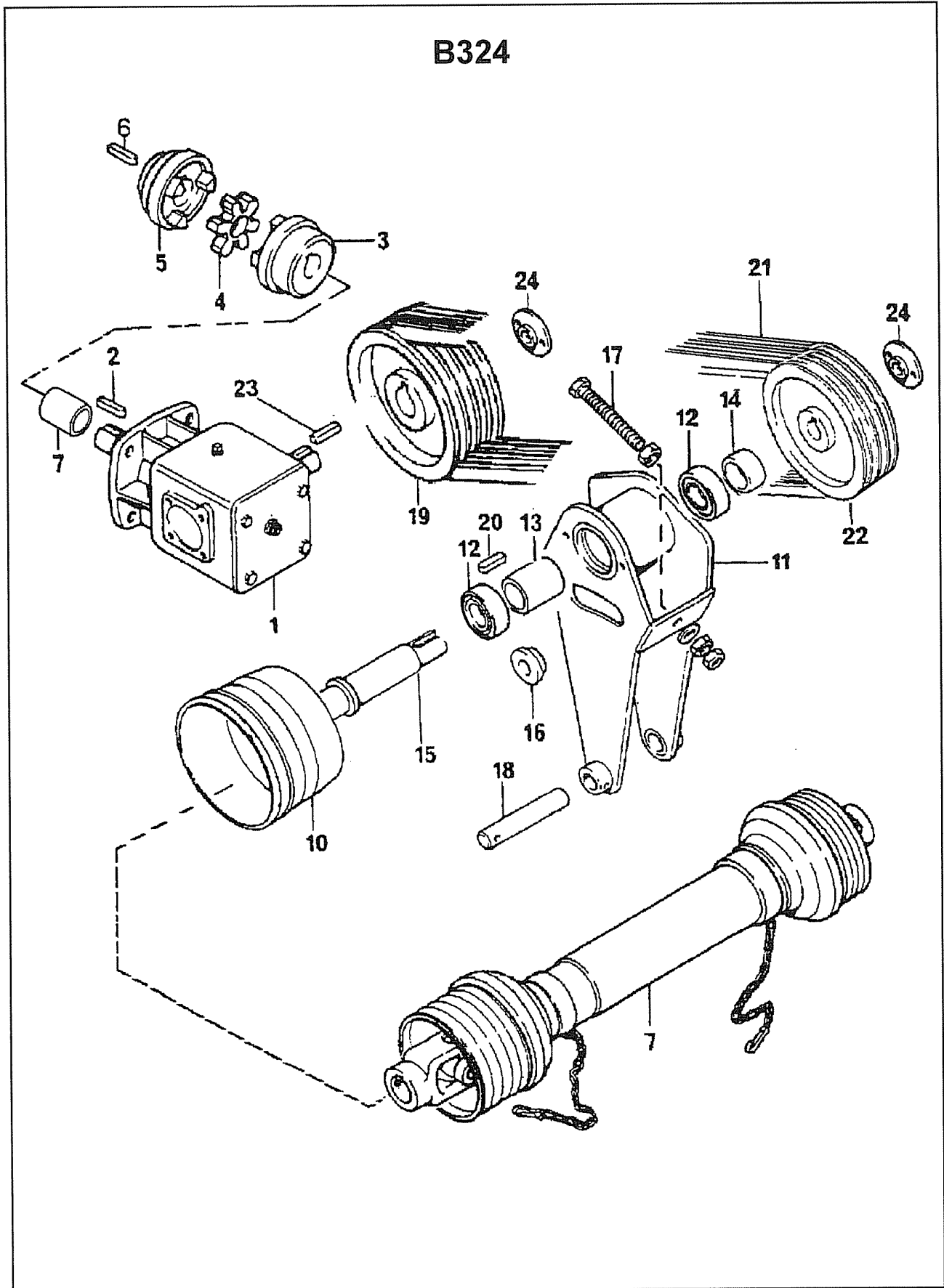

REF	PART NO	DESCRIPTION	QTY
72.552.01, 72.483.01 DRIVE BRACKET,PULLEYS & BELTS LH/RH			
*10	09.236.01	GUARD - PLASTIC PTO	1
10	05.264.11	SETSCREW M10 X 20MM PLATED	2
10	05.281.02	FLT WASHER 10MM PLATED FORM C	2
10	05.282.02	SPRING WASHER 10MM PLATED	2
*11	41768.03	BRACKET - DRIVE RH FRONT	1
11	41768.01	BRACKET - DRIVE LH FRONT	1
12	03.007.06	BEARING - BALL 40MM BORE	2
13	09.259.01	SPACER 50 O/D X 40.2 I/D	1
14	09.264.01	SPACER 50 O/D X 40.2 I/D - 26	1
*15	41730.01	SHAFT - PULLEY/PTO	1
15	05.264.02	SETSCREW M8 X 25MM PLATED	2
15	05.264.24	SETSCREW M12 X 35MM PLATED	1
15	05.282.01	SPRING WASHER 8MM PLATED	2
15	05.282.03	SPRING WASHER 12MM PLATED	1
15	09.297.01	WASHER 75 O/D X 13 I/D X 6	1
15	41731.01	SPACER 50 X 40.2 - 10	1
*16	09.263.01	COLLAR - CLAMP	1
16	05.264.34	SETSCREW M16 X 35MM PLATED	1
16	05.282.04	SPRING WASHER 16MM PLATED	1
*17	41769.01	BOLT - ADJUSTMENT	1
17	05.281.04	FLAT WASHER 16MM PLATED	4
17	05.286.04	NUT M16 PLATED	3
*18	03.653.57	PIN 25 DIA X 170MM	1
18	05.201.07	TENSION PIN 8MM X 45MM PLATED	1
*19	41.245.01	PULLEY - 250 PCD X 4 SPB	1
19	05.388.01	SOCKET GRUBSCREW M8 X 25MM CONE PT	1
20	05.960.03	KEY-SEP 10MM X 8MM X 50MM	1
21	05.299.51	BELT XPB 2500 QUAD POWER GATES	4
*22	41.244.01	PULLEY - 180 X 4 SPB	1
22	05.388.01	SCKT GRUBSCREW M8 X 25MM CONE PT	1
23	05.960.22	KEY-REP 10 X 8 X 58	1
*24	09.297.01	WASHER 75 O/D X 13 I/D X 6	1
24	05.264.02	SETSCREW M8 X 25MM PLATED	2
24	05.264.23	SETSCREW M12 X 30MM PLATED	1
24	05.282.01	SPRING WASHER 8MM PLATED	2
24	05.282.03	SPRING WASHER 12MM PLATED	1

***MAIN PART IN GROUP, RELATED PARTS HAVE SAME REFERENCE NUMBER**

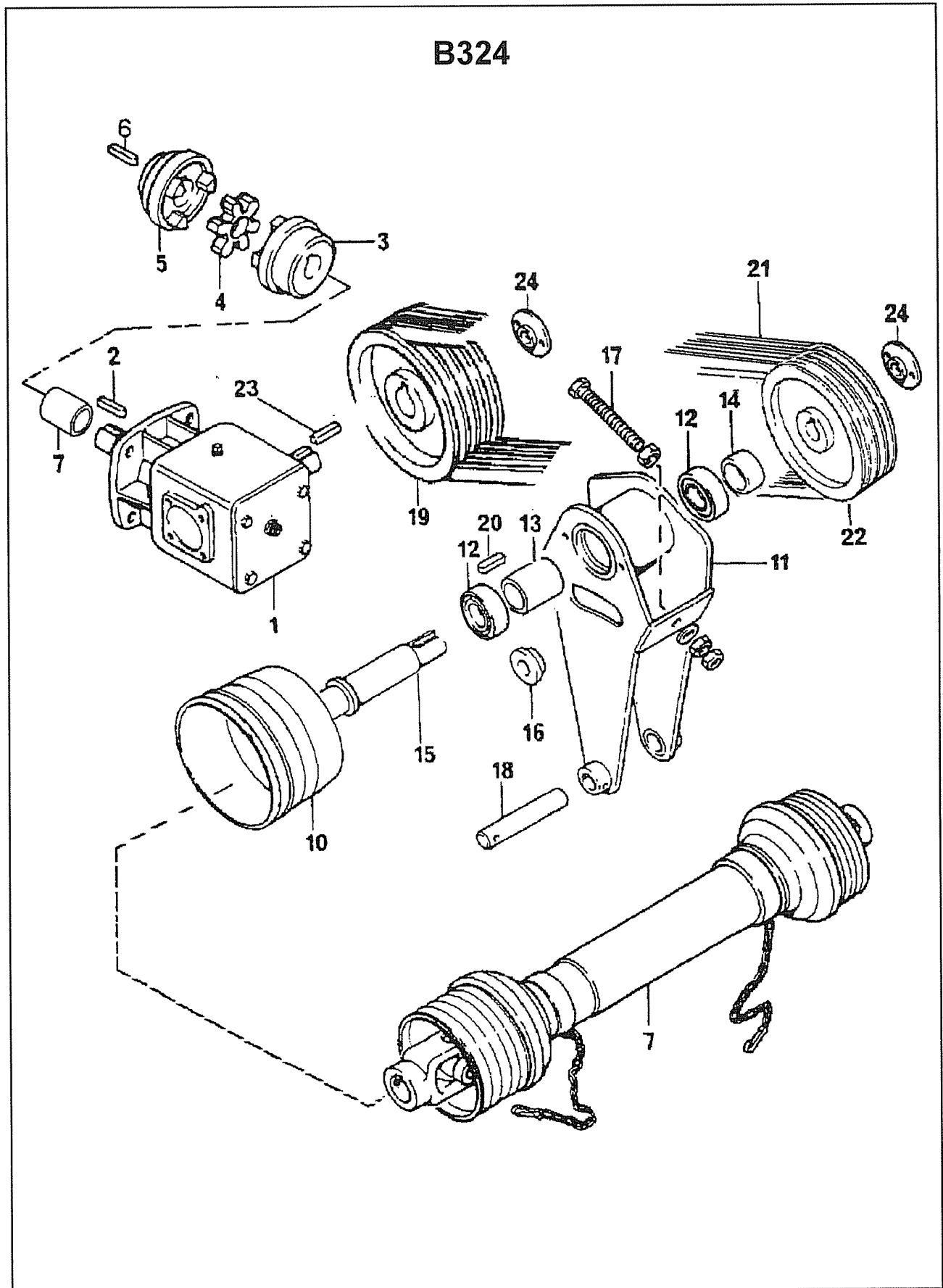

REF	PART NO	DESCRIPTION	QTY
72.484.01, 72.555.01 GEARBOX ASSEMBLY LH/RH			
*01	09.250.04	GEARBOX ASSEMBLY COMER RH	1
01	02.824.01	WASHER 50 O/D X 13 I/D X 6MM	1
01	05.264.24	SETSCREW M12 X 35MM PLATED	1
01	05.282.03	SPRING WASHER 12MM PLATED	1
02	05.960.22	KEY-REP 10 X 8 X 58	1
*03	07.078.05	HUB - COUPLING (KEYED)	1
03	05.388.01	SOCKET GRUBSCREW M8 X 25MM CONE PT	4
04	07.078.04	DRIVE - COUPLING	1
05	07.078.03	HUB - COUPLING (KEYED)	1
06	05.960.16	KEY-S/REP 12MM X 8MM X 40MM	1
07	42613.01	SPACER 50 X 35.5 - 33MM	1
72.478.01 PTO SHAFT ASSEMBLY			
*08	41624.06	PTO SHAFT ASSY 810MM C/C)	1
08	41624.31	CROSS JOURNAL SET)	-
08	41624.34	COMPLETE SHIELD)	-
76.536.01 PTO SHAFT ASSEMBLY			
*08	42788.01	PTO SHAFT ASSY 810MM C/C)	1
08	06.154.13	CROSS JOURNAL SET)	-
08	04.402.31	COMPLETE SHIELD)	-

**Check
type
for
replacement
parts**

***MAIN PART IN GROUP, RELATED PARTS HAVE SAME REFERENCE NUMBER**

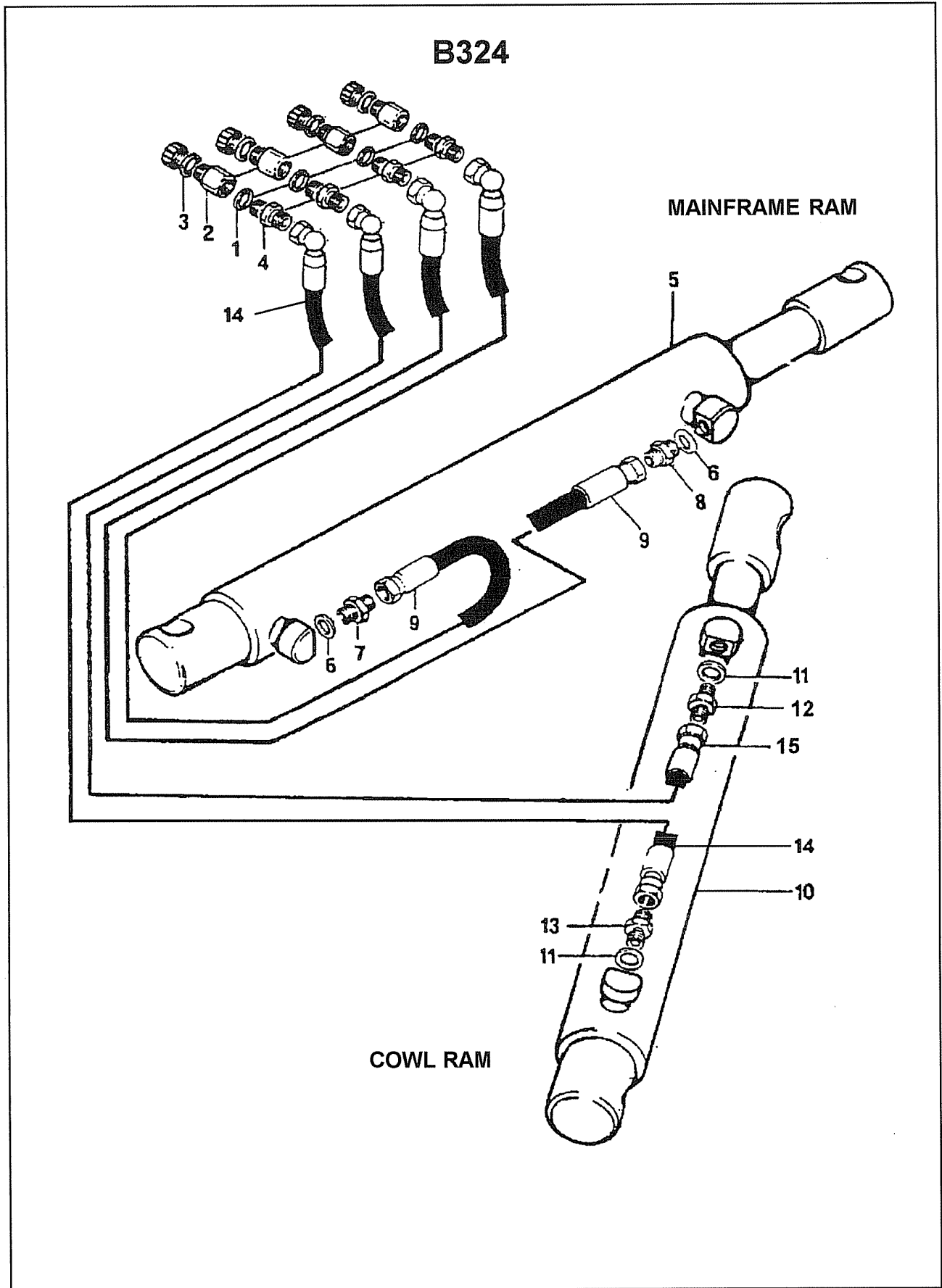

REF	PART NO	DESCRIPTION	QTY
72.477.01 RAMS/HOSES			
01	05.290.05	BONDED SEAL 1/2"BSP	4
*02	05.225.01	ADAPTOR-RDCG.1/2"BSP X 3/8"BSP	4
02	05.300.03	PLUG-PLASTIC 1/2"BSP FEMALE	4
03	05.290.04	BONDED SEAL 3/8"BSP	4
04	01.099.01	ADAPTOR 3/8"BSP X 1/4BSP	4
*05	41.042.03	RAM ASSY - 50 BORE	1
05	41.042.01	SEAL KIT - 41.042.XX RAMS.	-
06	05.290.04	BONDED SEAL 3/8"BSP	2
07	03.028.12	RESTRICTOR 3/8"BSP X1/4"BSP 1.70	1
08	03.028.12	RESTRICTOR 3/8" X 1/4"BSP 1.27	1
09	10.002.34	HOSE 1/4"BSP ST X 90 S.SEAL 2400	2
*10	09.982.10	RAM ASSY-D/A 60 BORE X 430 STK	1
10	09.982.01	SEAL KIT FOR 09.982.XX RAMS	-
11	05.290.04	BONDED SEAL 3/8"BSP	2
12	03.028.16	RESTRICTOR 3/8"BSP X 1/4"BSP 1.00MM	1
13	03.028.12	RESTRICTOR 3/8" X 1/4"BSP 1.70MM	1
14	10.002.44	HOSE 1/4"BSP ST X 90 S.SEAL 3400	1
15	10.002.39	HOSE 1/4"BSP ST X 90 S.SEAL 2900	1

***MAIN PART IN GROUP, RELATED PARTS HAVE SAME REFERENCE NUMBER**

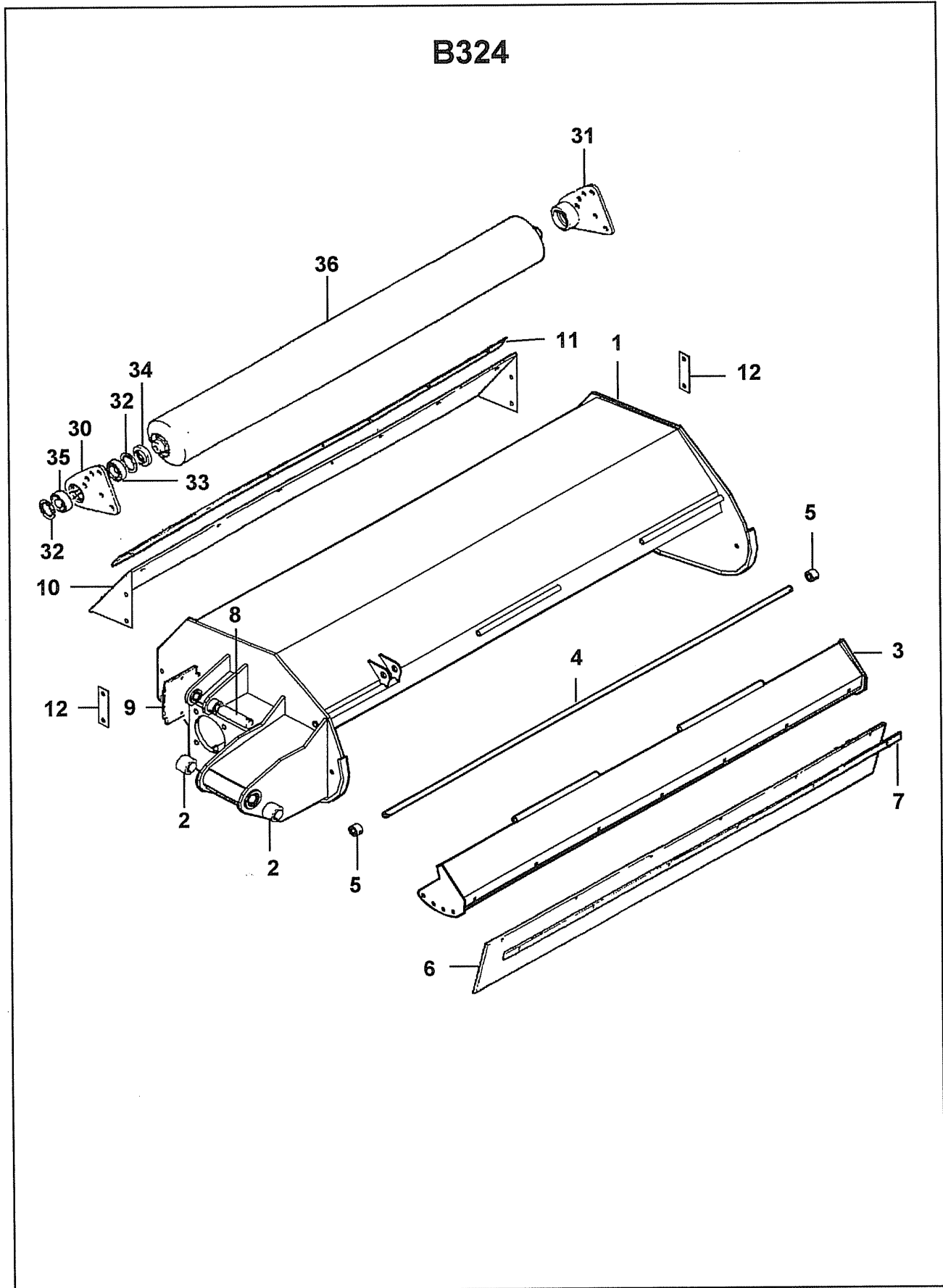

REF	PART NO	DESCRIPTION	QTY
74.753.05/03 COWL ASSY 1600 REAR LH/RH			
*01	42323.03	COWL - REAR LH 1600	1
01	42323.01	COWL - REAR RH 1600	1
01	03.886.01	STUD M16 X 60MM PLATED	4
01	05.281.04	FLAT WASHER 16MM PLATED	4
01	05.282.03	SPRING WASHER 12MM PLATED	6
01	05.282.04	SPRING WASHER 16MM PLATED	4
01	05.286.03	NUT M12 PLATED	6
01	05.286.04	NUT M16 PLATED	4
01	05.839.34	BOLT CUP SQ M12 X 35 (PLATED)	5
01	05.839.36	BOLT CUP SQ M12 X 50 (PLATED)	1
02	08.297.02	BUSH - PLASTIC 47 X 40 X 40	2
*03	42125.02	GUARD - FRONT ADJUSTABLE 1600	1
03	05.282.03	SPRING WASHER 12MM PLATED	2
03	05.286.03	NUT M12 PLATED	2
03	05.839.26	BOLT CUP SQ M12 X 30 (PLATED)	2
*04	42129.04	PIN - PIVOT FRONT GUARD 1600	1
04	05.201.17	TENSION PIN 3MM X 25MM PLATED	2
05	41436.02	SPACER-PIVOT FRONT GUARD	2
*06	42126.03	GUARD - FLEXIBLE FRONT 1600	1
*07	10.120.01	BACKING STRIP	1
07	9293054	BOLT CUP SQUARE M8X25 (PLATE)	7
07	05.282.01	SPRING WASHER 8MM PLATED	7
07	05.286.01	NUT M8 PLATED	7
*08	03.654.54	PIN 30 DIA X 121MM	1
08	05.282.01	SPRING WASHER 8MM PLATED	1
08	05.286.01	NUT M8 PLATED	1
08	05.291.06	BOLT M8 X 55MM PLATED	1
*09	09.249.01	COVER - COWL DRIVE	1
09	05.282.01	SPRING WASHER 8MM PLATED	2
09	30.068.95	SCREW M8 X 12 8.8 GRADE Z/P	2
10	42127.02	GUARD - FLEXIBLE REAR 1600	1
*11	10.120.01	BACKING STRIP	1
11	05.282.01	SPRING WASHER 8MM PLATED	7
11	05.286.01	NUT M8 PLATED	7
11	9293054	BOLT CUP SQUARE M8 X 25 (PLATE)	7
*12	41883.01	CLAMP - GUARD	2
12	05.282.03	SPRING WASHER 12MM PLATED	4
12	05.286.03	NUT M12 PLATED	4
12	05.839.26	BOLT CUP SQ M12 X 30 (PLATED)	4
74.750.02 ROLLER ASSY 150 DIA			
30	41897.01	BRACKET - ROLLER 150 LH	1
31	41897.02	BRACKET - ROLLER 150 RH	1
32	05.959.05	CIRCLIP - INT 62MM DIA	4
33	42954.01	BEARING - D/ROW BALL 30MM BORE	2
34	04.164.04	SEAL-LIP 40DIA X 10MM	2
*35	41851.01	CAP - BEARING RETAINER	2
35	05.953.01	GREASE NIPPLE M6	4
*36	42955.08	ROLLER	1
36	05.234.01	WASHER 44.5 X 13 X 5MM PLATED	2
36	05.282.03	SPRING WASHER 12MM PLATED	2
36	05.625.10	SOCKET CAPSCREW M12 X 30 DOME HD PLT	2

*MAIN PART IN GROUP, RELATED PARTS HAVE SAME REFERENCE NUMBER

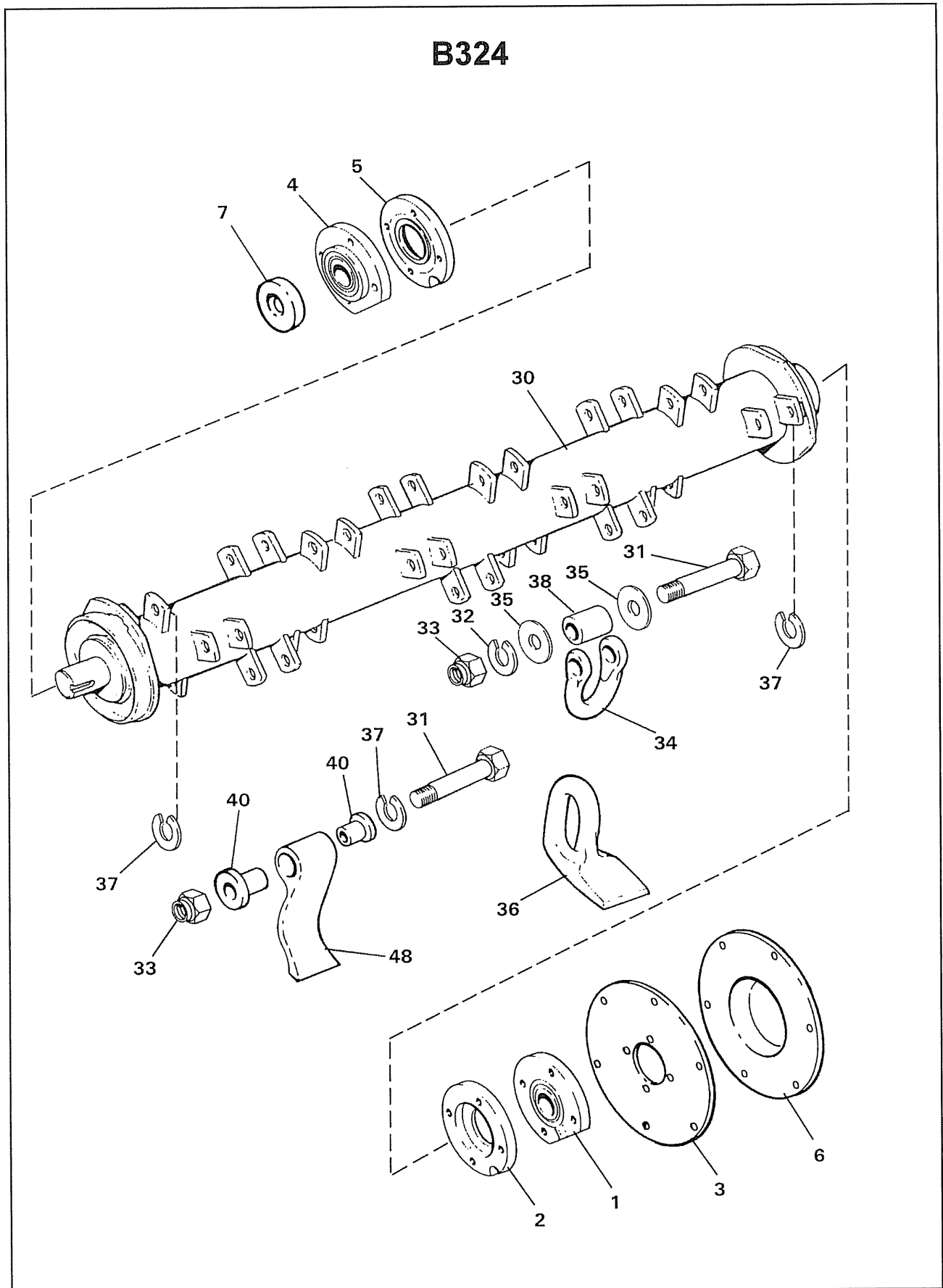

REF	PART NO	DESCRIPTION	QTY
72.474.02 BEARING ASSEMBLY			
*01	06.221.01	BEARING ASSEMBLY 40 - BORE	1
01	05.264.25	SETSCREW M12 X 40MM PLATED	4
01	05.282.03	SPRING WASHER 12MM PLATED	4
*02	06.219.01	DISC-SHIELD	1
02	05.345.05	SOCKET CSK SCREW M12 X 1.75 X 40	1
*03	41.238.02	PLATE - BEARING	1
03	05.264.22	SETSCREW M12 X 25MM PLATED	1
03	05.264.24	SETSCREW M12 X 35MM PLATED	4
03	05.282.03	SPRING WASHER 12MM PLATED	6
03	05.286.03	NUT M12 PLATED	6
*04	06.221.01	BEARING ASSEMBLY 40 - BORE	1
04	05.264.25	SETSCREW M12 X 40MM PLATED	4
04	05.282.03	SPRING WASHER 12MM PLATED	4
*05	06.219.01	DISC-SHIELD	1
05	02.824.01	WASHER 50 O/DX13 I/D X 6MM	1
05	05.264.23	SETSCREW M12 X 30MM PLATED	1
05	05.283.03	SHAKEPROOF WASHER 12MM PLATED	1
06	42324.01	GUARD - NON DRIVE	1
07	07.165.01	PLATE - RETAINING	1
74.751.09 ROTOR SHAFT ASSY 1600			
30	41778.05	ROTOR SHAFT ASSEMBLY 4224901/0295901AC	1
31	05.775.10	BOLT - SPECIAL M14 X 94MM	44
32	05.282.08	SPRING WASHER 14MM PLATED	44
33	05.968.06	S.LOCKING NUT M14 (FINE) PLATE	44
34	05.895.01	SHACKLE-FORGED	44
35	05.281.04	FLAT WASHER 16MM PLATED	88
36	02.959.01	FLAIL - FORGED	44
37	05.282.04	SPRING WASHER 16MM PLATED	2
38	02.807.01	SPACER 1"O/D X 16MM I/D X 27MM	44
74.751.10 ROTOR SHAFT ASSY 1600			
30	41778.06	ROTOR SHAFT ASSEMBLY 4224901/4215501AC	1
31	05.775.10	BOLT - SPECIAL M14 X 94MM	44
32	05.282.08	SPRING WASHER 14MM PLATED	44
33	05.968.06	S.LOCKING NUT M14 (FINE) PLATE	44
37	05.282.04	SPRING WASHER 16MM PLATED	2
40	09.894.01	COLLAR - PIVOT	88
48	42155.01	FLAIL-SINGLE EDGE (PRO-FLAIL)	44

*MAIN PART IN GROUP, RELATED PARTS HAVE SAME REFERENCE NUMBER

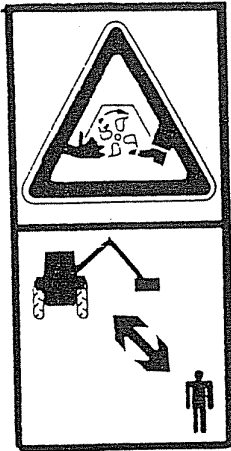

09.821.05

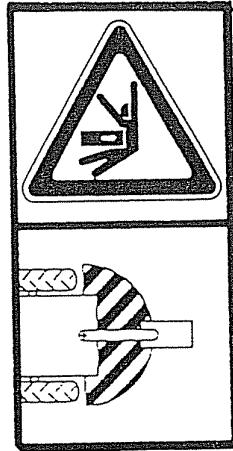

09.821.06

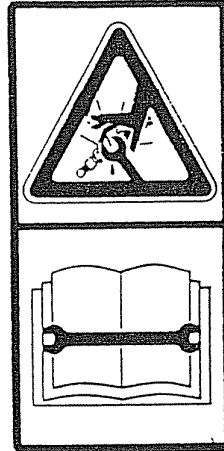

09.821.07

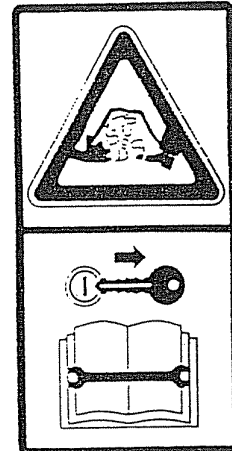

09.821.08

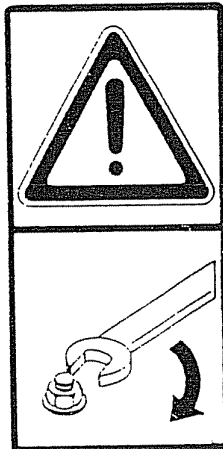

09.821.10

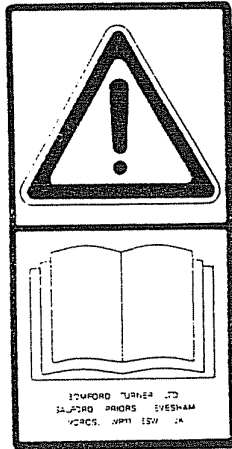

09.821.01

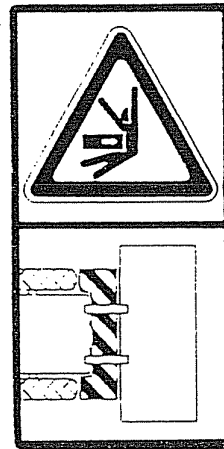

09.821.16



09.821.17

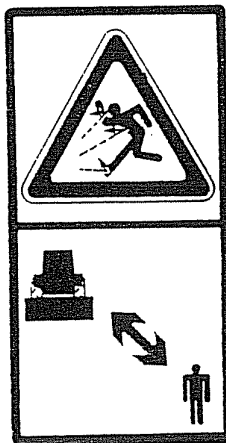

09.821.18



09.821.20

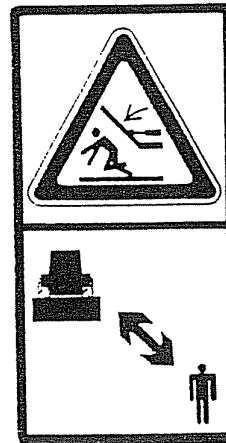

09.821.21

REF	PART NO	DESCRIPTION	QTY
76.023.03 DECALS			
01	09.837.01	DECAL - BOMFORD	2
04	09.843.04	DECAL - LIFT POINT 750 KG	1
05	09.821.21	DECAL - FALLING WING	1
06	09.821.20	DECAL - SHAFT ENTANGLEMENT	1
07	09.821.18	DECAL - THROWN DEBRIS	1
08	09.821.17	DECAL - UNSUPPORTED MACHINE	1
09	09.821.16	DECAL - KEEP OUT ZONE	1
10	09.821.01	DECAL - READ INSTRUCTION BOOK	1
11	09.821.10	DECAL - KEEP NUTS TIGHT	1
12	09.821.08	DECAL - SAFEWORKING ON HEAD	1
13	09.821.07	DECAL - RESIDUAL PRESSURE	1
14	09.821.06	DECAL - SLEW DANGER	1
15	09.821.05	DECAL - CUTTING HEAD DANGER	1
16	09.811.05	DECAL - MAX PTO SPEED 1000	1
17	09.810.02	DECAL-GREASE (40 HOURS)	4
18	09.810.01	DECAL-GREASE (8 HOURS)	9
19	09.852.01	DECAL - ARM FLOAT	-
20	09.980.30	DECAL - B324	2

REF	PART NO	DESCRIPTION	QTY
76.023.03 DECALS			
01	09.837.01	DECAL - BOMFORD	2
04	09.843.04	DECAL - LIFT POINT 750 KG	1
05	09.821.21	DECAL - FALLING WING	1
06	09.821.20	DECAL - SHAFT ENTANGLEMENT	1
07	09.821.18	DECAL - THROWN DEBRIS	1
08	09.821.17	DECAL - UNSUPPORTED MACHINE	1
09	09.821.16	DECAL - KEEP OUT ZONE	1
10	09.821.01	DECAL - READ INSTRUCTION BOOK	1
11	09.821.10	DECAL - KEEP NUTS TIGHT	1
12	09.821.08	DECAL - SAFEWORKING ON HEAD	1
13	09.821.07	DECAL - RESIDUAL PRESSURE	1
14	09.821.06	DECAL - SLEW DANGER	1
15	09.821.05	DECAL - CUTTING HEAD DANGER	1
16	09.811.05	DECAL - MAX PTO SPEED 1000	1
17	09.810.02	DECAL - GREASE (40 HOURS)	4
18	09.810.01	DECAL - GREASE (8 HOURS)	9
19	09.852.01	DECAL - ARM FLOAT	-
20	09.980.30	DECAL - B324	2

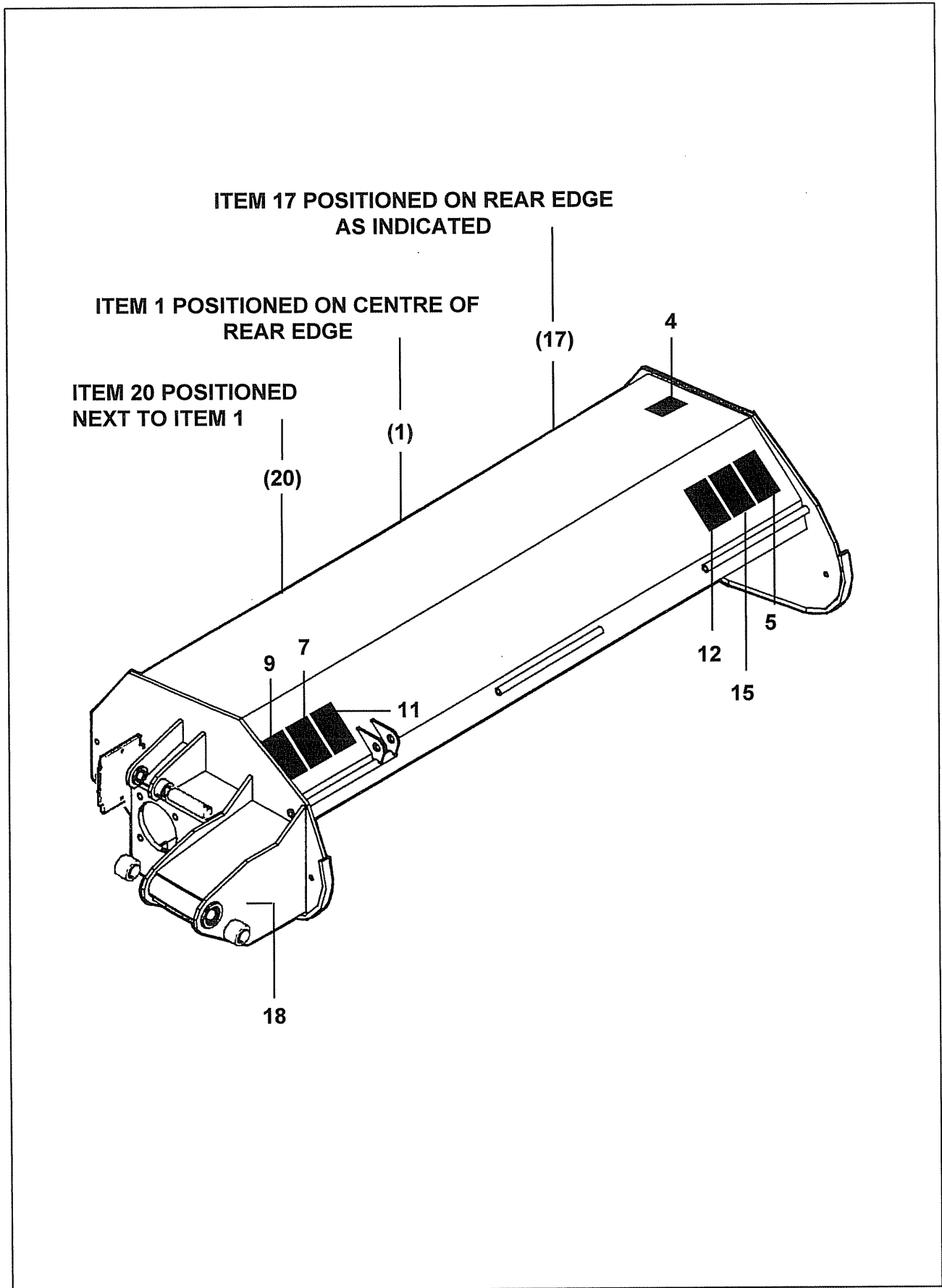

REF	PART NO	DESCRIPTION	QTY
76.023.03 DECALS			
01	09.837.01	DECAL - BOMFORD	2
04	09.843.04	DECAL - LIFT POINT 750 KG	1
05	09.821.21	DECAL - FALLING WING	1
06	09.821.20	DECAL - SHAFT ENTANGLEMENT	1
07	09.821.18	DECAL - THROWN DEBRIS	1
08	09.821.17	DECAL - UNSUPPORTED MACHINE	1
09	09.821.16	DECAL - KEEP OUT ZONE	1
10	09.821.01	DECAL - READ INSTRUCTION BOOK	1
11	09.821.10	DECAL - KEEP NUTS TIGHT	1
12	09.821.08	DECAL - SAFEWORKING ON HEAD	1
13	09.821.07	DECAL - RESIDUAL PRESSURE	1
14	09.821.06	DECAL - SLEW DANGER	1
15	09.821.05	DECAL - CUTTING HEAD DANGER	1
16	09.811.05	DECAL - MAX PTO SPEED 1000	1
17	09.810.02	DECAL - GREASE (40 HOURS)	4
18	09.810.01	DECAL - GREASE (8 HOURS)	9
19	09.852.01	DECAL - ARM FLOAT	-
20	09.980.30	DECAL - B324	2

**OPTIONAL
EXTRAS**

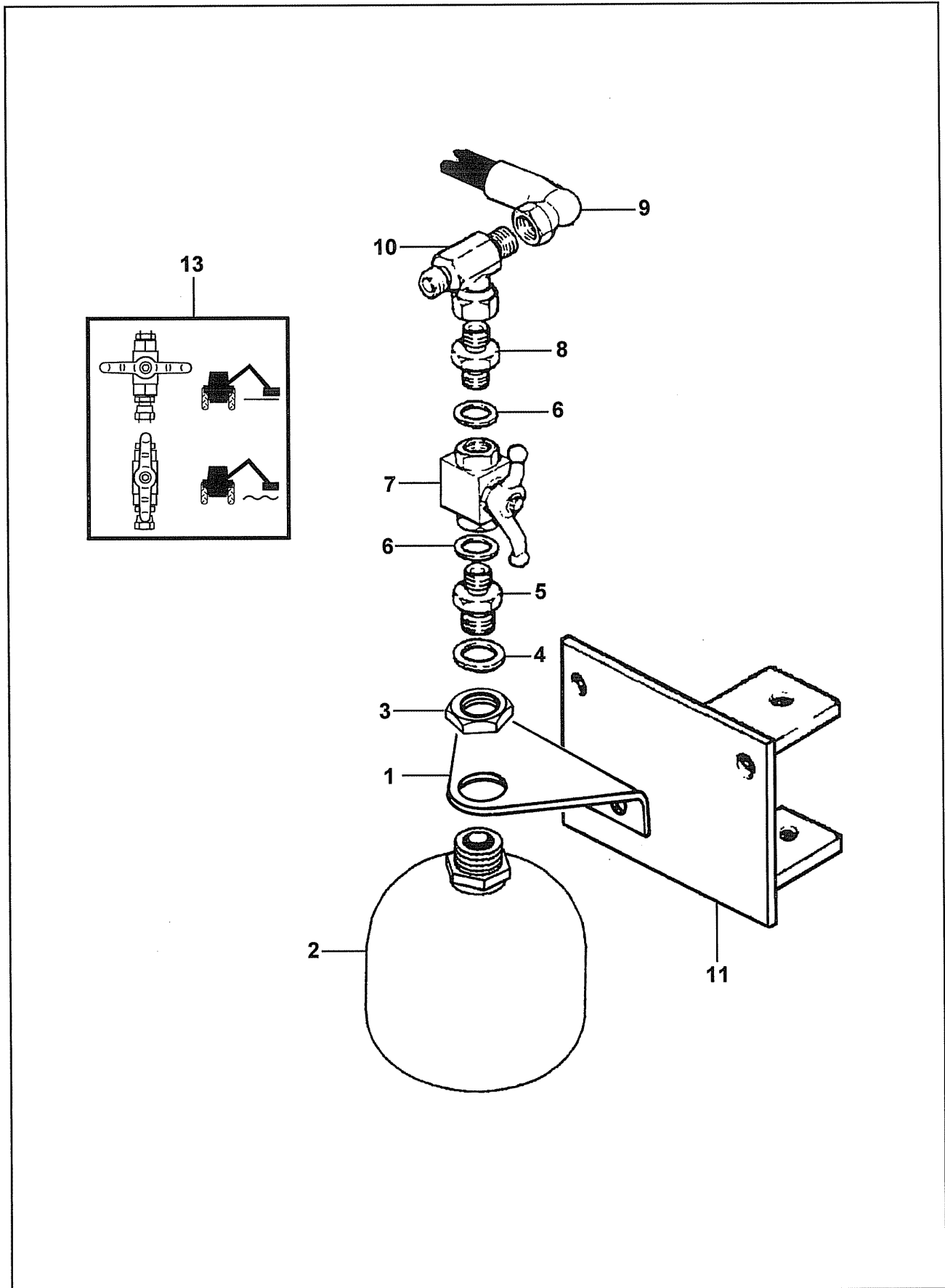

REF	PART NO	DESCRIPTION	QTY
72.657.01 B313S ACCUMULATOR KIT			
*01	43239.01	BRACKET	1
01	05.264.13	SETSCREW M10 X 30MM PLATED	2
01	05.282.02	SPRING WASHER 10MM PLATED	2
01	05.286.02	NUT M10 PLATED	2
02	41451.02	ACCUMULATOR	1
03	8126035	M33 NUT, BULKHEAD	1
04	05.290.05	BONDED SEAL 1/2"BSP	1
05	05.123.01	ADAPTOR 1/2" BSP X 3/8" BSP	1
06	05.290.04	BONDED SEAL 3/8"BSP	2
07	08.200.01	VALVE - ISOLATING 3/8" BSP	1
08	01.099.01	ADAPTOR 3/8BSP X 1/4BSP	1
09	10.002.22	HOSE 1/4"BSP ST X 90 S.SEAL 1200	1
10	04.056.10	ADAPTOR - TEE 1/4"BSP F/M/M	1
*11	42815.01	BRACKET - ACCUMUATOR	1
11	05.282.02	SPRING WASHER 10MM PLATED	1
11	05.286.02	NUT M10 PLATED	1
11	05.292.15	BOLT M10 X 120MM PLATED	1
12	42815.02	SPACER	-
13	09.852.01	DECAL - ARM FLOAT	1

*MAIN PART IN GROUP, RELATED PARTS HAVE SAME REFERENCE NUMBER

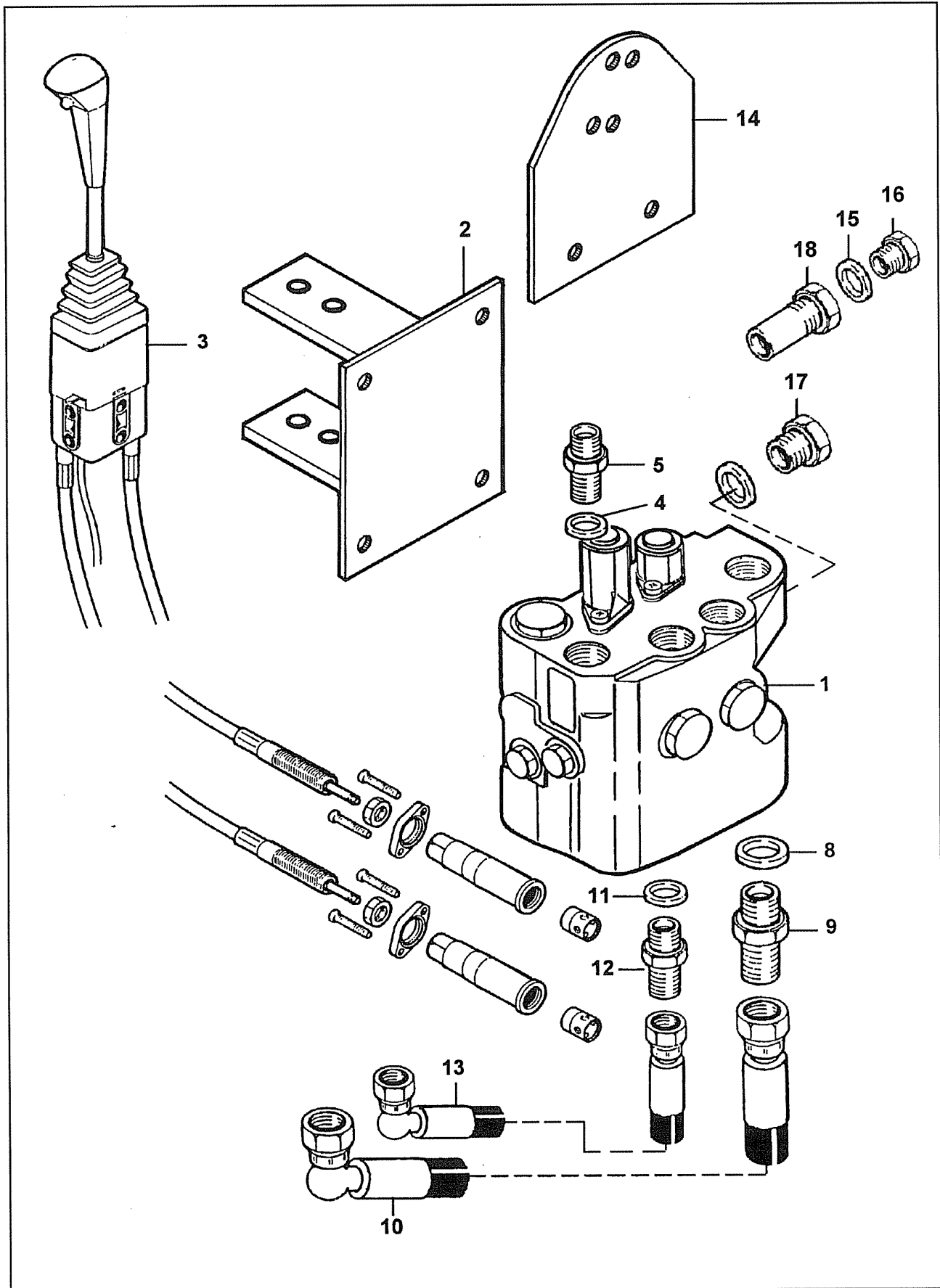

REF	PART NO	DESCRIPTION	QTY
76.436.01 VALVE ASSY OC MONOBLOC			
01	41.101.01	CONTROL VALVE OC MONOBLOCK	1
*02	43027.01	BRACKET VALVE MOUNTING	1
02	42815.02	SPACER	1
02	05.264.01	SETSCREW M8 X 20MM PLATED	4
02	05.282.02	SPRING WASHER 10MM PLATED	1
02	05.286.02	NUT M10 PLATED	1
02	05.292.15	BOLT M10 X 120MM PLATED	1
*03	41.184.07	CABLE ASSY - DUAL AXIS NON ELEC	1
03	41.184.04	CABLE END SERVICE KIT	-
04	05.290.05	BONDED SEAL 1/2"BSP	4
*05	01.099.03	ADAPTOR 1/2BSP X 1/4BSP	4
05	05.300.01	PLUG-PLASTIC 1/4"BSP FEMALE	4
06	05.290.05	BONDED SEAL 1/2"BSP	5
08	05.290.06	BONDED SEAL 3/4"BSP	1
09	05.377.01	ADAPTOR 3/4"BSP X 3/4"BSP	1
10	10.010.32	HOSE 3/4"BSP ST X 90 S.SEAL 2200	1
11	05.290.05	BONDED SEAL 1/2"BSP	1
*12	05.122.01	ADAPTOR 1/2" BSP X 1/2" BSP	1
12	05.300.03	PLUG-PLASTIC 1/2"BSP FEMALE	1
13	10.006.32	HOSE 1/2"BSP ST X 90 S.SEAL 2200	1
*14	42294.01	PLATE JOYSTICK MOUNTING	1
14	05.282.01	SPRING WASHER 8MM PLATED	2
14	05.286.01	NUT M8 PLATED	2
14	05.292.01	BOLT M8 X 80MM PLATED	2
15	05.290.05	BONDED SEAL 1/2"BSP	1
17	05.433.06	PLUG 1/2"BSP PLATED	1
18	41.101.05	ADAPTOR CARRY-OVER FOR KM81	1

***MAIN PART IN GROUP, RELATED PARTS HAVE SAME REFERENCE NUMBER**

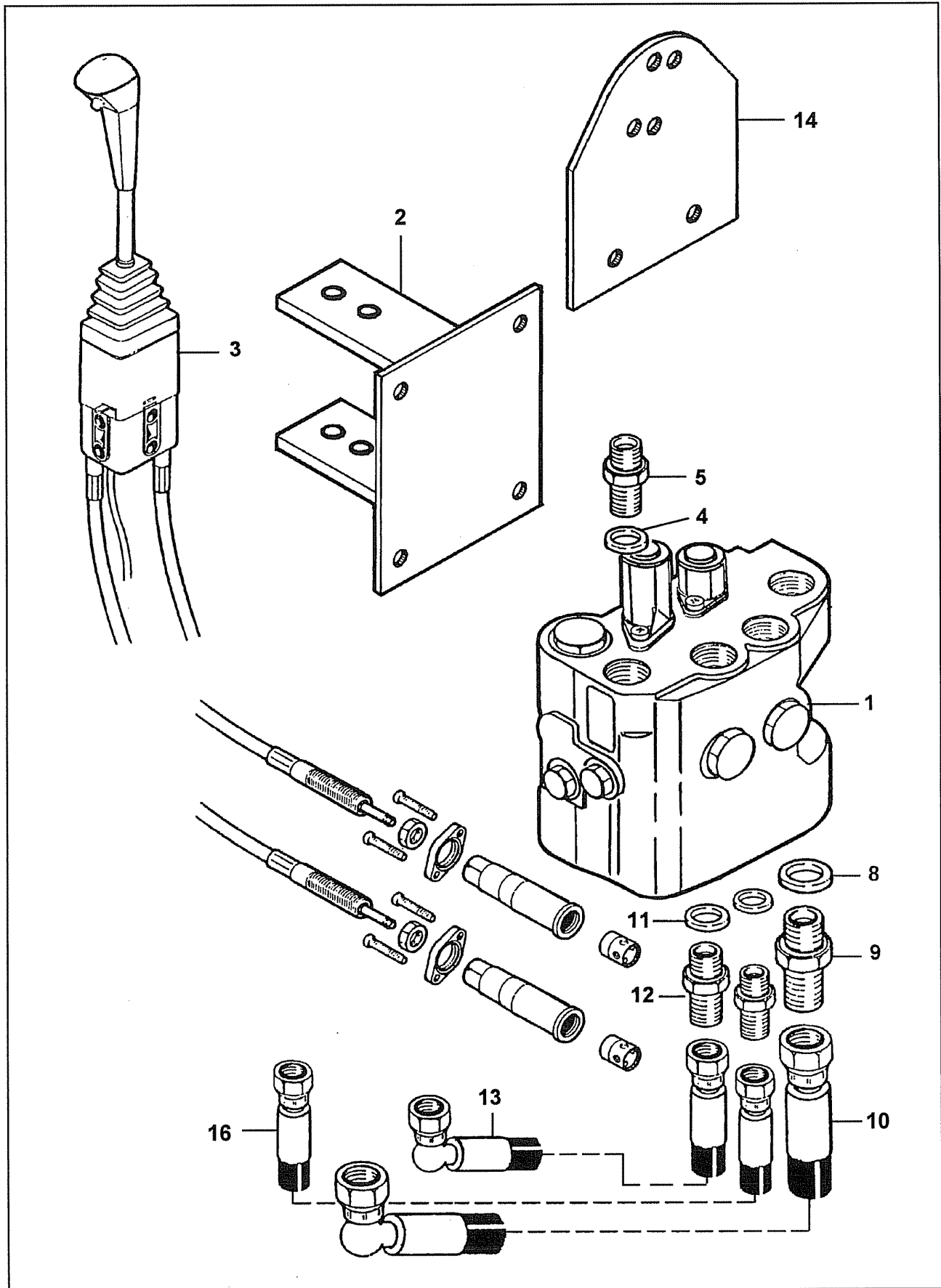

REF	PART NO	DESCRIPTION	QTY
76.436.02 VALVE ASSY LOAD SENSING MONOBLOC			
*01	41.101.02	CONTROL VALVE - LS MONOBLOCK	1
01	05.290.05	BONDED SEAL 1/2"BSP	1
01	05.433.06	PLUG 1/2"BSP PLATED	1
*02	43027.01	BRACKET VALVE MOUNTING	1
02	42815.02	SPACER	1
02	05.264.01	SETSCREW M8 X 20MM PLATED	4
02	05.282.02	SPRING WASHER 10MM PLATED	1
02	05.286.02	NUT M10 PLATED	1
02	05.292.15	BOLT M10 X 120MM PLATED	1
*03	41.184.07	CABLE ASSY - DUAL AXIS NONELEC	1
03	41.184.04	CABLE END SERVICE KIT	-
04	05.290.05	BONDED SEAL 1/2"BSP	4
*05	01.099.03	ADAPTOR 1/2 BSP X 1/4BSP	4
05	05.300.01	PLUG-PLASTIC 1/4"BSP FEMALE	4
06	05.290.05	BONDED SEAL 1/2"BSP	5
08	05.290.06	BONDED SEAL 3/4"BSP	1
09	05.377.01	ADAPTOR 3/4"BSP X 3/4"BSP	1
10	10.010.32	HOSE 3/4"BSP ST X 90 S.SEAL 2200	1
11	05.290.05	BONDED SEAL 1/2"BSP	1
*12	05.122.01	ADAPTOR 1/2" BSP X 1/2" BSP	1
12	05.300.03	PLUG-PLASTIC 1/2"BSP FEMALE	1
13	10.006.32	HOSE 1/2"BSP STX90 S.SEAL 2200	1
*14	42294.01	PLATE JOYSTICK MOUNTING	1
14	05.282.01	SPRING WASHER 8MM PLATED	2
14	05.286.01	NUT M8 PLATED	2
14	05.292.01	BOLT M8 X 80MM PLATED	2
15	30.052.76	1/4" X 1/8" ADAPTOR M/M BSP	1
16	10.001.32	HOSE 1/4"BSP ST X ST S.SEAL 2200	1
17	05.313.01	BLANKING PLUG - 3/4" BSP	1

***MAIN PART IN GROUP, RELATED PARTS HAVE SAME REFERENCE NUMBER**