

Parts Manual for

**WGC No: 7354849**

**120 HEAD ASSY**

Print date: 06/06/2012

Applicable to Works Order No: 88409B

For Serial No: M1227295



**All parts are not created equal and before you settle on an imitation part, know this - McConnel Genuine Parts offer the safety, durability and warranty protection you expect. You've made an investment in your equipment; now invest in its future.**

- We design and build to exact specifications requiring strict chemical strength and performance characteristics. (Never reverse engineered like imitation parts).
- McConnel Genuine Parts meet the rigid guidelines necessary to satisfy warranty requirements.
- Our parts experts are available to answer any questions and have first -hand knowledge of all equipment.
- McConnel Genuine Parts are tested to meet all safety standards.
- McConnel parts have a 6 month warranty when fitted by an authorised Dealer.

## **McCONEL LIMITED**

***For parts supply contact your local Dealer or Stockist***

**To help them help you, always quote:**

- ***Machine Type***
- ***Serial Number***
- ***Part Number***

*Design improvements may alter some of the parts listed in this manual – the latest part will always be supplied when it is interchangeable with an earlier one.*

### **McCONNEL PARTS DEPARTMENT**

**Telephone:** +44 (0)1584 873131 **Fax:** +44 (0)1584 872223  
**Direct Parts Line:** +44 (0)1584 876888 **Email:** parts@mccconnel.com



# CONTENTS

Page No	Schedule No	Schedule Description
3	1093354	CONVEYOR BRIDGE
5	21523.08	ROLLER ASSY
7	21541.01	FLAP KIT
9	22494.48	CASING MODULE
11	22495.26	DRIVE MODULE
13	8301304	HYD MOTOR
15	22496.41	COVER MODULE
17	22497.06	1.2M ROTOR MODULE
19	22498.03	QUAD DRIVE MODULE
21	23030.02	HOSE KIT
23	23149.01	STOP KIT
25	7350709	STICKER MODULE

\* optional component



1093354 - CONVEYOR BRIDGE

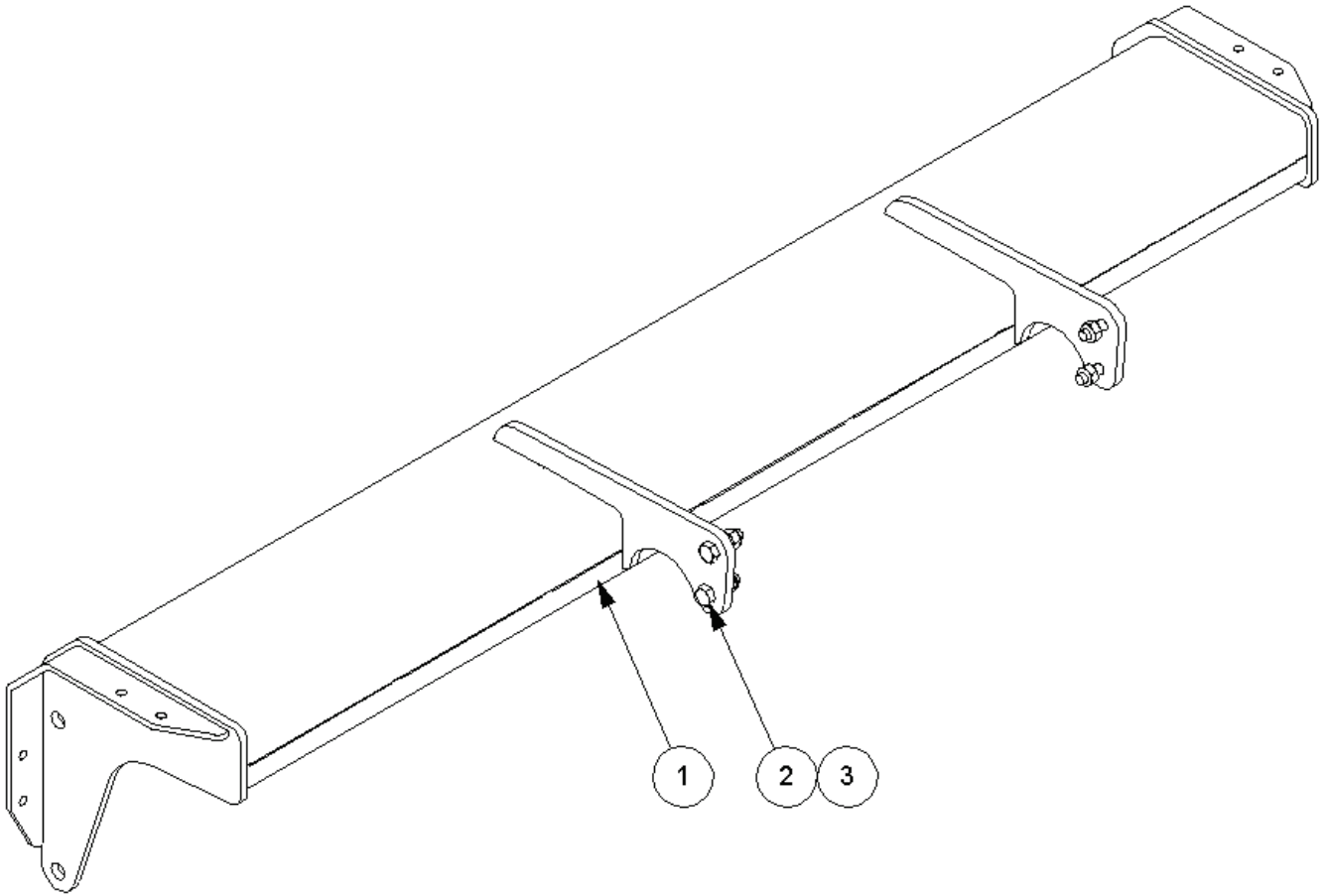

**1093354 - CONVEYOR BRIDGE**

Ref	Part No	Description	Qty
1	22841.01	BRIDGING BRACKET	1
2	9313075	SCREW	4
3	9163005	NUT	4

21523.08 C - ROLLER ASSY

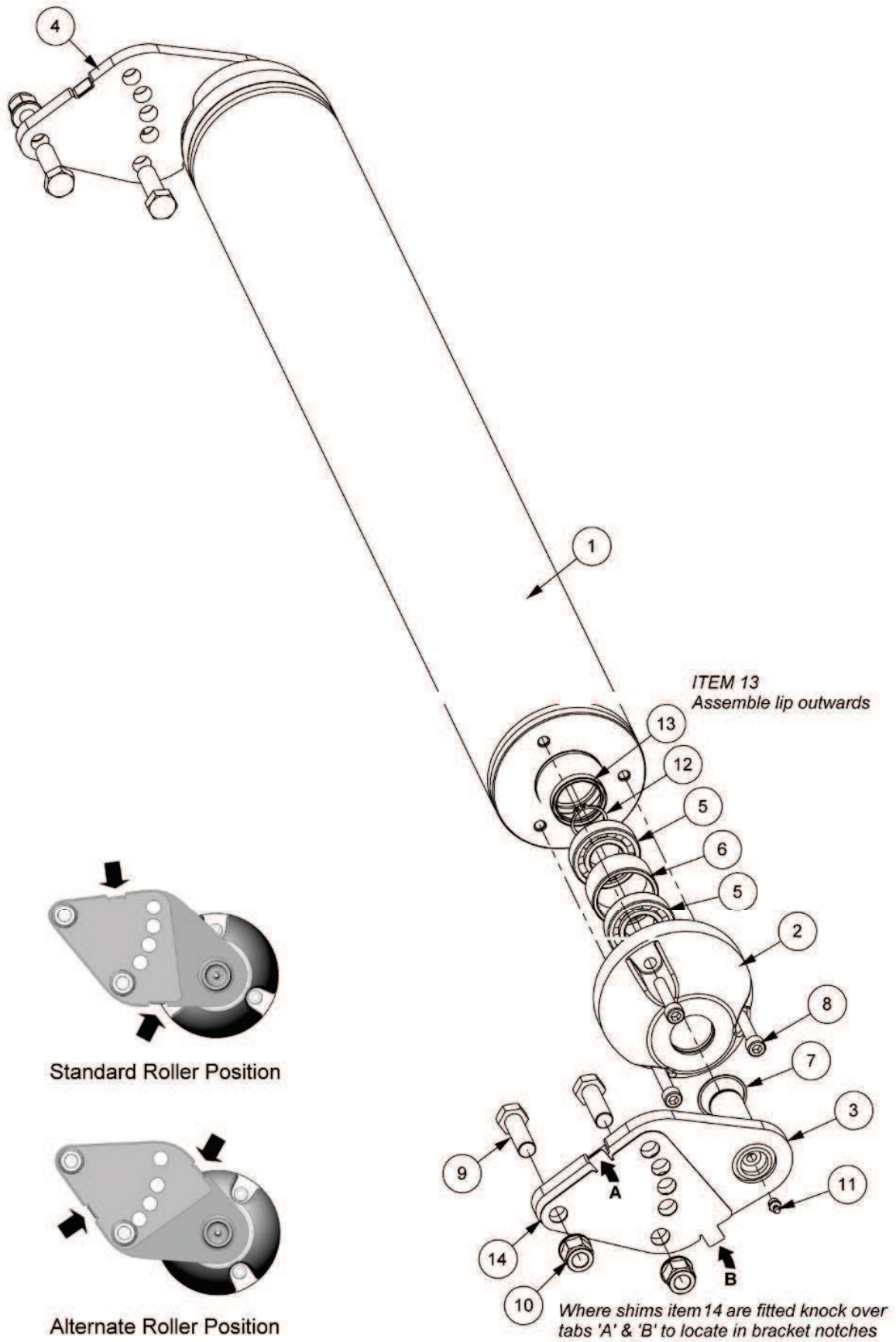



## 21523.08 C - ROLLER ASSY

Ref	Part No	Description	Qty
1	21394.03	ROLLER	1
2	21394.32	CAP	2
3	21524.12	BRACKET	1
4	21524.13	BRACKET	1
5	0600111	BEARING	4
6	21523.31	SPACER	2
7	0402240	RING	2
8	9343105	SCREW	6
9	9200031	BOLT	4
10	9100024	NUT	4
11	0901121	GREASER	2
12	0401230	CIRCLIP	2
13	8629239	SEAL	2
14	42257.10	SHIM	0

21541.01 F - FLAP KIT

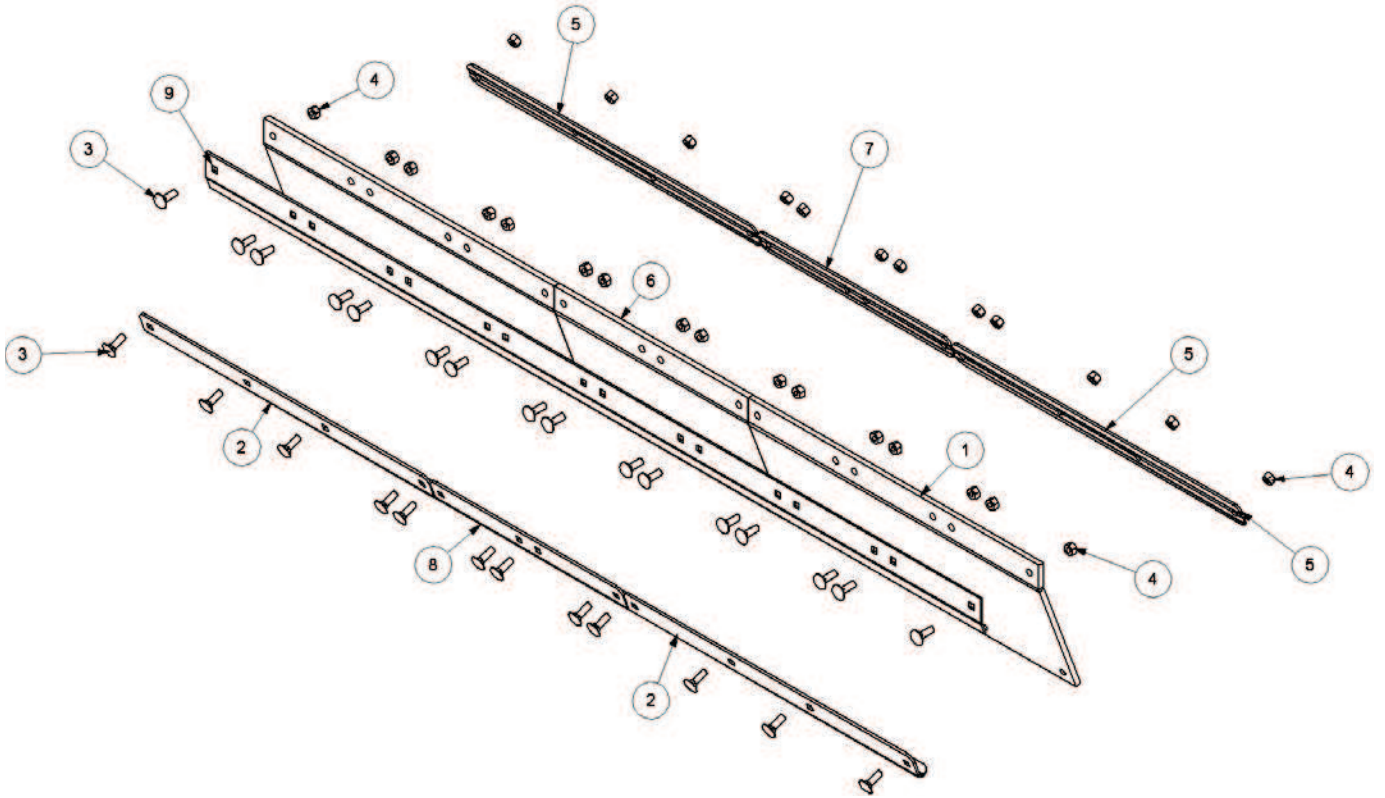

**21541.01 F - FLAP KIT**

Ref	Part No	Description	Qty
1	21544.01	FLAP	2
2	21541.05	PLATE	2
3	9293054	BOLT	28
4	9163004	NUT	28
5	21541.06	PLATE	2
6	21544.02	FLAP	1
7	21541.08	PLATE	1
8	21541.07	PLATE	1
9	7190304	STRIP	1

22494.48 - CASING MODULE

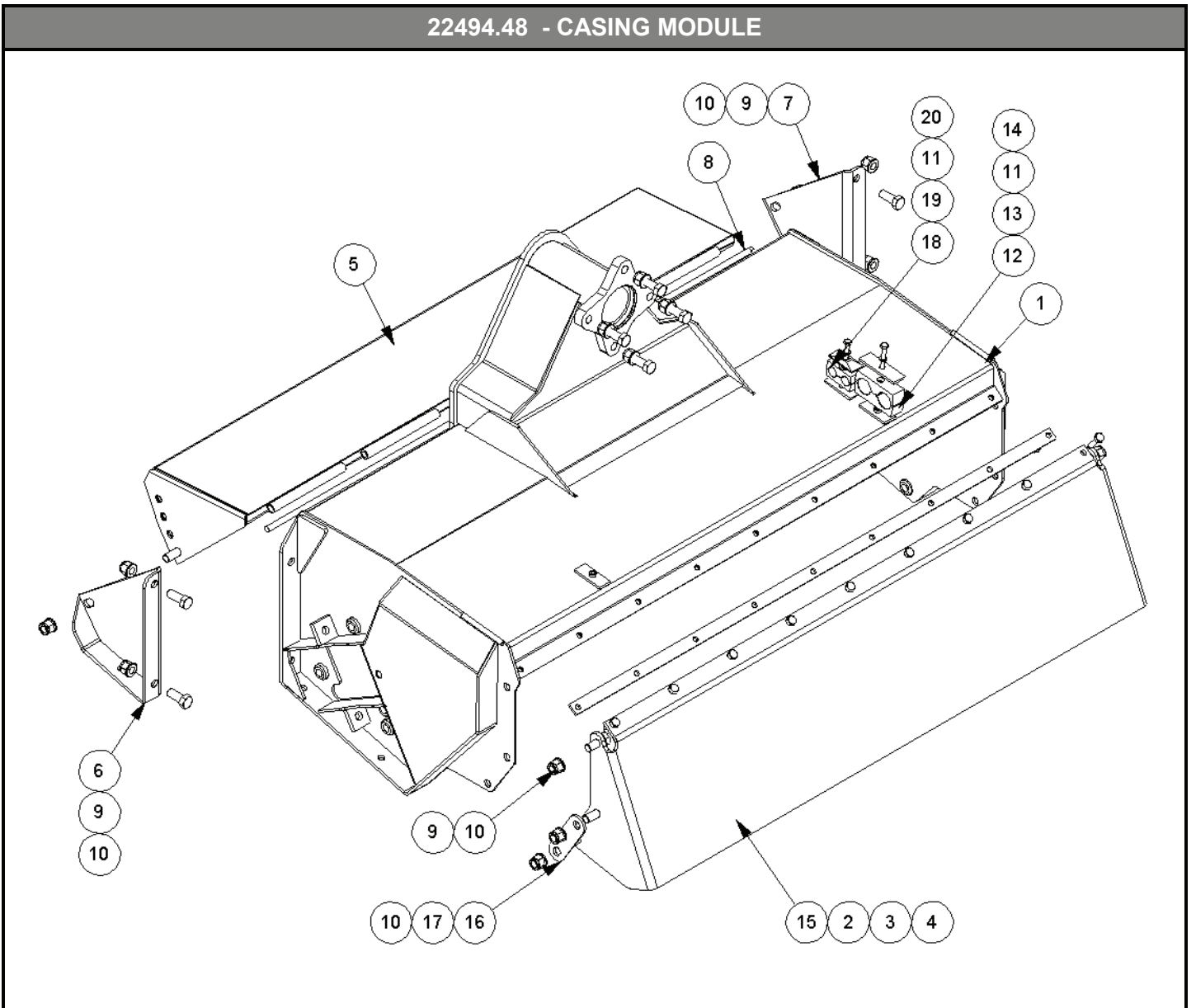

## 22494.48 - CASING MODULE

Ref	Part No	Description	Qty
1	41685.07	CASING W/A	1
2	7190313	PLATE	1
3	9313075	SCREW	9
4	9163005	NUT	9
5	41695.02	FRONT HOOD	1
6	7290388	BRACKET -LH	1
7	7290387	BRACKET -RH	1
8	41700.01	PIN	1
9	30.073.25	BOLT	8
10	9100024	NUT	16
11	9100204	WASHER	2
12	42024.06	CLAMP -2	1
13	06.418.05	PLATE	1
14	9213134	BOLT	1
15	42440.03	REAR RUBBER FLAP	1
16	41289.04	STRAP	2
17	9200028	BOLT	4
18	22616.01	1/2" HOSE CLAMP	1
19	22616.02	HOSE COVER PLATE	1
20	9213104	BOLT	1
21	9200031	BOLT	4

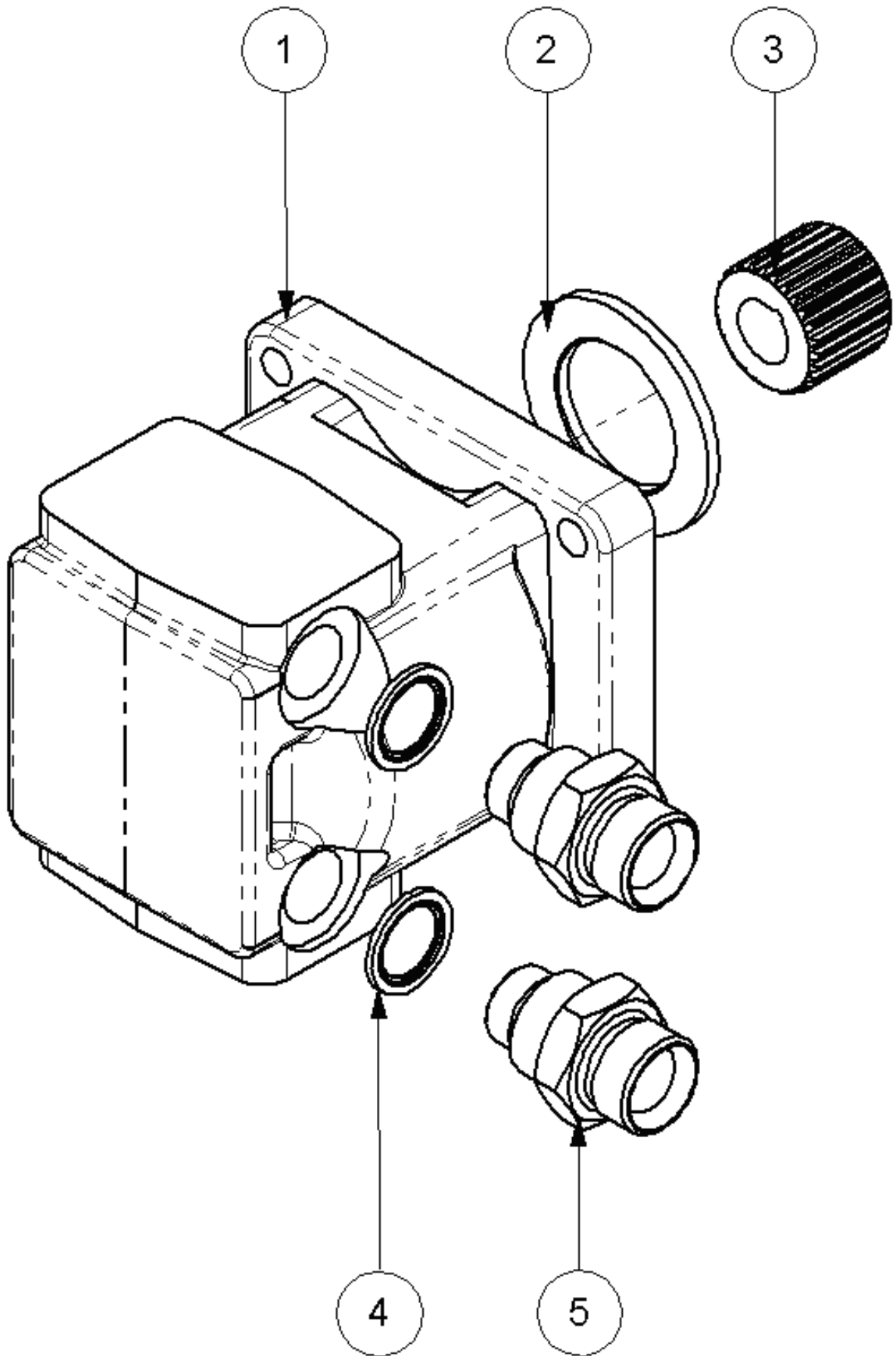

**22495.26 - DRIVE MODULE**

Ref	Part No	Description	Qty
1	8301304	HYD MOTOR	1
2	7190015	WASHER	1
3	43390.02	USE 7190584	1
4	8650106	SEAL	2
5	8581295	ADAPTOR	2

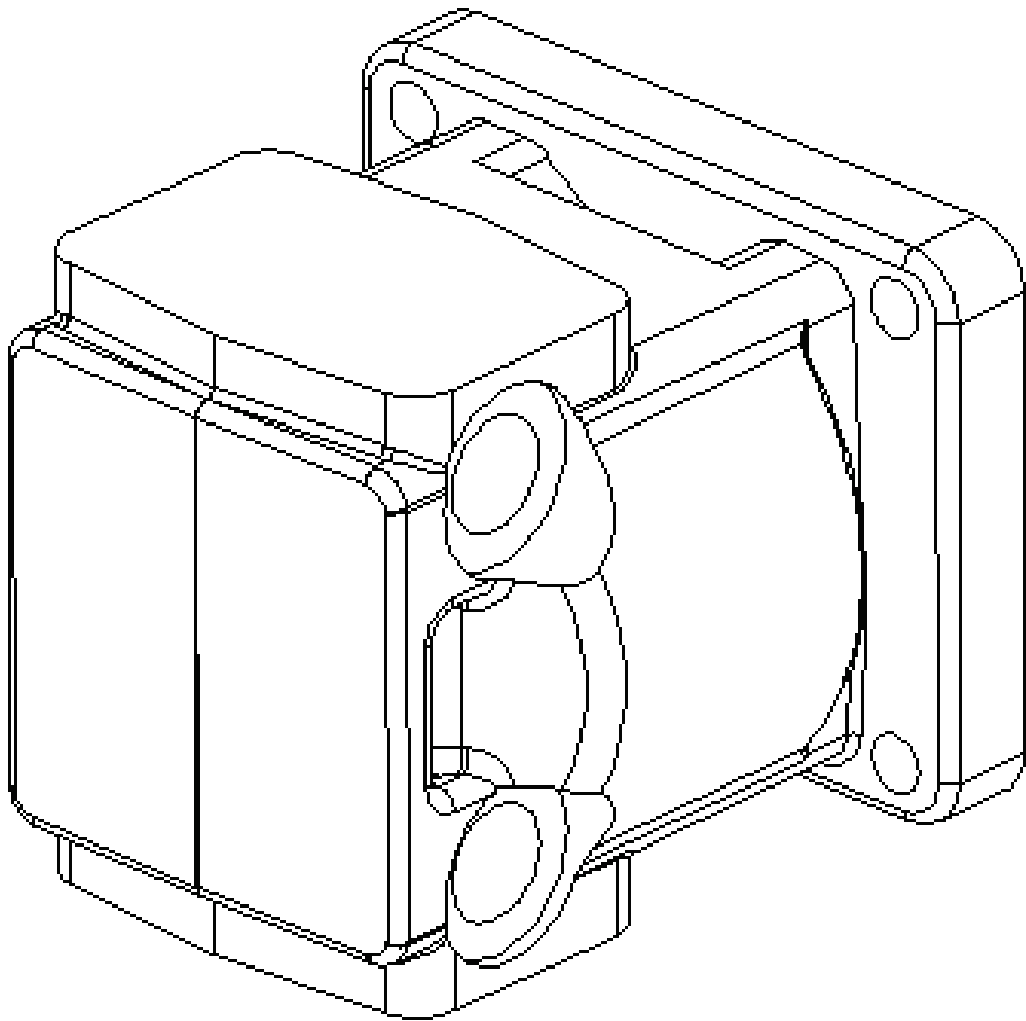



**8301304 - HYD MOTOR**

Ref	Part No	Description	Qty
0	8629209	SEAL	2
0	8699236	SEAL KIT	1
3	8301010	KEY	1
4	9100015	NUT	1

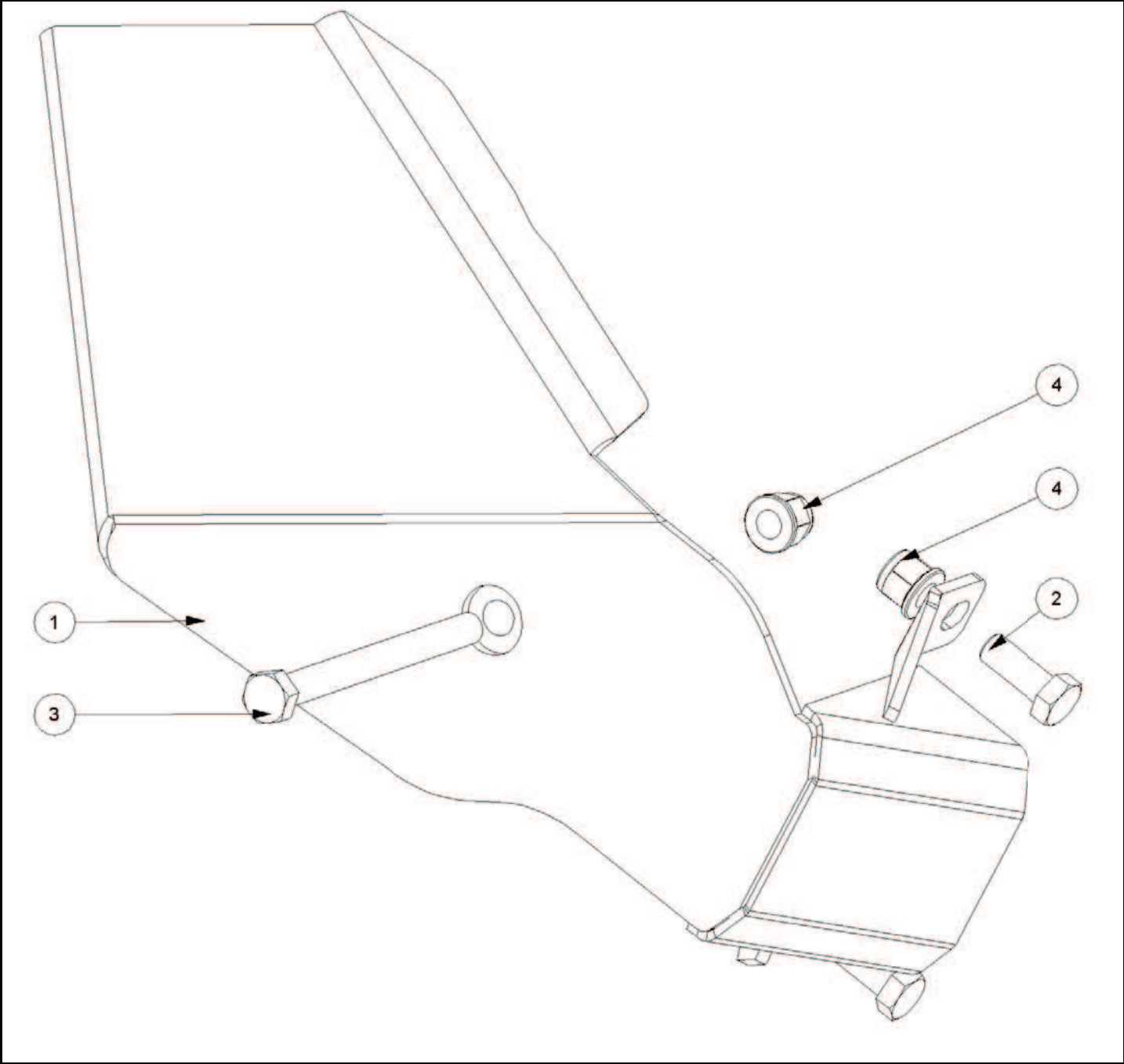

**22496.41 - COVER MODULE**

Ref	Part No	Description	Qty
1	42282.20	COVER W/A	1
2	30.073.25	BOLT	2
3	9200034	BOLT	1
4	9100024	NUT	3

22497.06 B - 1.2M ROTOR MODULE

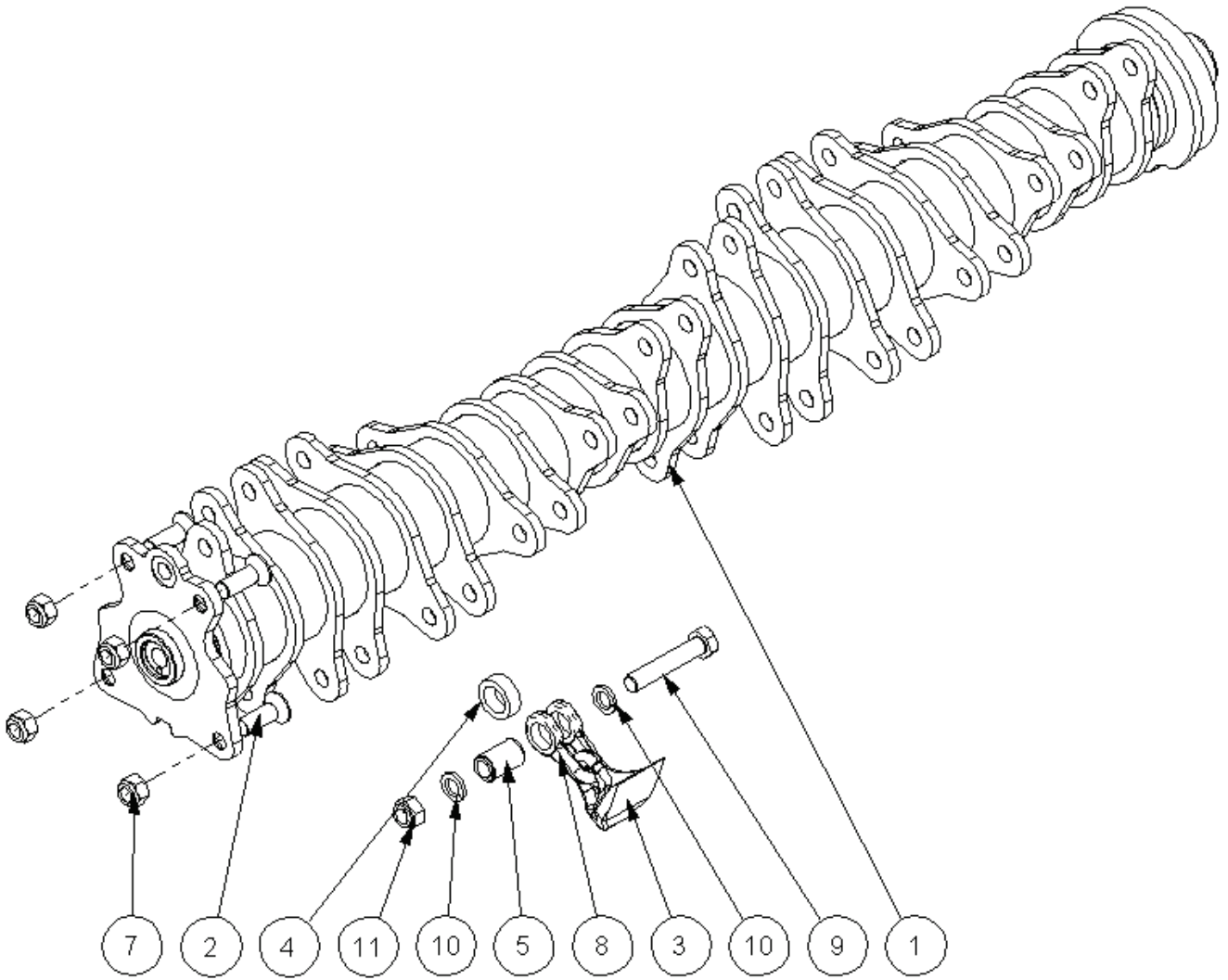

**22497.06 B - 1.2M ROTOR MODULE**

Ref	Part No	Description	Qty
1	22269.01	ROTOR	1
2	9353097	SCREW	4
3	7190462	FLAIL UNI-BOOT	24
4	7190172	SPACER	24
5	7314223	BUSH	24
6	0901161	GREASER	1
7	9163007	NUT	4
8	7190175	SHACKLE	24
9	7314201	BOLT	24
10	0100206	WASHER	48
11	0141006	NUT	24

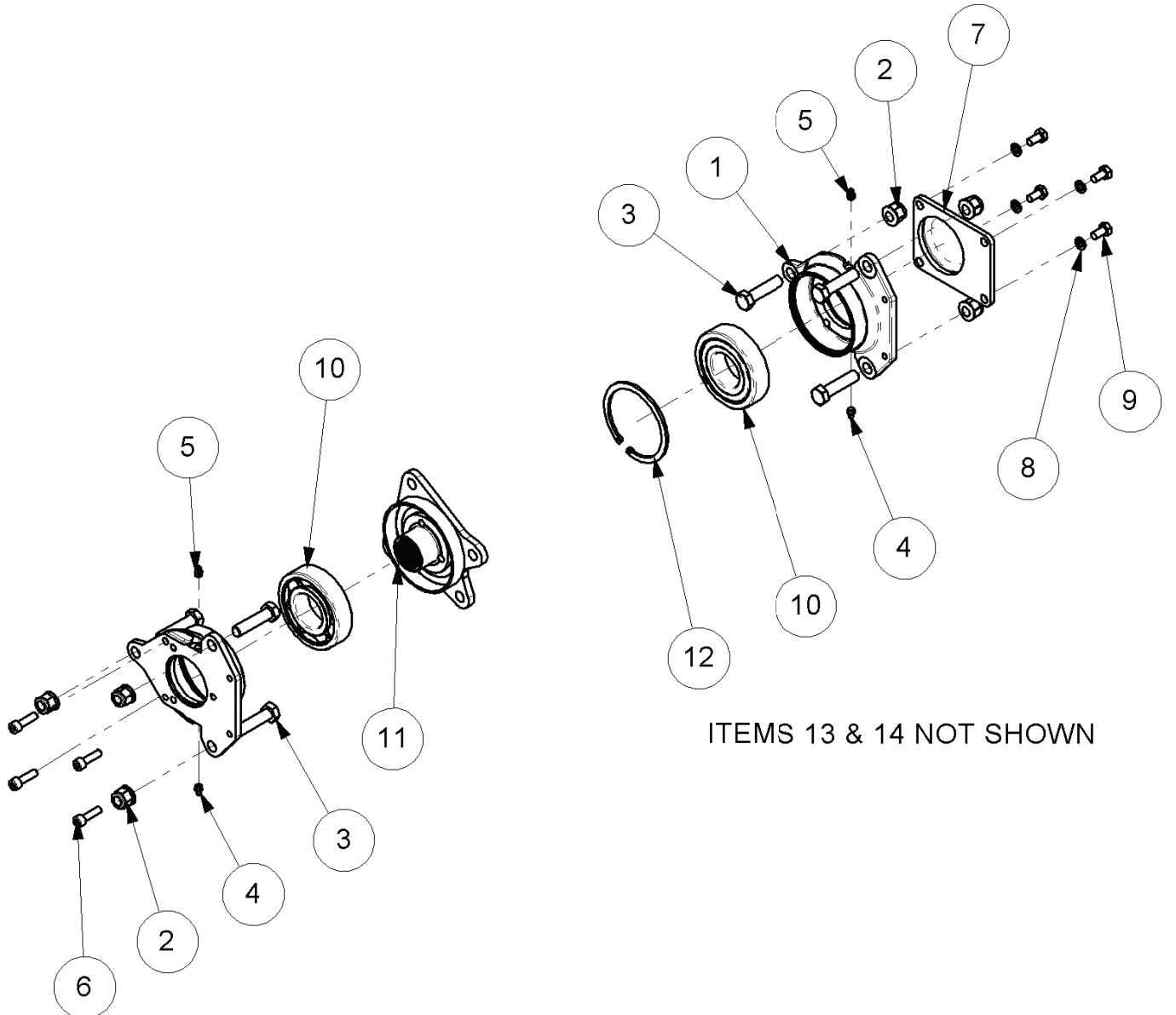

ITEMS 13 & 14 NOT SHOWN

## 22498.03 D - QUAD DRIVE MODULE

Ref	Part No	Description	Qty
1	7190261	HOUSING	2
2	9100024	NUT	6
3	9200024	BOLT	6
4	0901121	GREASER	2
5	0901125	GREASER	2
6	9300144	SCREW	4
7	7190292	PLATE	1
8	9100205	WASHER	4
9	9313045	SCREW	4
10	0600018	BEARING	2
11	22269.02	HUB	1
12	7190022	CIRCLIP	1
13	8121043	SPACER	5
14	8121044	SPACER	5

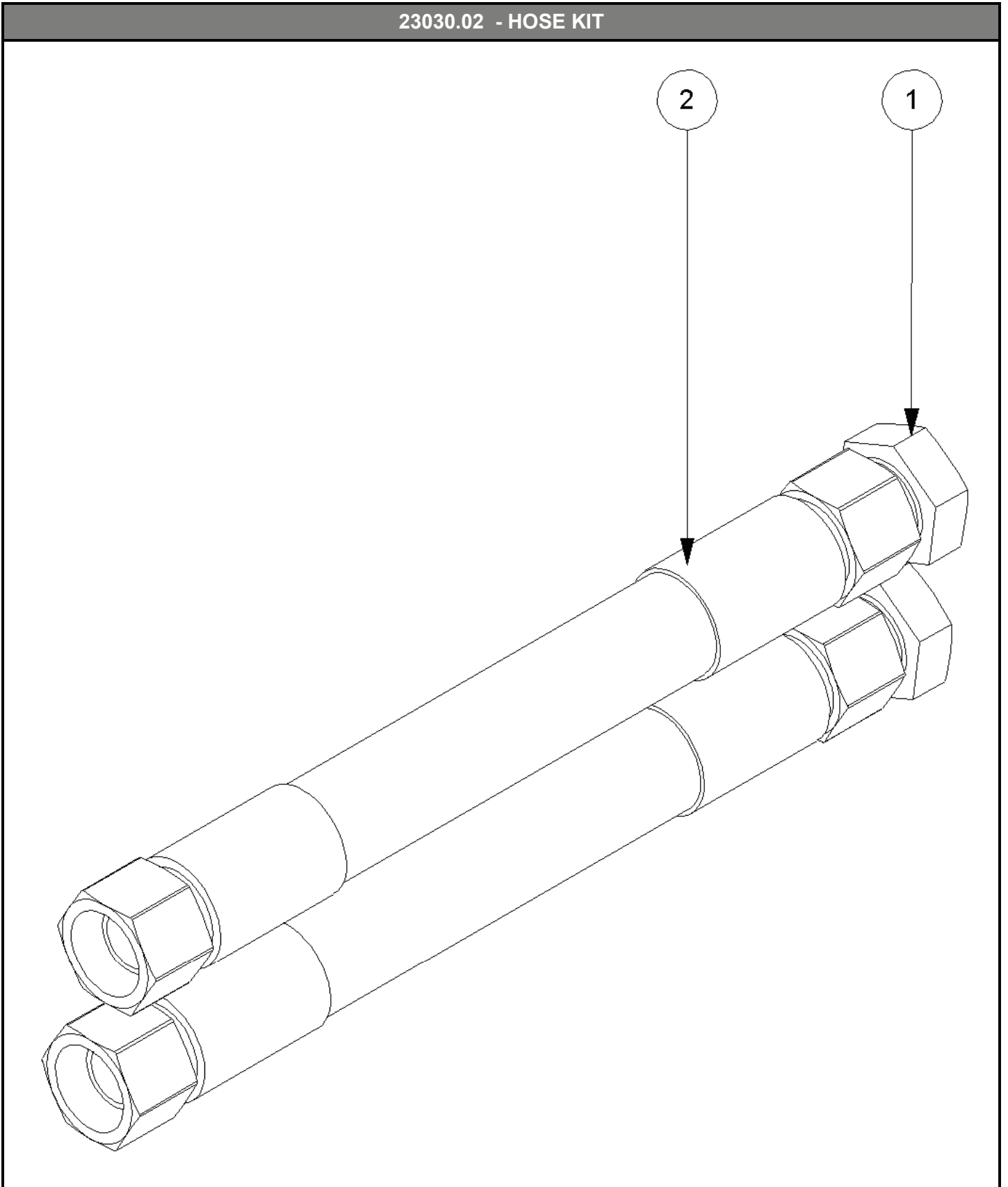



**23030.02 - HOSE KIT**

Ref	Part No	Description	Qty
1	05.433.03	ADAPTOR	2
2	10.011.37	HOSE	2

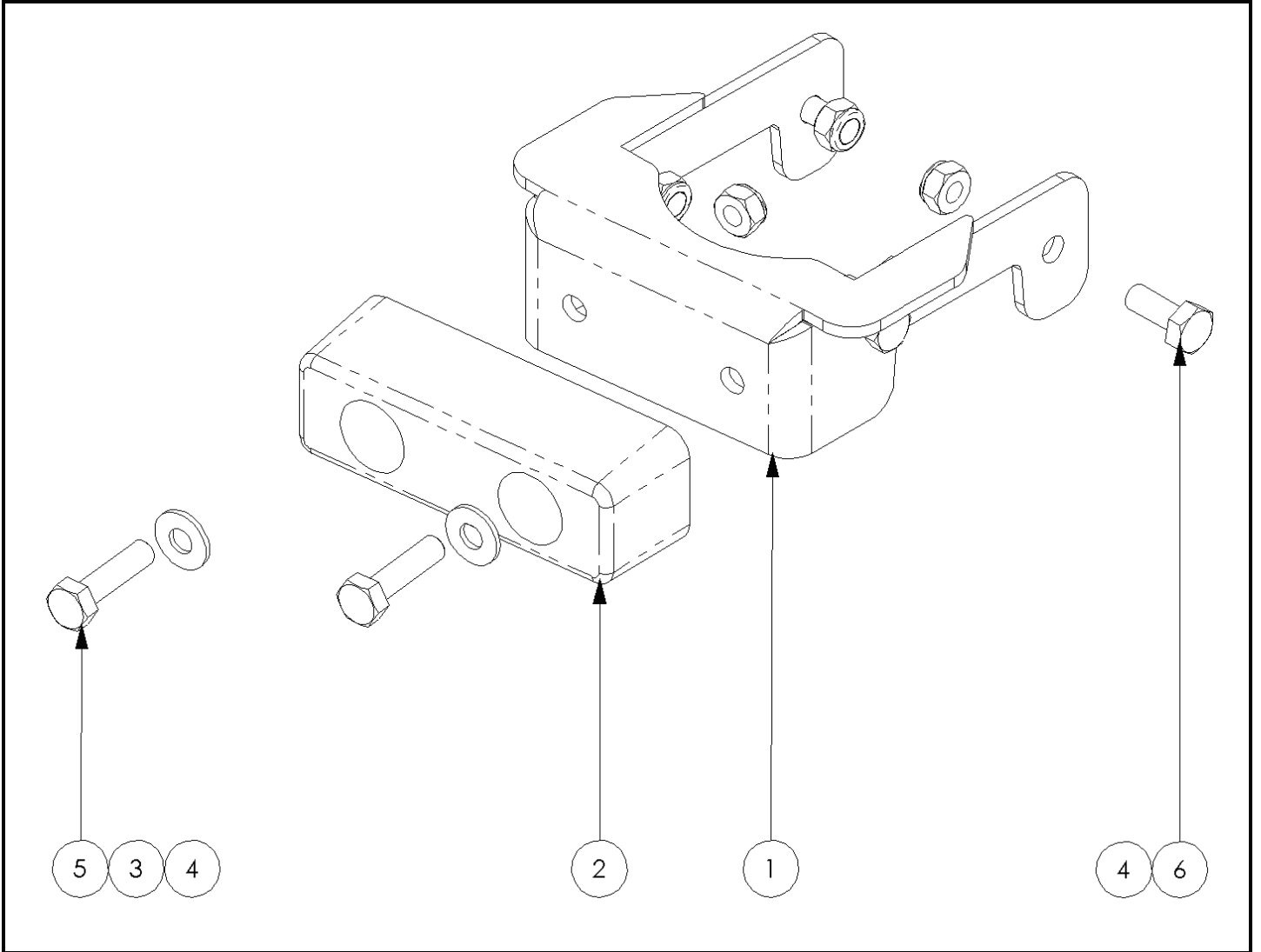

**23149.01 - STOP KIT**

Ref	Part No	Description	Qty
1	23150.01	STOP W/A	1
2	T7879	BUFFER	1
3	9100105	WASHER	2
4	9163005	NUT	6
5	9213085	BOLT	2
6	9313055	SCREW	4



4



8 Hrs

3

**FLAIL PARTS INFORMATION**

McConnel Flail Mowers use dynamically balanced and mated system components for Cutter Shafts, (Rotors) Knives (Flails), Knife hangers (Shackles) bolts, bushes, Rollers, Drivetrain Components, Bearing Belts and Belt Pulleys. McConnel parts are made and tested to meet close-tolerance specifications of balance, quality and consistency that assure long, trouble-free service. "Will-Fit" parts do not ordinarily meet McConnel Standards and could reduce Mower performance, void warranties and present an increase in the safety hazard potential.

**DON'T GAMBLE!**  
USE GENUINE McCONNEL SERVICE PARTS  
See your McConnel dealer

5



7

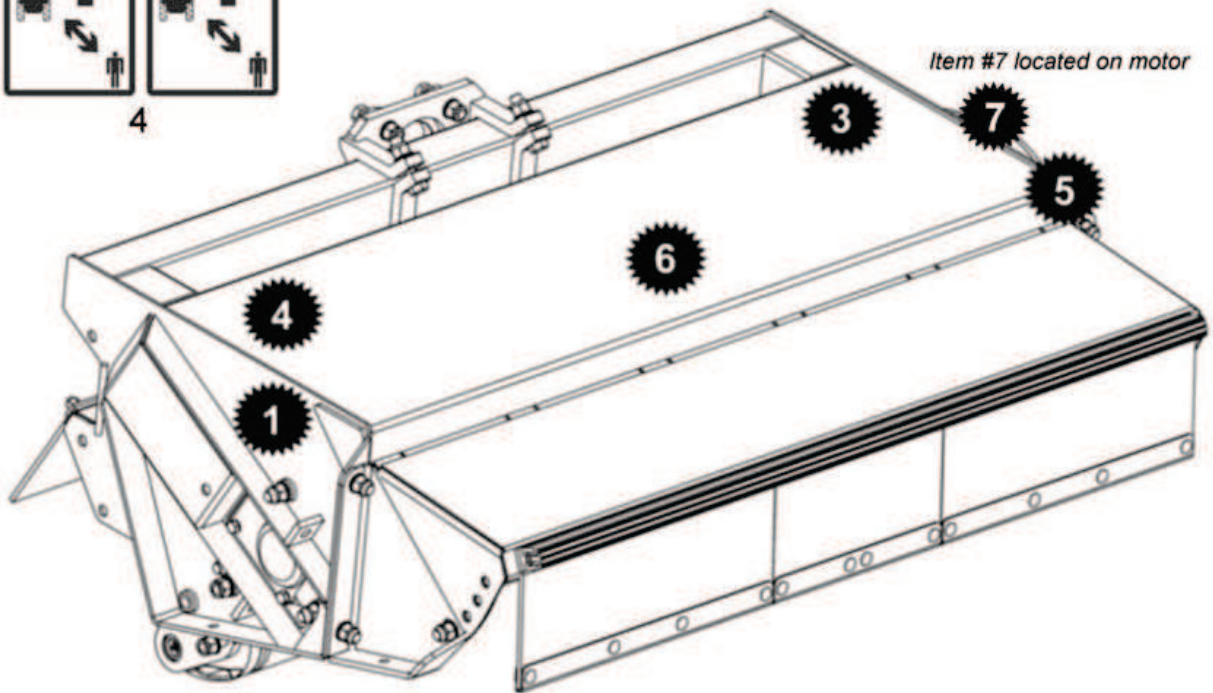

Item #7 located on motor

Flailhead shown is for general illustration purposes only and appearance may differ from your particular model

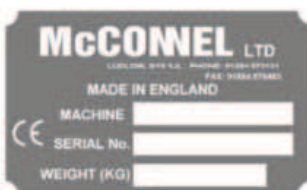

1

**McCONEL**

6

**7350709 - STICKER MODULE**

Ref	Part No	Description	Qty
1	1335246	SERIAL NO.PLATE	1
2	7103230	RIVET	4
3	1290738	DECAL	1
4	09.821.35	DECAL	1
5	1290392	DECAL	1
6	1290527	DECAL	1
7	21917.03	DECAL	1



McConnel Limited, Temeside Works, Ludlow, Shropshire SY8 1JL. England.  
Telephone: 01584 873131. Facsimile: 01584 876463. [www.mcconnel.com](http://www.mcconnel.com)



HERDER BV  
MACHINEFABRIEK  
MIDDELBURG

Groep  
112.02

Transportband  
1,0m, 1,3m, 1,5m, 1,8m en 2,25m

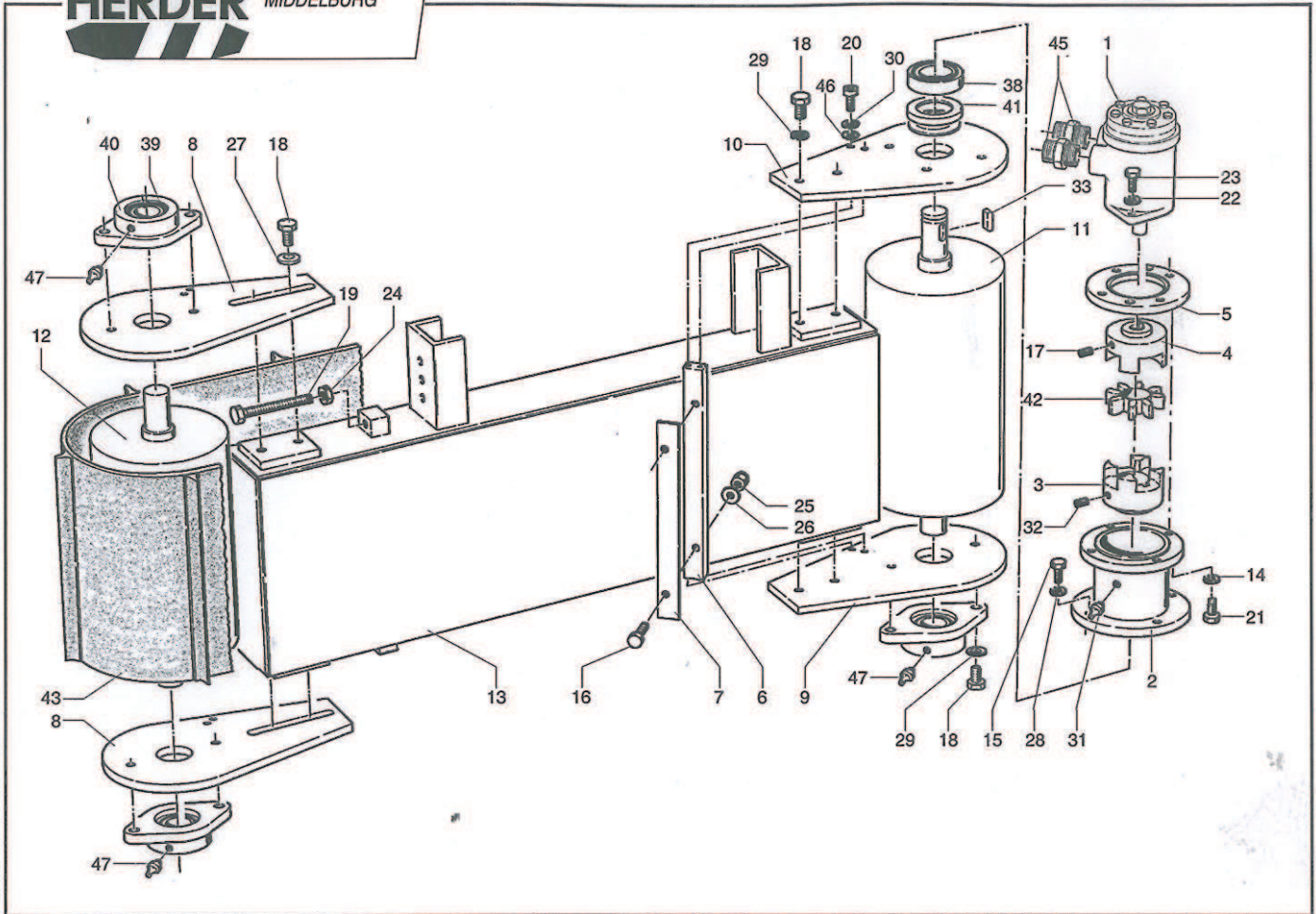

Pos. Nr.	Bestelnr.	Benaming	Aantal					1/2
			100	130	150	180	225	
-	0492.1127	Transportband unit 1,0 m cpl.	1					
-	0492.1006	Transportband unit 1,3 m cpl.		1				
-	0492.1009	Transportband unit 1,5 m cpl.			1			
-	0492.1022	Transportband unit 1,8 m cpl.				1		
-	0492.1023	Transportband unit 2,25 m cpl.					1	
1	9413.1101	Oliemotor as ø25 mm OMP 32 cc HPS	1	1	1	1	1	
2	0023.0301	Koppelingshuis ø132x95	1	1	1	1	1	
3	0024.0339	Koppelingshelft rolzijde ø65xø30x50	1	1	1	1	1	
4	0024.0551	Koppelingshelft motorzijde ø65xø25x48	1	1	1	1	1	
5	0024.0422	Flensplaat ø130x25	1	1	1	1	1	
6	0051.2387	Mesrug van rol schraper 25x12x290	2	2	2	2	2	
7	0053.0243	Mes voor transportrol 25x2x270	2	2	2	2	2	
8	0061.3015	Bevestigingsplaat (verstelbaar)	2	2	2			
	0061.3438	Bevestigingsplaat (verstelbaar)				2	2	
9	0061.3016	Plaat (niet-aangedreven zijde)	1	1	1	1	1	
10	0061.3017	Plaat (aangedreven zijde)	1	1	1	1	1	
11	0492.1003	Aandrijfrol transportband	1	1	1	1	1	
12	0492.1007	Rol t.b.v. transportband	1	1	1	1	1	
13	0492.1123	Frame 1,0 m	1					
	0492.1005	Frame 1,3 m		1				
	0492.1008	Frame 1,5 m			1			
	0492.1020	Frame 1,8 m				1		
	0492.1021	Frame 2,25 m					1	
14	9206.0500	Veerring VR8,1 DIN 7980	4	4	4	4	4	
15	9101.0806	Tapbout M8x22 DIN 933	4	4	4	4	4	
16	9101.0807	Tapbout M8x25 DIN 933	4	4	4	4	4	
17	9112.0803	Stelschroef M8x16 DIN 916	1	1	1	1	1	
18	9101.1006	Tapbout M10x25 DIN 933	14	14	14	14	14	
19	9101.1213	Tapbout M12x70 DIN 933	2	2	2			
	9101.1215	Tapbout M12x80 DIN 933				2	2	
20	9105.0605	Inbusbout M6x20 DIN 912	8	8	8	8	8	
21	9105.0805	Inbusbout M8x25 DIN 912	4	4	4	4	4	
22	9205.1400	Veerring VR12,2 DIN 128A	2	2	2	2	2	
23	9101.1206	Tapbout M12x35 DIN 933	2	2	2	2	2	

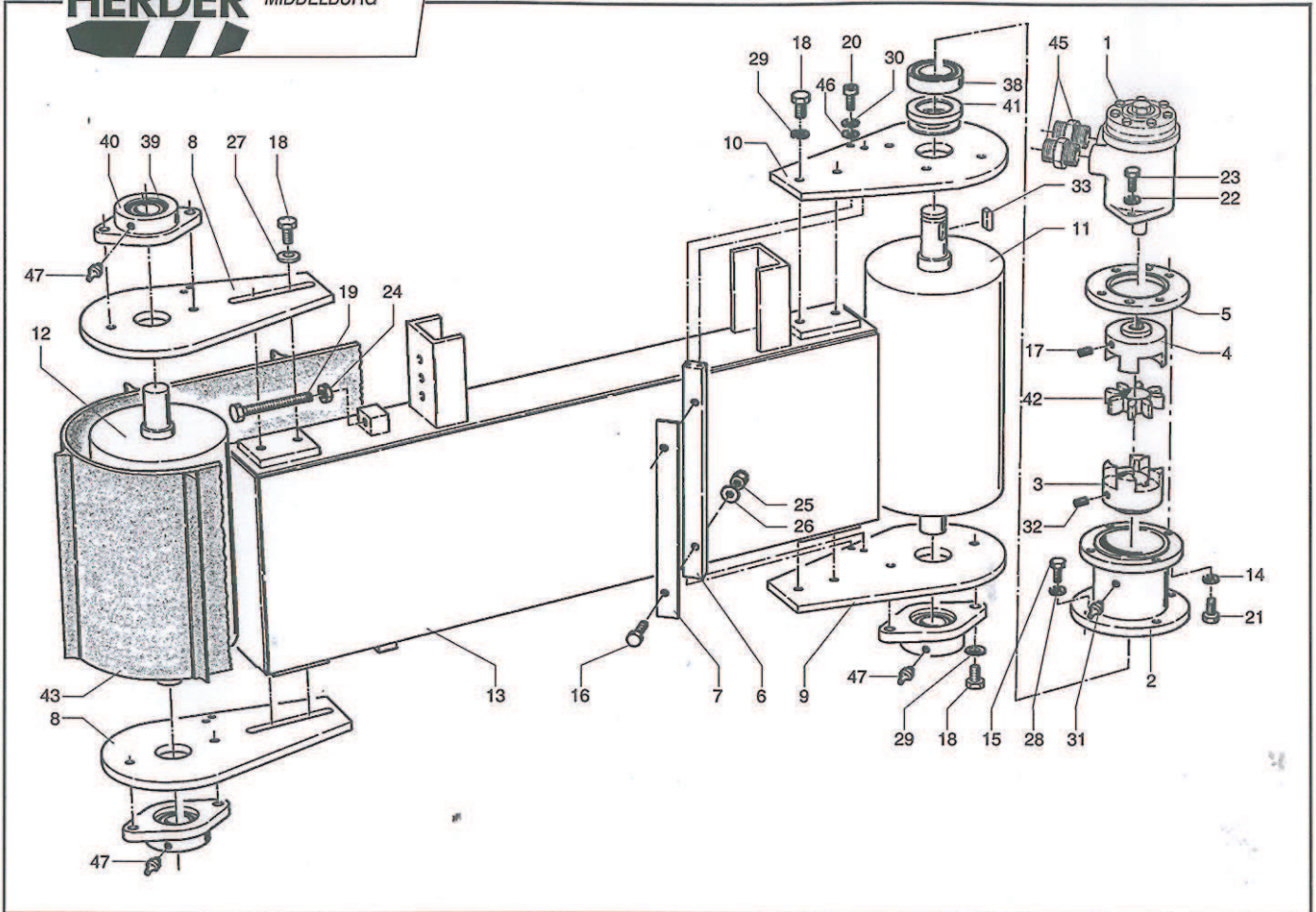

Pos. Nr.	Bestelnr.	Benaming	Aantal					2/2
			100	130	150	180	225	
24	9150.1200	Moer M12 DIN 934	2	2	2	2	2	
25	9154.0800	Borgmoer M8 DIN 985	4	4	4	4	4	
26	9200.0900	Sluitring SR8 DIN 125.1B	4	4	4	4	4	
27	9202.1500	Zware sluitring SR10 DIN 7349	4	4	4	4	4	
28	9205.1000	Veerring VR8,2 DIN 128A	4	4	4	4	4	
29	9205.1200	Veerring VR10,2 DIN 128A	14	14	14	14	14	
30	9206.0300	Veerring VR6,1 DIN 7980	8	8	8	8	8	
31	9310.0008	Smeemoppel recht M10	1	1	1	1	1	
32	9112.0802	Stelschroef M8x12 DIN 916	1	1	1	1	1	
33	9256.0801	Spie 8x7x25	1	1	1	1	1	
38	9500.2051	Groefkogellager 6206 ø62xø30x16	1	1	1	1	1	
39	9500.2070	Lager YAR206.2RF	3	3	3	3	3	
40	9501.0012	Lagerhuis FYTB506M (incl. pos. 47)	3	3	3	3	3	
41	9501.2061	Labyrinthring Z206 ø62xø30x6	1	1	1	1	1	
42	9510.5013	Tandkrans A28 64 D-H groen	1	1	1	1	1	
43	9590.0220	Transportband groen 1,0 m (11 meenemers)	1					
	9590.0221	Transportband groen 1,3 m (13 meenemers)		1				
	9590.0222	Transportband groen 1,5 m (17 meenemers)			1			
	9590.0223	Transportband groen 1,8 m (18 meenemers)				1		
	9590.0224	Transportband groen 2,25 m (23 meenemers)					1	
45	9300.1014	Inschroefkoppeling 1/2"-15 mm	2	2	2	2	2	
46	9200.0600	Sluitring SR6 DIN 125.1B	8	8	8	8	8	
47	9310.0001	Smeemoppel recht M6	3	3	3	3	3	



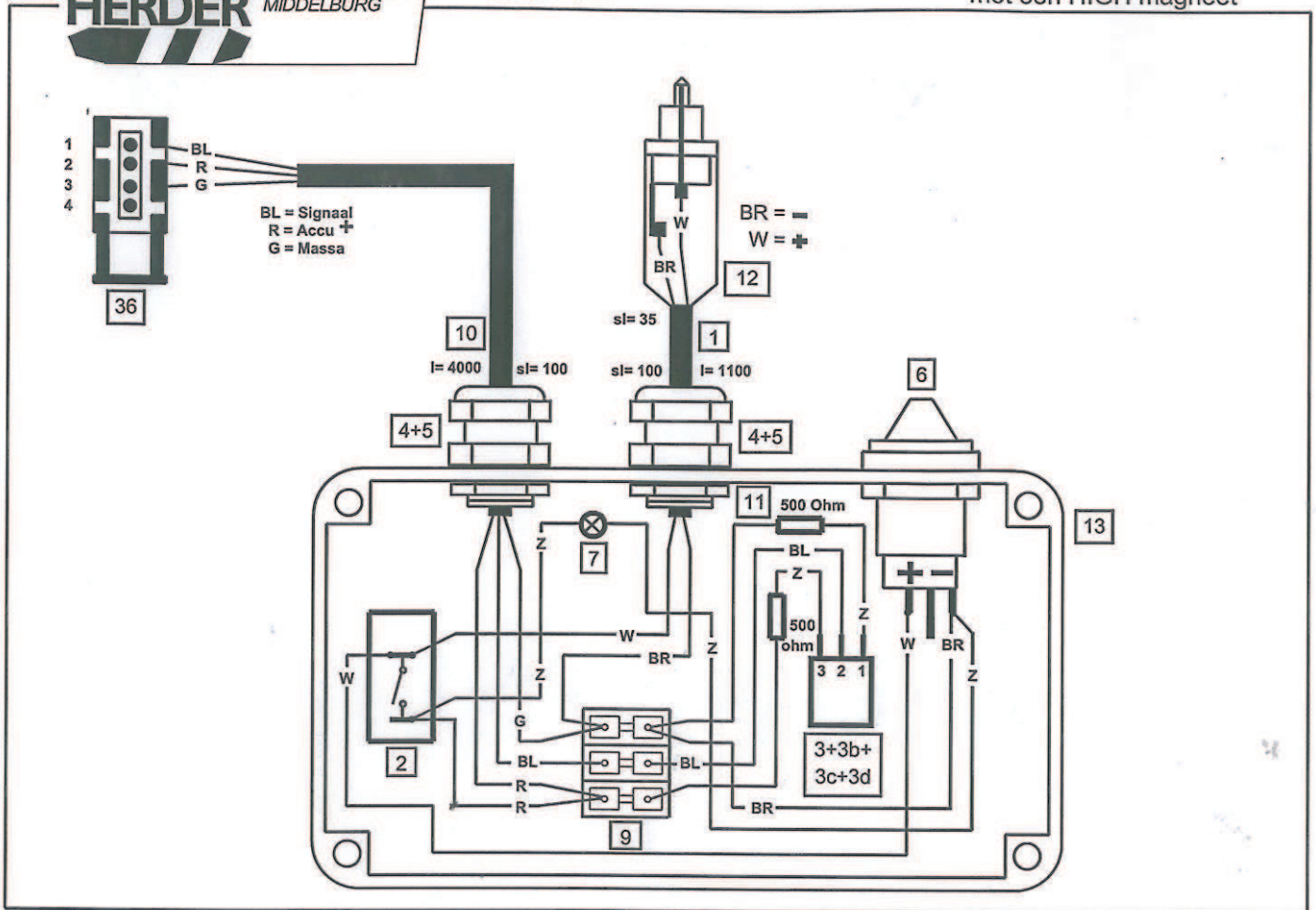

Pos. Nr.	Bestelnr.	Benaming	Aantal	1/1
-	1289.1017	Bedieningskast transportband/vijzel met een HIGH magneet	1	
1	9900.5000	Kabel 2x1 mm <sup>2</sup> wit-bruin	1,1m	
2	9602.0007	Schakelaar 0-1	1	
3	9606.0004	Potentiometer 1K	1	
3 b	9606.9003	Knop	1	
3 c	9606.9004	Knopdeksel	1	
3 d	9606.9002	Knoppijl	1	
4	9610.0202	Pakkingdrukker PG7 MS 1gts. ø 3-6,5mm	2	
5	9610.0300	Pakkingdrukkermoer PG7	2	
6	9603.1051	Stopcontact	1	
7	0799.1076	LED rood	1	
9	9605.5008	Draadverbinder	1	
10	9603.2019	Aansluitkabel + AMP-JPT stekker cpl. blauw + rood + geel	4,0m	
11	9606.0506	Weerstand 600 W - 500 Ohm	2	
12	9603.0050	Steker	1	
13	0081.0464	Aluminium kast	1	
36	-----	Steker transportband/vijzel	1	
-	9904.0450	Sticker Bedieningspaneel	1	
		Kabel of stekker 36, merken met een wikkelsticker		

I	Kabel afknijplengte
sl	Kabel afstriplengte
BL	Kabel blauw
BR	Kabel bruin
G	Kabel geel
R	Kabel rood
W	Kabel wit
Z	Kabel zwart

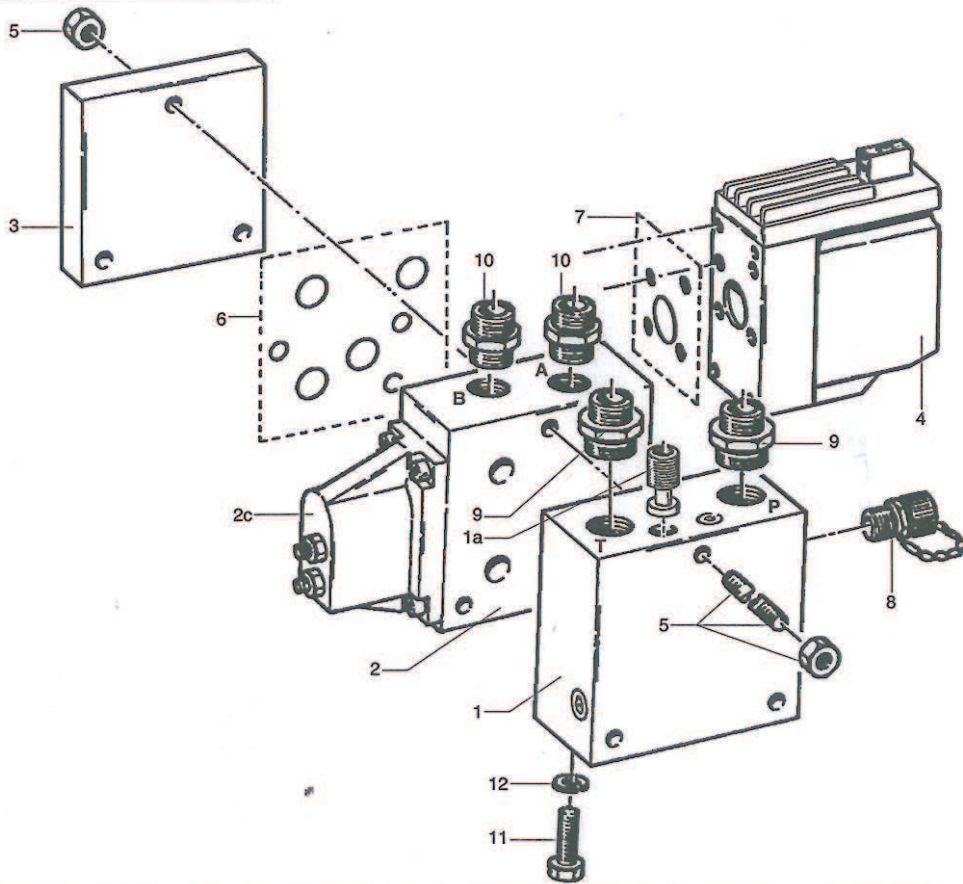

Pos. Nr.	Bestelnr.	Benaming	Aantal	1/1
-	9422.5118	Ventielenblok D.1S Elektrisch (tot 65 L/min) (pos. 1-5)	-	
1	9332.4003	Inlaatsectie	1	
1a	9332.4432	Instelbare hoofdveiligheid PVG 32 (nog afstellen op 170 Bar)	1	
2	-----	Transportbandsectie (pos. 2a, 2b, 2c)		
2a	9332.4301	Sectie ZP/CV	1	
2b	9332.4211	Plunjer E/M65 : 65 L/min.	1	
2c	9332.4401	Handbedieningsset cpl. 1 sectie	1	
3	9332.4005	Eindplaat	1	
4	9332.4429	Proportionele HIGH magneet 11-32 Volt AMP-JPT	1	
5	9140.0041	Trekboutenset 1 sectie	1	
6	9358.3012	O-ring set (tussen pos. 1 en 2 en tussen 2 en 3)	2	
7	9358.3017	O-ring set (tussen pos. 2 en 4)	1	
8	9304.5105	Meetpunt 1/4" (pers)	1	
9	9300.1015	Inschroefkoppeling 3/4"-15mm (pers en retour)	2	
10	9300.1014	Inschroefkoppeling 1/2"-15mm (uitgangen)	2	
11	9101.0805	Tapbout M8x20 DIN 933 (montage)	4	
12	9205.1000	Veerring VR 8,2 DIN 128A (montage)	4	



**Proportioneel Ventiel PVG 32**  
**Calculatie**

PVG nr:

**9422-5118**

Subsidiary/Dealer

klant

applicatie

functie	A-port	0	157B	5110	B-port
		p=	150 bar	157B	
TRB	a 157B <b>4035</b>	1	157B <b>6100</b>	157B <b>7103</b>	13 157B <b>3171</b>
	b 157B		LSa bar	LSb bar	157B
	a 157B	2	157B	157B	13 157B
	b 157B		LSa bar	LSb bar	157B
	a 157B	3	157B	157B	13 157B
	b 157B		LSa bar	LSb bar	157B
	a 157B	4	157B	157B	13 157B
	b 157B		LSa bar	LSb bar	157B
	a 157B	5	157B	157B	13 157B
	b 157B		LSa bar	LSb bar	157B
	a 157B	6	157B	157B	13 157B
	b 157B		LSa bar	LSb bar	157B
	a 157B	7	157B	157B	13 157B
	b 157B		LSa bar	LSb bar	157B
	a 157B	8	157B	157B	13 157B
	b 157B		LSa bar	LSb bar	157B
	a 157B	9	157B	157B	13 157B
	b 157B		LSa bar	LSb bar	157B
	a 157B	10	157B	157B	13 157B
	b 157B		LSa bar	LSb bar	157B
		11	157B	<b>2000</b>	
		12	157B	<b>8001</b>	
Ingevuld door:	<b>A.M.</b>			Datum	<b>18-12-2008</b>