

Publication 172
July 1992
Part No. 71.93.858

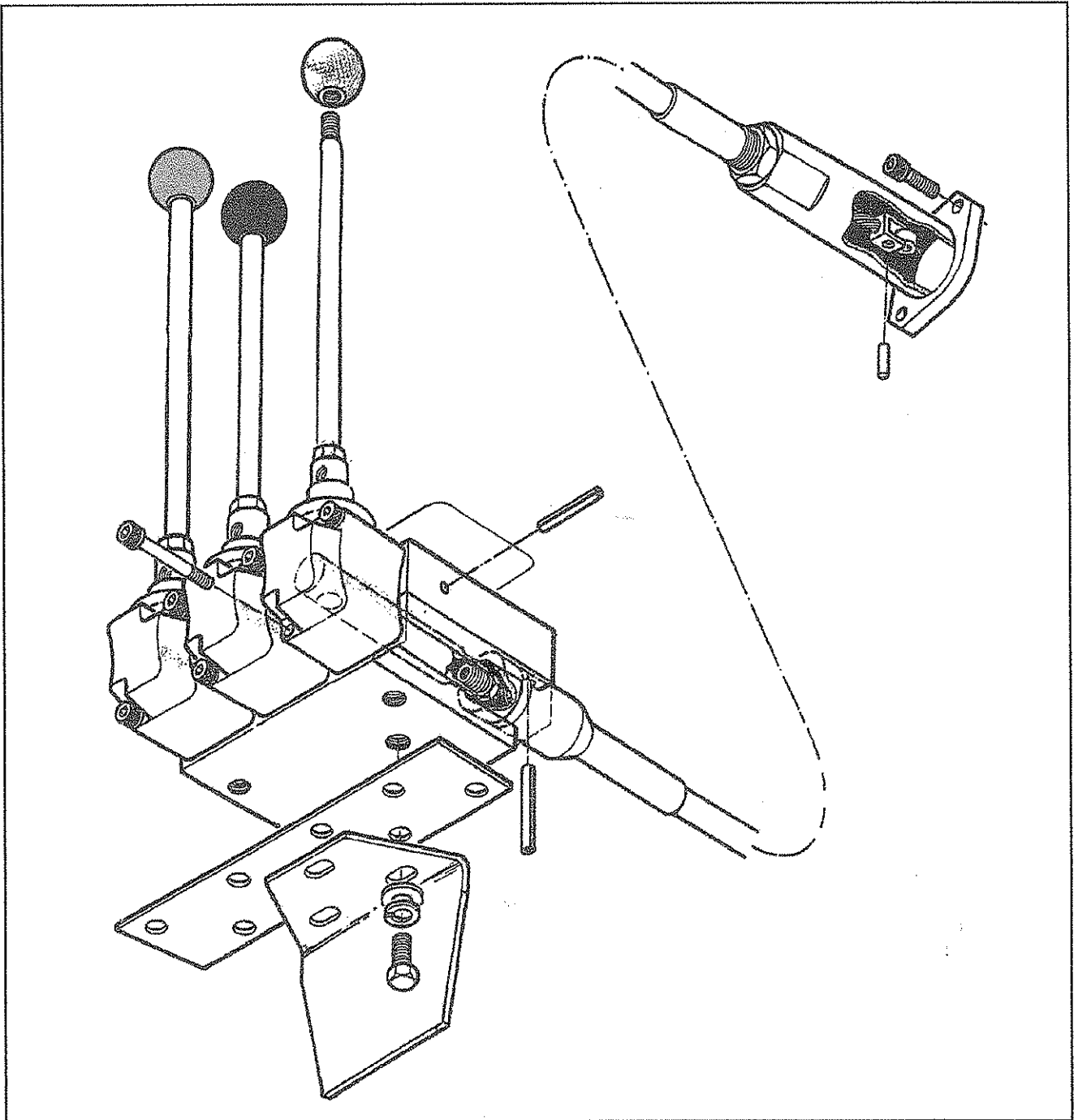

PA 93 *'Classic'* Parts Manual



McCONEL

For best performance...

USE ONLY McCONNEL SERVICE PARTS

To be assured of the latest design improvements purchase your 'Genuine Replacements' from the Original Equipment Manufacturer: McCONNEL LIMITED through your local Dealer or Stockist.

Always quote:

- Machine Type
- Serial Number
- Part Number

Design Improvements may have altered some of the parts listed in this manual – The latest part will always be supplied when it is interchangeable with an earlier one.

LIST OF CONTENTS

MAIN FRAME ETC	Page 1
MAIN ARM & ROCKER.....	Page 3
STANDARD DIPPER ARM.....	Page 5
MID - CUT DIPPER ARM	Page 7
CONTROL MOUNTING ASSEMBLY	Page 9
CAB GUARD KIT	Page 10
FLAIL HEAD CASING	Page 11
ROTORS & FLAILS.....	Page 15
ROLLER OPTIONS	Page 17
HYDRAULIC INSTALLATIONS	Page 19
Standard arm (T.I.).....	Page 19
Standard arm (S.I.).....	Page 23
Mid - cut arm (T.I.)	Page 27
Mid - cut arm (S.I.)	Page 31
CONTROL VALVE.....	Page 35
CONTROL UNIT AND CABLES	Page 37
GEARBOX/PUMP ASSYS (T.I. only)	Page 39
GEARBOX /PUMP ASSYS (S.I. only)	Page 43
GEARBOX.....	Page 47
ROTOR CONTROL VALVE (T.I. only).....	Page 49
ROTOR RELIEF VALVE (S.I. only)	Page 51
HYDRAULIC TANK ASSY.....	Page 53
LIFT FLOAT KIT	Page 55
LIFT RAM	Page 57
REACH RAM.....	Page 59
ANGLING RAM.....	Page 60
DECALS	Page 61

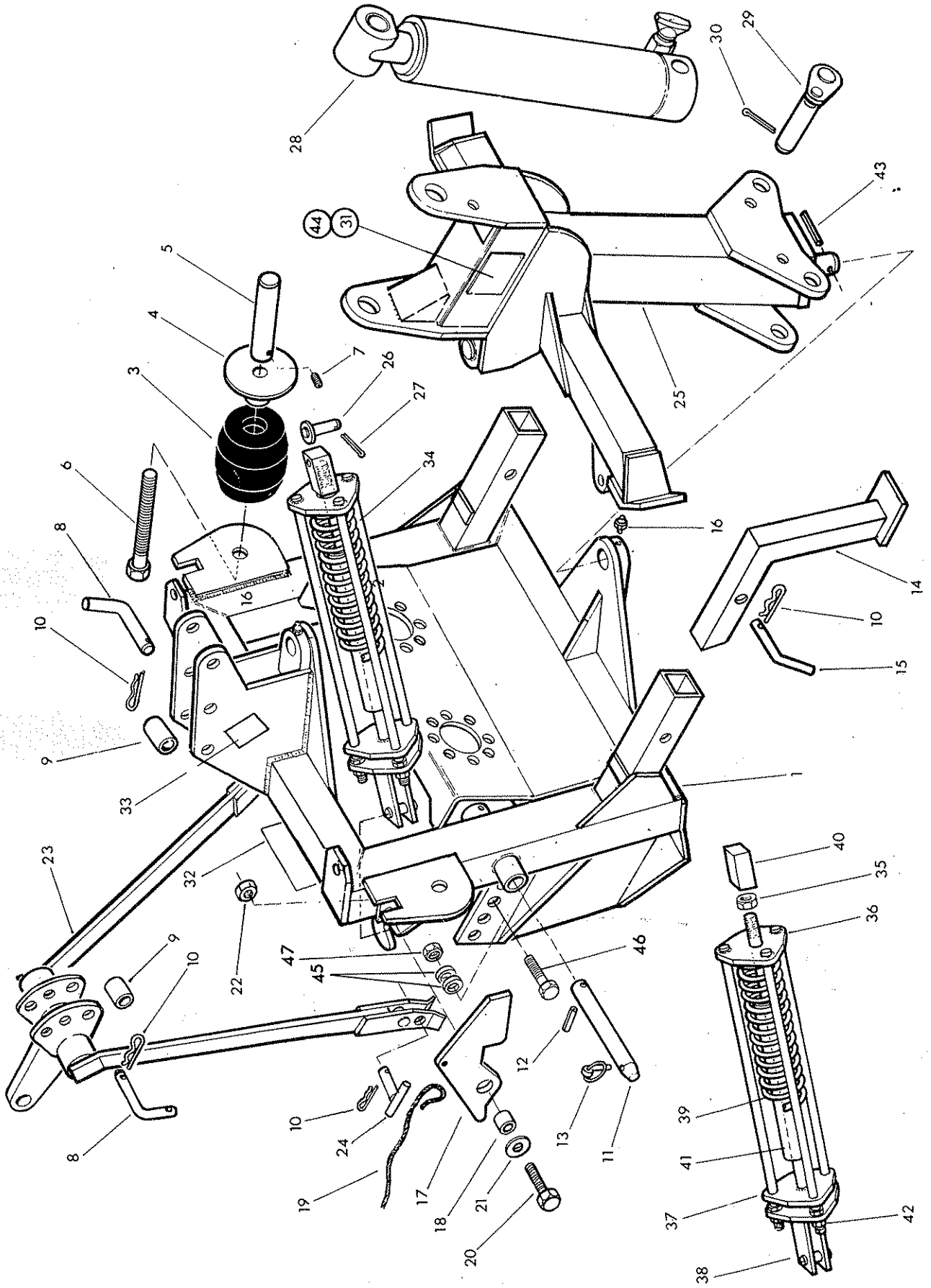



McCORMICK

Ref.	Part No.	Qty.	Description
MAIN FRAME, STABILISER & PILLAR			
1	71 93 391	1	Main frame
2	71 36 330	1	P.T.O. Shaft - not illustrated
3	71 35 033	1	Buffer
4	71 35 034	1	Buffer locating disc
5	71 93 323	1	Buffer abutment
6	71 35 293	1	Buffer bolt
7	93 63 034	1	Grubscrew
8	71 92 026	2	Top link pin
9	14 67 063	2	Sleeve
10	04 31 105	6	Spring cotter
11	71 93 020	2	Linkage pin
12	04 22 628	2	Spring dowel
13	04 31 217	2	Linch pin
14	71 92 307	2	Stand leg
15	71 92 023	2	Leg pin
16	09 01 121	2	Greaser
17	71 93 325	1	Latch
18	71 35 097	1	Spacer
19	71 35 036	1	Operating cord
20	92 13 106	1	Bolt
21	91 00 106	1	Plain washer
22	91 43 006	1	Self locking nut
23	71 92 405	1	Stabiliser
24	71 92 027	2	Stabiliser pin
25	71 93 356	1	Pillar
26	71 93 021	1	Anchor pin
27	95 01 406	1	Split pin
28	71 93 333	1	Lift ram assembly see page 57
29	71 93 025	1	Pin - Lift ram base
30	05 03 166	1	Split pin
31	13 35 246	1	Serial No. plate
32	71 35 295	1	Sticker - "Tighten check chains"
33	71 05 130	1	Sticker - "Read instruction book first"
34	71 35 314	1	Breakaway assistor spring assy. includes
35	01 11 006	1	Nut
36	71 35 315	1	Spring cage
37	71 35 316	1	Tie rod
38	71 35 317	1	Jaw end
39	71 35 298	1	Spring
40	71 35 081	1	Pinned end
41	71 35 318	1	Spacer
42	01 11 003	6	Nut
43	04 22 632	1	Spring Dowel
44	71 03 230	4	Pop rivet
45	71 92 080	4	Eccentric collar
46	92 13 148	2	Bolt
47	91 43 008	2	Self locking nut

MAIN ARM & ROCKER



McCOMEL

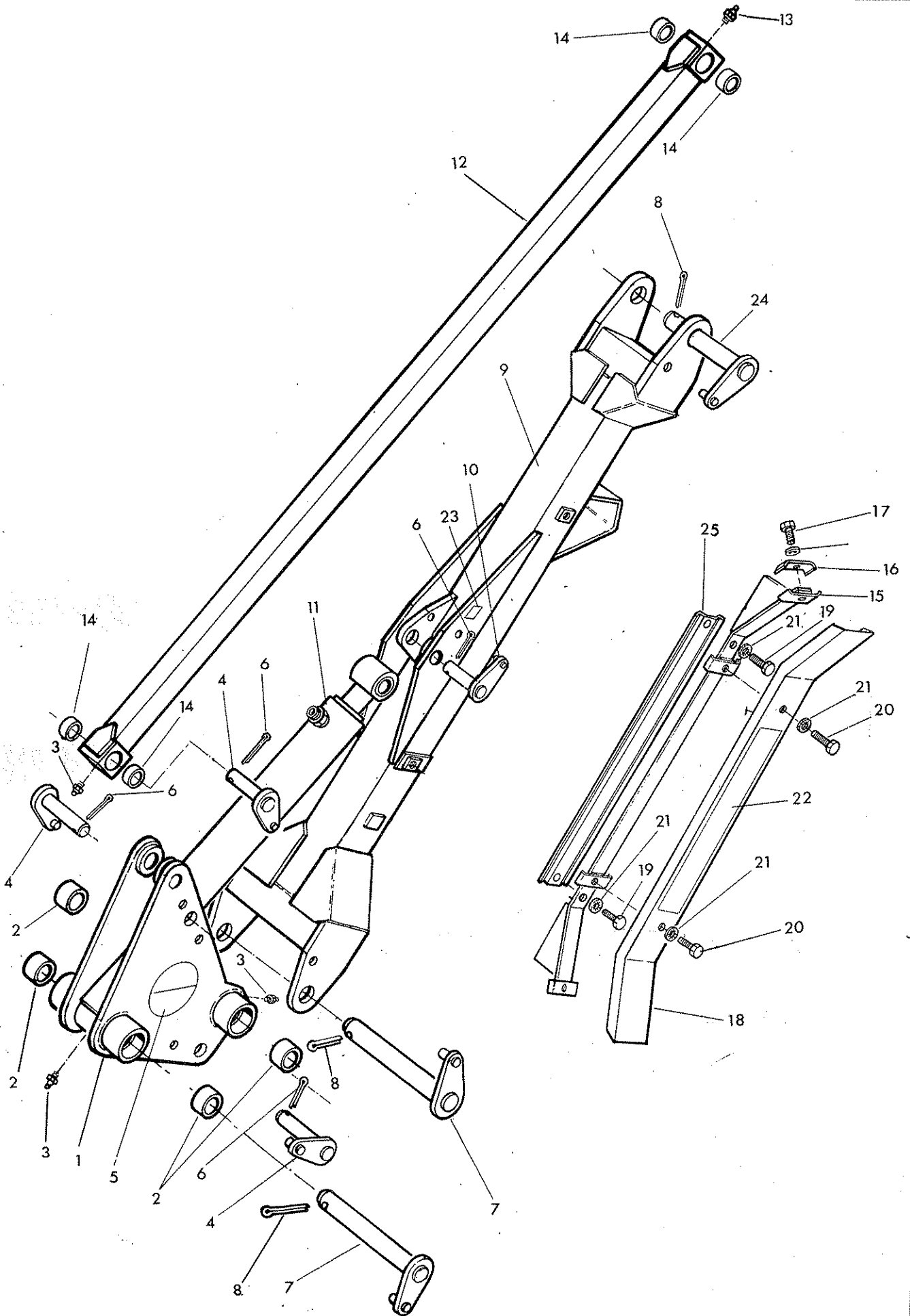



McCONNEL

Ref.	Part No.	Qty.	Description
MAIN ARM ROCKER & TENSION LINK FOR STD. POWER MACHINES			
1	71 93 330	1	Rocker
2	72 13 023	4	Bush - Rocker pivot
3	09 01 121	3	Greaser
4	71 93 025	4	Pivot pin - Tension link, Reach base & lift ram rod
5	12 90 296	1	Sticker "Logo roundel"
6	05 03 166	5	Split pin
7	71 93 033	2	Pivot pin - Main Arm and rocker
8	95 01 509	3	Split pin dia
9	71 93 355	1	Main arm
10	71 93 022	1	Pivot pin - Reach
11	71 93 334	1	Reach ram assembly - see page 59
12	71 93 326	1	Tension link
13	09 01 124	1	Greaser
14	60 12 032	4	Bush
15	71 93 312	1	Hose guide - Main Arm
16	71 93 014	2	Hose clamp
17	92 13 085	2	Bolt
18	71 93 320	1	Hose cover - Main Arm
19	93 13 055	2	Bolt
20	93 13 055	2	Setscrew
21	91 00 305	6	Internal serrated washer
22	12 90 255	1	Sticker "McConnel"
23	60 55 002	1	Sticker "Sling here"
24	71 93 034	1	Pivot pin - Dipper

MAIN ARM ROCKER & TENSION LINK FOR HIGH POWER MACHINES

The parts list is identical to above with the following exceptions

15	71 95 309	1	Hose guide main arm
16	71 93 015	2	Hose clamp
17	92 13 095	2	Bolt
19	92 13 095	2	Bolt
25	71 95 311	1	Hose plate

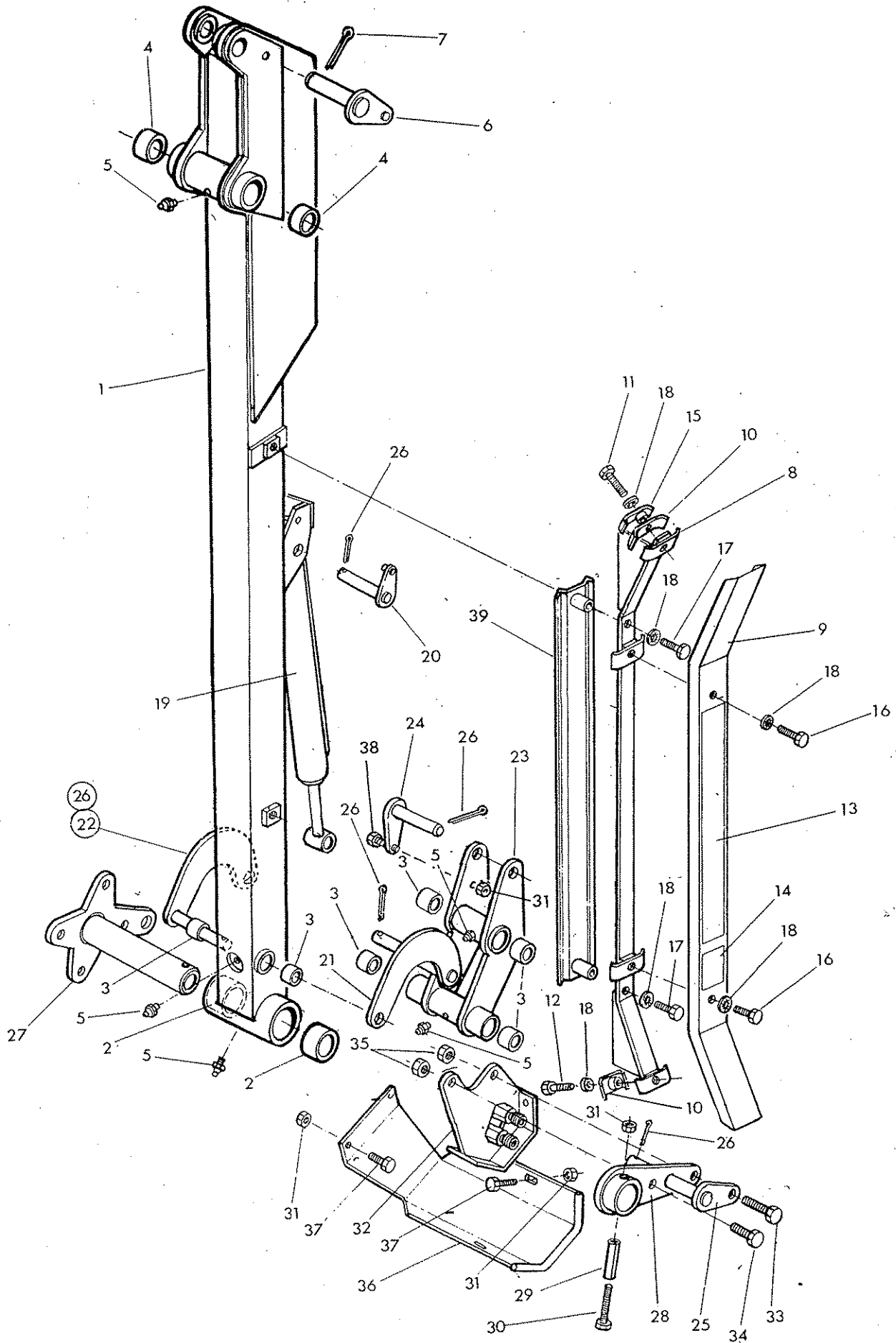
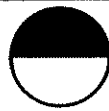

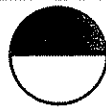

Ref.	Part No.	Qty.	Description
------	----------	------	-------------

**STANDARD DIPPER ARM AND ANGLING FOR
STANDARD POWER MACHINES**

1	71 93 308	1	Dipper arm
2	71 36 035	2	Bush - head pivot
3	41690-01	6	Bush - Radius arm pivot and slave link
4	72 13 023	2	Bush - Dipper pivot
5	09 01 121	4	Greaser
6	71 93 025	1	Pivot pin - Tension link
7	05 03 166	1	Split pin
8	71 93 313	1	Hose guide - dipper
9	71 93 321	1	Hose cover - dipper
10	71 93 014	2	Hose clamp
11	92 13 125	1	Bolt
12	92 13 085	1	Bolt
13	12 90 295	1	Sticker 'Power Arm'
14	12 90 292	1	Sticker '94'
15	71 93 019	1	Hose clip - angle
16	93 13 055	2	Bolt
17	93 15 055	2	Setscrew
18	91 00 305	6	Internal serrated washer dia 10
19	75 60 344	1	Angle ram assembly - (see page 50)
20	71 92 024	1	Pivot pin - Angle ram base
21	74 50 250	1	Radius arm - rear
22	74 50 251	1	Radius arm - front
23	71 92 309	1	Slave link
24	41693-01	1	Pivot pin - Angle ram rod
25	71 92 009	1	Pivot pin - Slave link
26	95 01 406	5	Split pin dia
27	71 92 308	1	Head pivot tube
28	71 92 316	1	Jaw plate
29	04 23 548	1	Spring dowel
30	92 13 185	1	Bolt
31	91 43 005	6	Self locking nut
32	71 92 321	1	Hose junction bracket
33	02 11 146	1	Bolt
34	02 11 126	1	Bolt
35	01 41 006	2	Self locking nut
36	71 92 324	1	Hose tray
37	93 13 045	4	Setscrew
38	93-15-055	2	Setscrew

**STD DIPPER ARM & ANGLING MECHANISM FOR
HI POWER MACHINES**

8	71 95 310	1	Hose guide
10	71 93 015	2	Hose clamp
12	92 13 095	1	Bolt
14	92 13 095	2	Bolt
32	71 95 303	1	Hose junction bracket
39	71 95 312	1	Hose plate

MID CUT DIPPER



McCOMEL

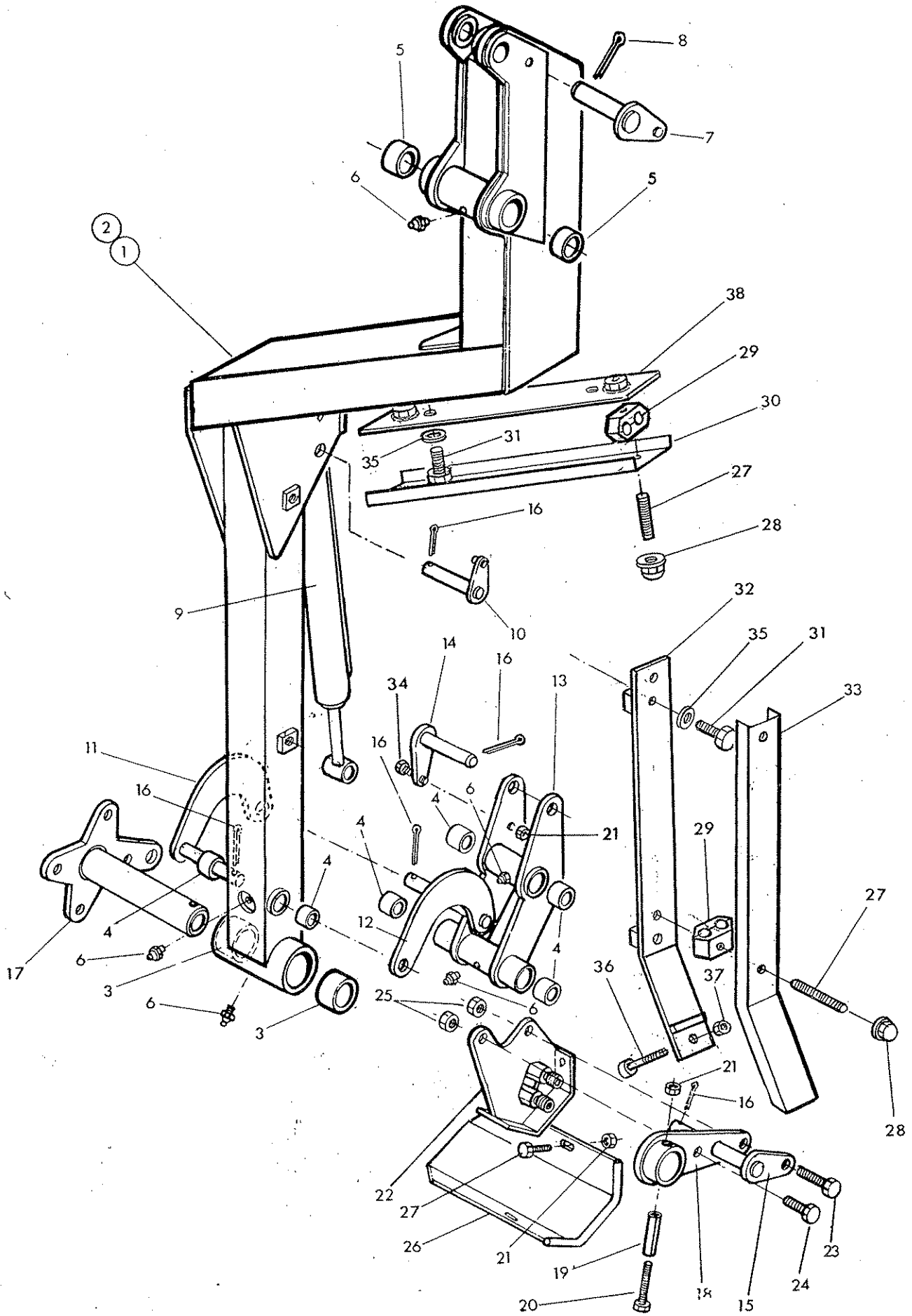



Ref	Part No	Qty	Description
MID CUT DIPPER ARMS AND ANGLING MECHANISM			
R HAND			
1	71 93 345		Dipper arm R Hand
L HAND			
2	71 93 346		Dipper arm L Hand
Items 3 to 38 inclusive are common to both mid cut dipper arm assemblies			
3	71 36 035	2	Bush - head pivot
4	41690.01	6	Bush - radius arm pivot and slave link
5	72 13 023	2	Bush - dipper pivot
6	09 01 121	5	Greaser
7	71 93 025	1	Pivot pin - tension link
8	05 03 166	1	Split pin
9	75 60 344	1	Angle ram assembly
10	71 92 024	1	Pivot pin - angle ram base
11	74 50 251	1	Radius arm - front
12	74 50 250	1	Radius arm - rear
13	71 92 309	1	Slave link
14	41693.01	1	Pivot pin - angle ram rod
15	71 92 009	1	Pivot pin - slave link
16	95 01 406	5	Split pin dia
17	71 92 308	1	Head pivot tube
18	71 92 316	1	Jaw plate
19	04 23 548	1	Spring dowel
20	92 13 185	1	Bolt
21	91 43 005	6	Self locking nut
22	71 95 303	1	Hose junction bracket - Hi power
	71 92 321	1	Hose junction bracket - Std power
23	02 11 146	1	Bolt
24	02 11 126	1	Bolt
25	01 41 006	2	Self locking nut
26	71 98 333	1	Hose tray
27	04.282.76	4	Stud
28	91 00 025	4	Dome nut
29	42024.06	5	Hose clamp - 1 pair - Hi power
	71 90 148	1	Hose clamp - 1 pair - Std power
30	71 93 047	1	Hose cover
31	93 13 045	6	Bolt
32	42951.01	1	Hose guide
33	71 93 048	1	Hose cover
34	93 13 055	1	Setscrew
35	91 00 305	4	Internal serrated washer
36	92 43 154	1	Capscrew
37	91 43 004	1	Self locking nut
38	42952.01	1	Hose guide

**CONTROL MOUNTING
ASSY**



MCCORMEL

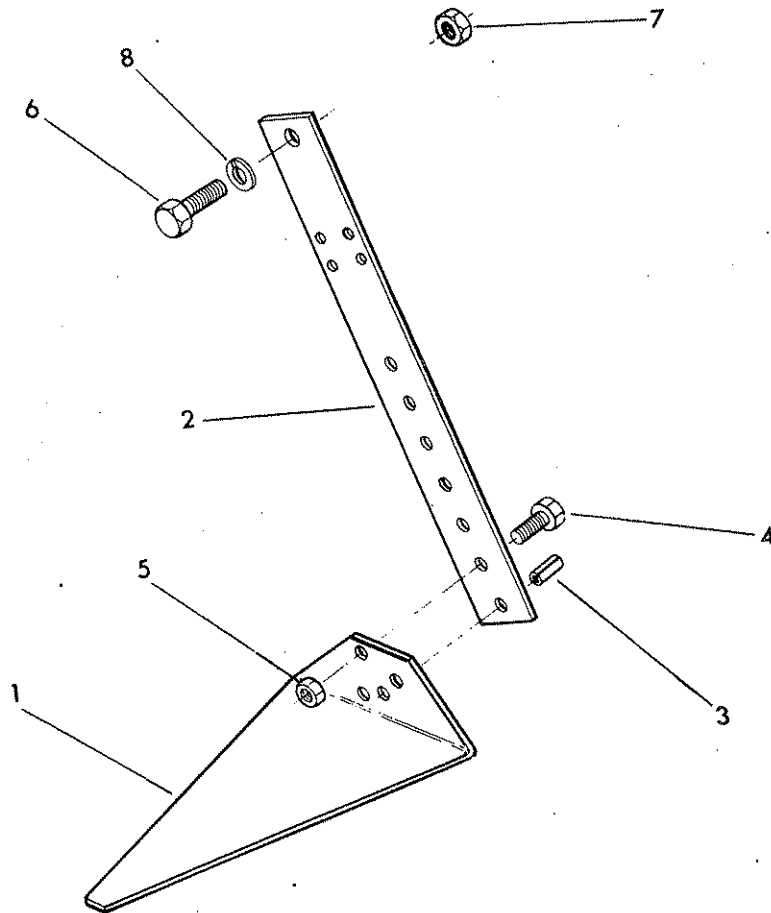

Ref.	Part No.	Qty.	Description
	71-90-319		CONTROL MOUNTING ASSEMBLY
1	71-09-320	1	Sandwich plate
2	71-09-146	1	Pillar including spring dowel
3	04-22-816	1	Spring dowel
4	93-13-066	1	Setscrew
5	91-13-006	1	Nut
6	93-11-086	1	Setscrew
7	01-11-006	1	Nut
8	01-00-206	1	Spring washer

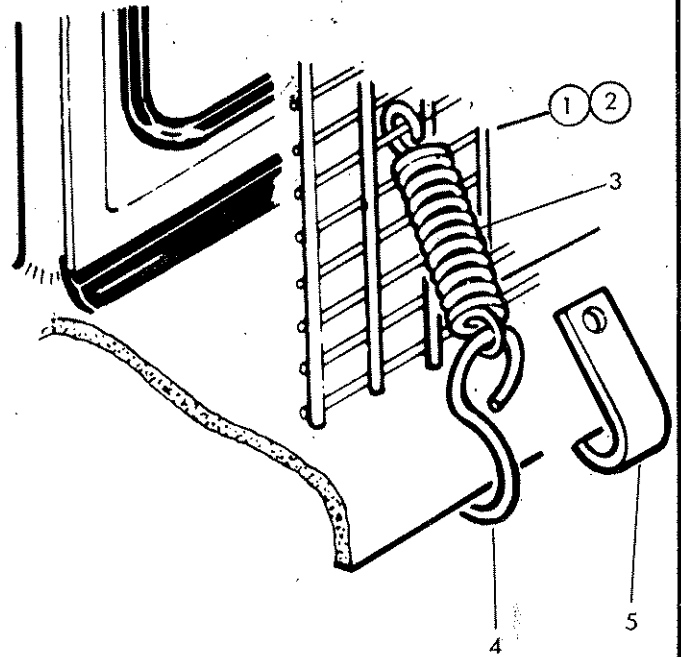
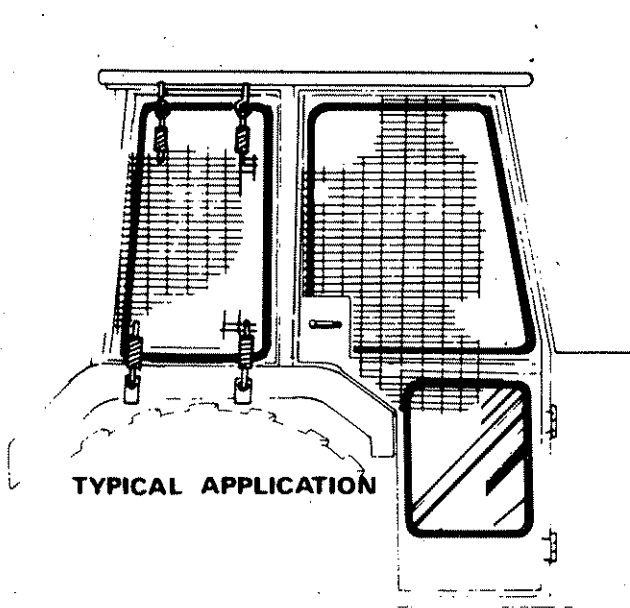

Ref.	Part No.	Qty.	Description
	73-13-324		CAB GUARD KIT
1	73-13-049	1	Guard panel - large
2	73-13-050	1	Guard panel - small
3	60-01-064	12	Spring
4	60-01-065	6	Hook
5	73-13-051	6	Hook

FLAIL HEAD CASING



McCONNEL

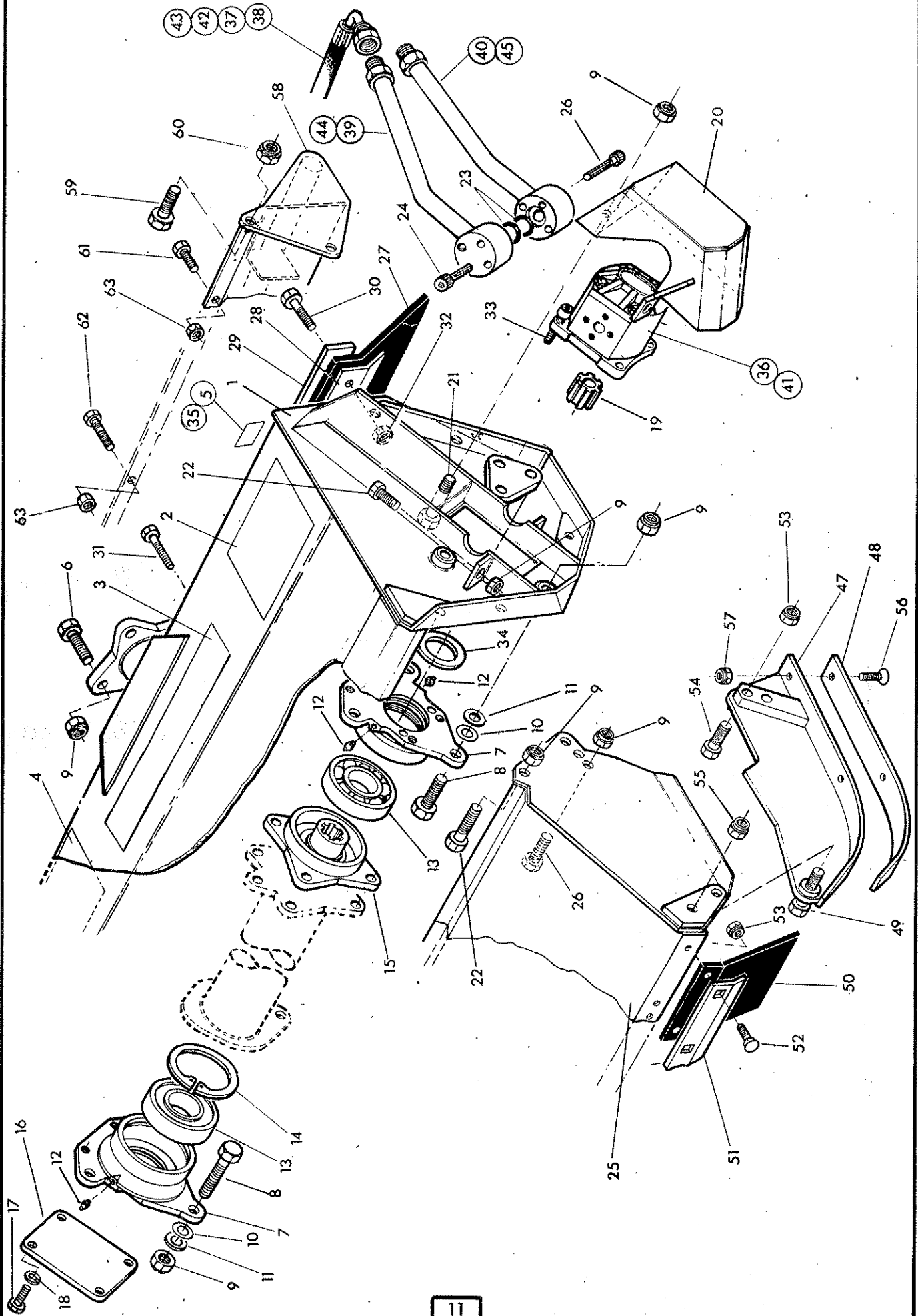



McCONNEL

Ref.	Part No.	Qty.	Description
FLAIL HEAD CASING			
1	71 90 262	1	Flail casing
2	12 90 377	1	Sticker 'Flail head instructions'
3	12 90 255	1	Sticker 'McConnel'
4	12 90 341	1	Sticker 'Flail guarding'
5	13 35 246	1	Serial No. plate
6	02 11 186	4	Bolt
7	71 90 261	2	Bearing housing
8	02 11 166	4	Bolt
9	01 41 006	17	Self locking nut
10	81 21 043	as reqd	Shim .015"
11	81 21 044	as reqd	Shim .025"
12	09 01 121	4	Greaser
13	06 00 018	2	Bearing
14	71 90 022	1	Internal circlip
15	71 90 472	1	Rotor hub
16	71 90 444	1	Cover plate
17	93 13 045	4	Setscrew
18	91 00 205	4	Spring washer
19	71 90 009	1	Drive coupling
20	71 90 488	1	Motor cover
21	02 11 266	1	Bolt
22	03 11 126	4	Setscrew
23	86 00 121	2	'O' ring
24	93 00 014	6	Capscrew 'wedglok'
25	71 90 288	1	Front hood
26	03 11 106	2	Setscrew
27	71 90 314	1	Rear flap
28	71 90 312	1	Mounting strip
29	71 90 313	1	Clamp strip
30	93 13 065	7	Setscrew
31	93 13 075	2	Setscrew
32	91 43 005	9	Self locking nut
33	93 00 144	4	Capscrew wedglok
34	71 90 015	1	Motor locating washer
35	71 03 230	4	Pop rivet

The following items 36-40 inclusive are also required for std power machines.

36*	83 01 281	1	Hydraulic motor
-----	-----------	---	-----------------

Continued overleaf

FLAIL HEAD CASING



McCONEL

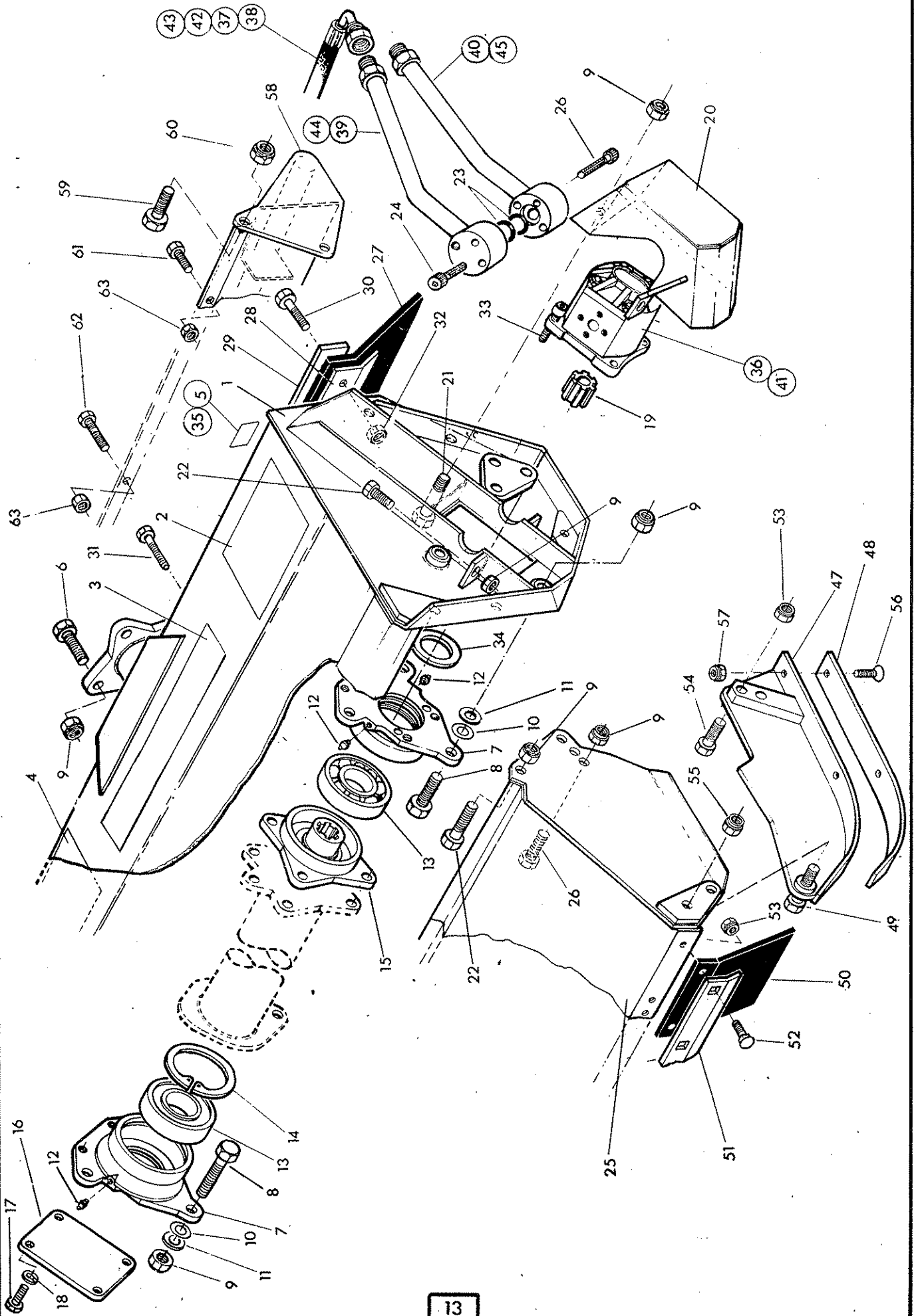



FLAIL HEAD CASING continued.

37	85 38 015	2	Hose 3/4" BSP x 34" long for heads with motor outboard
38	85 38 025	2	Hose 3/4" BSP x 42" long for heads with motor inboard
39	71 90 295	1	Motor pipe upper
40	71 90 296	1	Motor pipe lower

86 99 236

SEAL KIT - for hydraulic motor

The following items 41-45 inclusive are also required for Hi Power machines

41	83 01 282	1	Hydraulic motor
42	85 01 097	2	Hose 1" BSP x 34" long for heads with motor outboard
43	85 01 154	2	Hose 1" BSP x 42" long for heads with motor inboard
44	71 90 297	1	Motor pipe upper
45	71 90 298	1	Motor pipe lower

86 99 236

SEAL KIT- for hydraulic motor

EXTRA PARTS FOR GRASS CUTTING

46	71 90 300	1	Skid R. Hand - not illus
47	71 90 301	1	Skid L. Hand
48	73 14 323	2	Replaceable skid
49	03 11 146	2	Setscrew
50	71 90 020	8	Flap
51	71 90 304	1	Flap clamp strip
52	92 93 054	16	Cup square bolt
53	91 43 004	16	Self locking nut
54	03 11 086	2	Setscrew
55	01 41 006	4	Self locking nut
56	93 33 065	6	Setscrew c/sunk
57	91 43 005	6	Self locking nut

EXTRA PARTS FOR DOWNWARD CUTTING

	71 90 310	1	Rear hood kit
58	71 90 285	1	Rear hood
59	03 11 106	4	Bolt
60	01 41 006	4	Self locking nut
61	93 13 045	7	Setscrew
62	93 13 055	2	Setscrew
63	91 43 005	9	Self locking nut

ROTOR & FLAIL OPTIONS



McCORMICK

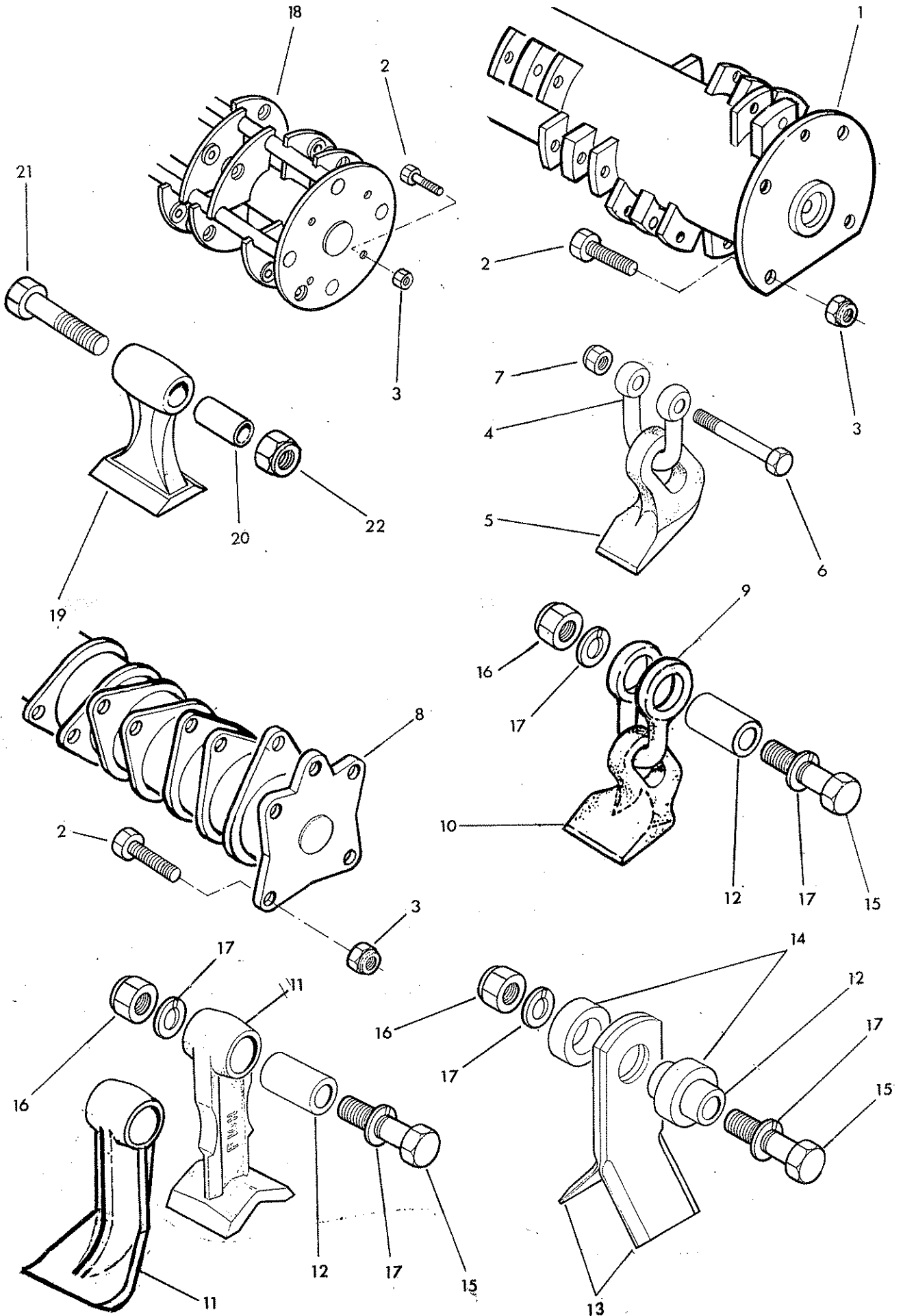



Ref Part No Qty Description

ROTORS AND FLAILS

140mm DIA ROTOR SUITABLE FOR HI POWER FLAIL HEADS ONLY

1	71 90 424	1	Rotor 1.2m (32 flail stations)
2	03 11 146	4	Setscrew 5/8 UNF x 1 3/4" long
3	01 41 006	4	Self locking nut 5/8 UNF

FLAIL FOR 140mm DIA ROTORS - Quantities shown are per flail station

4	71 90 086	1	Shackle
5	71 90 463	1	Flail
6	71 90 088	1	Special bolt
7	01 41 004	1	Self locking nut 7/16 UNF

100mm DIA ROTOR SUITABLE FOR STANDARD AND HI POWER FLAIL HEADS

8	71 90 320	1	Rotor (24 flail stations)
---	-----------	---	---------------------------

FLAIL OPTIONS FOR 100mm DIA ROTORS - Quantities show are per flail station.

9	71 90 106	1	Shackle
10	71 90 462	1	Flail
11	73 14 366	1	Flail F10H
	73 90 276	1	Flail - alternative single edged
12	73 14 223	1	Pivot bush
13	71 90 315	2	Flail
14	71 90 010	2	Flail spacer
15	73 14 201	1	Special bolt
16	01 41 006	1	Self locking nut 5/8 UNF
17	01 00 206	2	Spring washer 5/8" dia

OMEGA ROTOR SUITABLE FOR 1.2 METRE FLAIL HEADS

18	71 90 465	1	Rotor (20 flail stations)
----	-----------	---	---------------------------

FLAIL FOR OMEGA ROTOR - Quantities are per flail station

19	71 90 464	1	Flail
20	71 90 117	1	Bush
21	71 90 118	1	Special bolt
22	01 41 006	1	Self locking nut 5/8" UNF

**McCORMICK**

Ref.	Part No.	Qty.	Description
ROLLERS OPTIONS FOR 1.2m FLAIL HEADS			
BUSHED ROLLER ASSEMBLY			
1	71 90 306	1	Roller bracket L. Hand
2	71 90 305	1	Roller bracket R. Hand - not illus
3	02 11 166	2	Bolt
4	81 21 043	as reqd	Shim
5	81 21 044	as reqd.	Shim
6	71 90 032	2	Pin
7	04 31 213	2	Linch pin
8	71 90 307	1	Roller
9	71 90 308	1	Roller tie rod
10	72 13 023	2	Bush
11	71 90 026	2	Thrust washer
12	71 90 028	2	Felt seal
13	09 01 121	2	Greaser
14	71 90 023	2	Tab washer
15	71 14 176	2	Special nut
16	01 41 006	4	Self locking nut
BALL BEARING ROLLER ASSEMBLY			
17	71 90 434	1	Roller
18	71 90 429	2	Roller end
19	71 90 428	2	Mounting bracket
20	02 11 206	4	Bolt
21	01 41 006	4	Self locking nut
22	02 11 123	2	Bolt
23	01 00 203	2	Spring washer
24	04 25 408	2	Spring dowel
25	71 90 430	2	Stub axle
26	09 01 121	2	Greaser
27	86 00 139	2	'O' ring
28	04 11 262	2	Internal circlip
29	04 01 225	2	External circlip
30	06 00 088	4	Bearing
31	71 90 082	2	Spacer
32	86 29 125	2	Seal
33	04 12 120	2	Spring ring
34	93 00 104	6	Capscrew - self locking



Std.arm T.I. 1

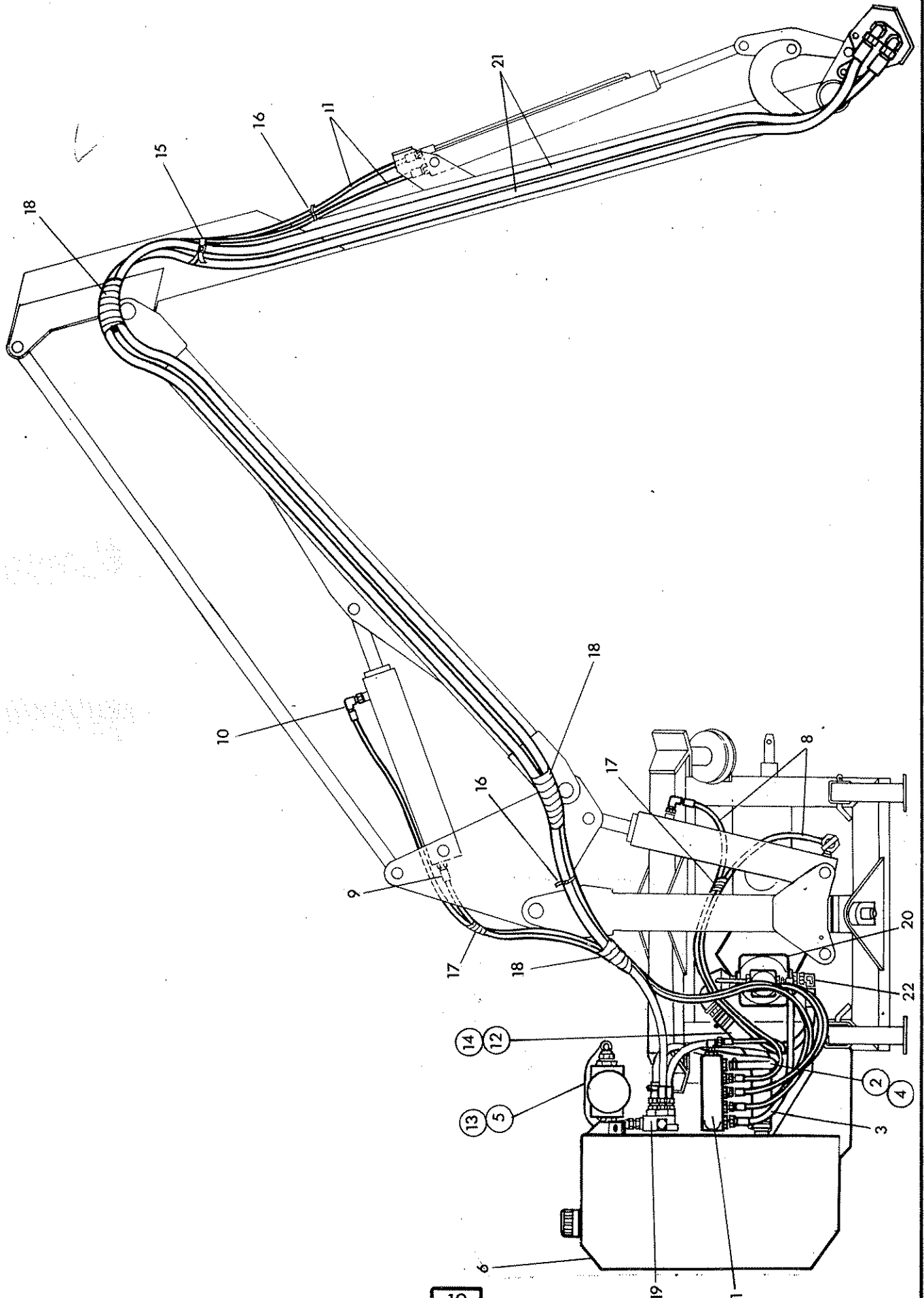



Ref.	Part No.	Qty.	Description.
------	----------	------	--------------

HYDRAULIC INSTALLATIONS FOR STANDARD ARM T.I. MACHINES

Items 1 to 17 inclusive are common to all standard arm T.I. hydraulic installations

1	81 30 372	1	Control valve assembly (see pages 35 - 38)
2	85 01 158	1	Hose 5/8" bore x 24" long. Return to rotor on/off valve
3	85 11 253	1	Hose 3/8" BSP x 18" long. Supply from pump
4	09 04 204	2	Hose clip - 5/8 bore hose
5	85 00 836	1	Hose low pressure 1" bore x 36" long rotor valve-tank
6		1	Tank assembly (see page 53)
7	71 09 319	1	Control mounting assembly -not illus-(see page 9)
8	85 35 022	2	Hose 1/4 BSP x 48" long. Lift
9	85 15 132	1	Hose 1/4" BSPF x 64" long. Reach base
10	85 35 142	1	Hose 1/4" BSP S x 80" long. Reach gland
11	85 15 122	2	Hose 1/4" BSP x 162" long- Angle
12	85 01 122	1	Hose 1 1/2" bore x 11 3/4" long. Suction from tank
13	09 04 106	4	Hose clip
14	09 04 107	4	Hose clip
15	71 06 187	2	Hose tie
16	71 35 084	2	Hose tie
17	72 13 005	2	Hose armour coil

See over to continue



Std.arm T.I. 2

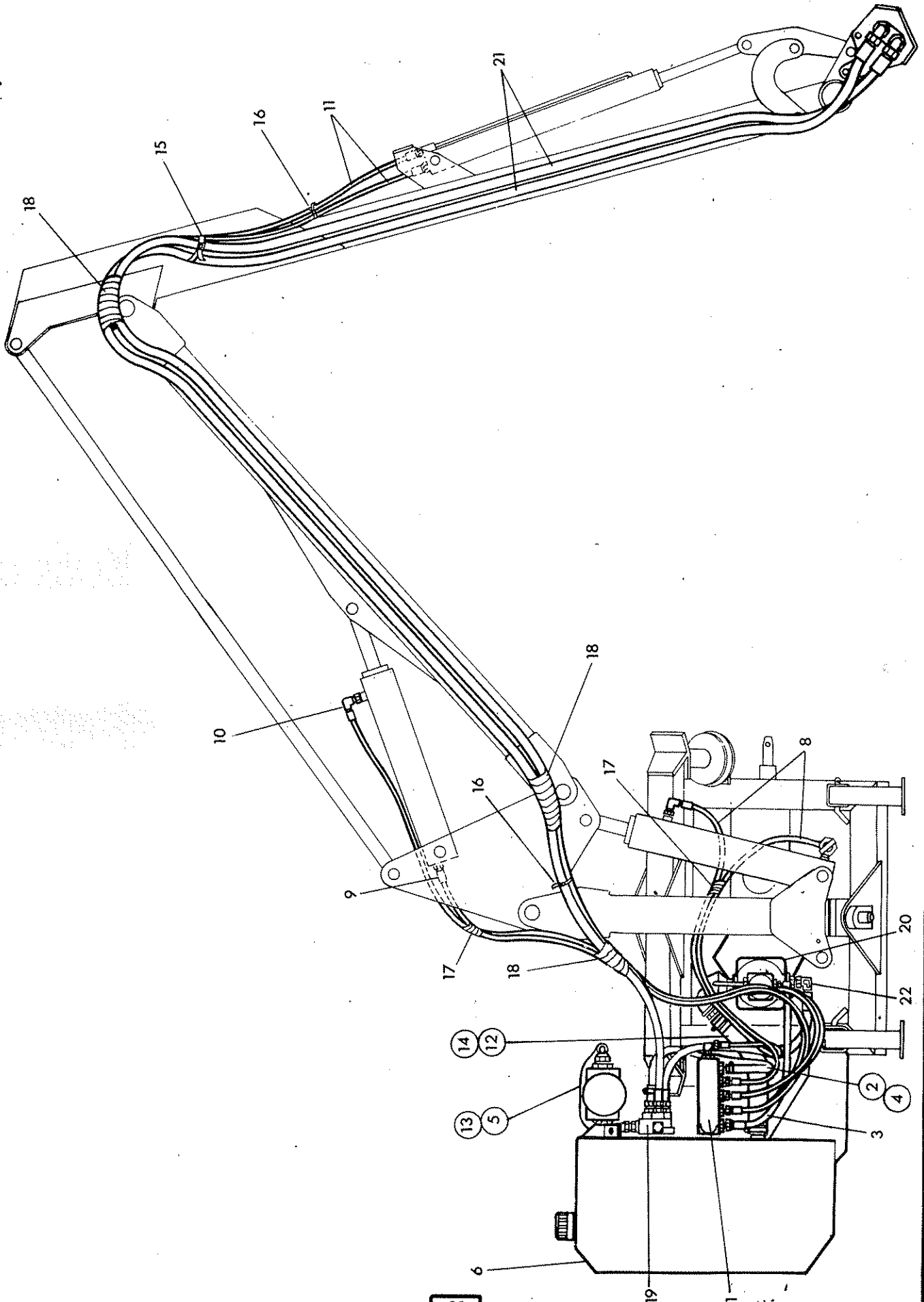



Ref.	Part No.	Qty.	Description
------	----------	------	-------------

HYDRAULIC INSTALLATIONS FOR STANDARD ARM T.I. MACHINES - Continued

The following additional items will be required for specific hydraulic installations.

HYDRAULIC INSTALLATION FOR R. HAND STD POWER. STD ARM T.I. MACHINES

18	71 93 026	3	Hose armour coil
19	81 25 377	1	Rotor Control valve assembly (see page 49)
20	80 13 459	1	Gearbox/pump assembly (See page 39)
21	85 38 065	2	Hose 3/4" BSP SF x 200" long-flail motor
22	85 38 045	1	Hose 3/4" BSP x 29" long-Pump- R.C. Valve

HYDRAULIC INSTALLATION FOR L.HAND STD POWER STD ARM T.I. MACHINES

18	71 93 026	3	Hose armour coil
19	81 25 378	1	Rotor control valve assembly (see page 49)
20	80 13 458	1	Gearbox/pump assemblies (see page 39)
21	85 38 065	2	Hose 3/4" BSP x 200" long-Flail motor
22	85 38 075	1	Hose 3/4" BSP x 20" long Pump- R.C. Valve

HYDRAULIC INSTALLATION FOR R. HAND HI POWER STD ARM T.I. MACHINES

18	71 36 143	3	Hose armour coil
19	81 25 379	1	Rotor control valve assembly (see page 49)
20	80 13 472	1	Gearbox/pump assembly (see page 41)
21	85 01 183	2	Hose 1" BSP x 200" long-Flail motor
22	85 01 169	1	Hose 1" BSP x 29" long Pump R.C. Valve

HYDRAULIC INSTALLATION FOR L. HAND HI POWER STD ARM T.I. MACHINES

18	71 36 143	3	Hose armour coil
19	81 25 380	1	Rotor control valve assembly (see page 49)
20	80 13 471	1	Gearbox/pump assembly (see page 41)
21	85 01 183	2	Hose 1" BSP x 200" long-Flail motor
22	85 01 201	1	Hose 1" BSP x 17" long Pump- R.C. Valve



Std. arm S.I. 1

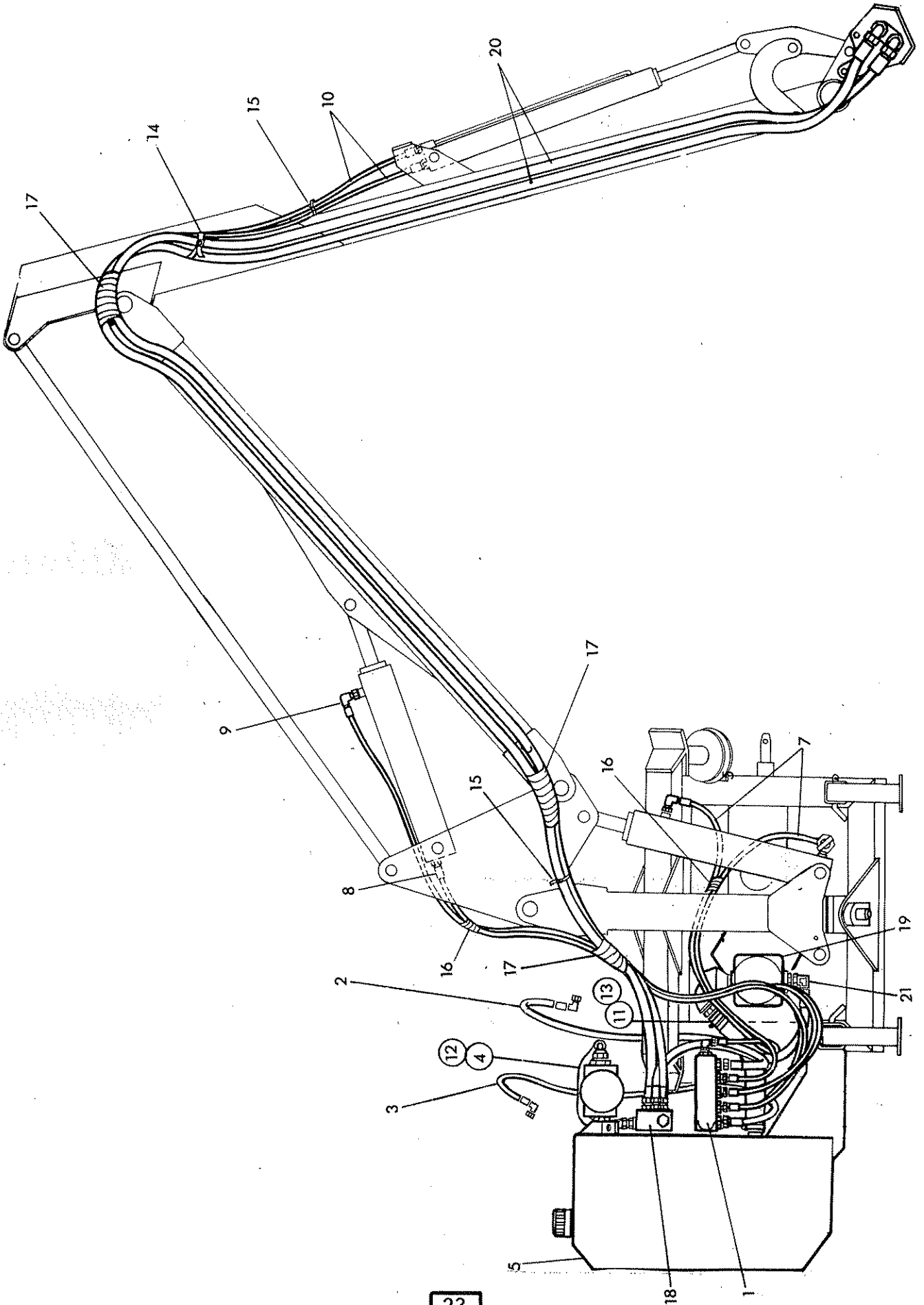



Ref.	Part No.	Qty.	Description
------	----------	------	-------------

HYDRAULIC INSTALLATIONS FOR STANDARD ARM S.I. MACHINES

Items 1 to 16 inclusive are common to all standard arm S.I. hydraulic installation

1	81 30 372	1	Control valve assembly (see pages 35-38)
2	85 32 014	1	Hose 1/2" BSP x 80" long Return tractor
3	85 31 323	1	Hose 3/8" BSP x 80" long-Supply
4	85 00 836	1	Hose low pressure 1" bore x 36" long rotor valve-tank
5		1	Tank assembly (see page 53)
6	71 09 319	1	Control mounting assembly -not illus- (see page 9)
7	85 35 022	2	Hose 1/4" BSP x 48" long. Lift
8	85 15 132	1	Hose 1/4" BSP x 64" long. Reach base
9	85 35 142	1	Hose 1/4" BSP x 80" long.Reach gland
10	85 15 122	2	Hose 1/4" BSP x 162" long-Angle
11	85 01 122	1	Hose 1 1/2" bore x 11 3/4" long.Suction from tank
12	09 04 106	4	Hose clip
13	09 04 107	4	Hose clip
14	71 06 187	2	Hose tie
15	71 35 084	2	Hose tie
16	72 13 005	2	Hose armour coil

See over to continue

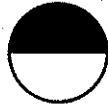

Std. arm S.I. 2

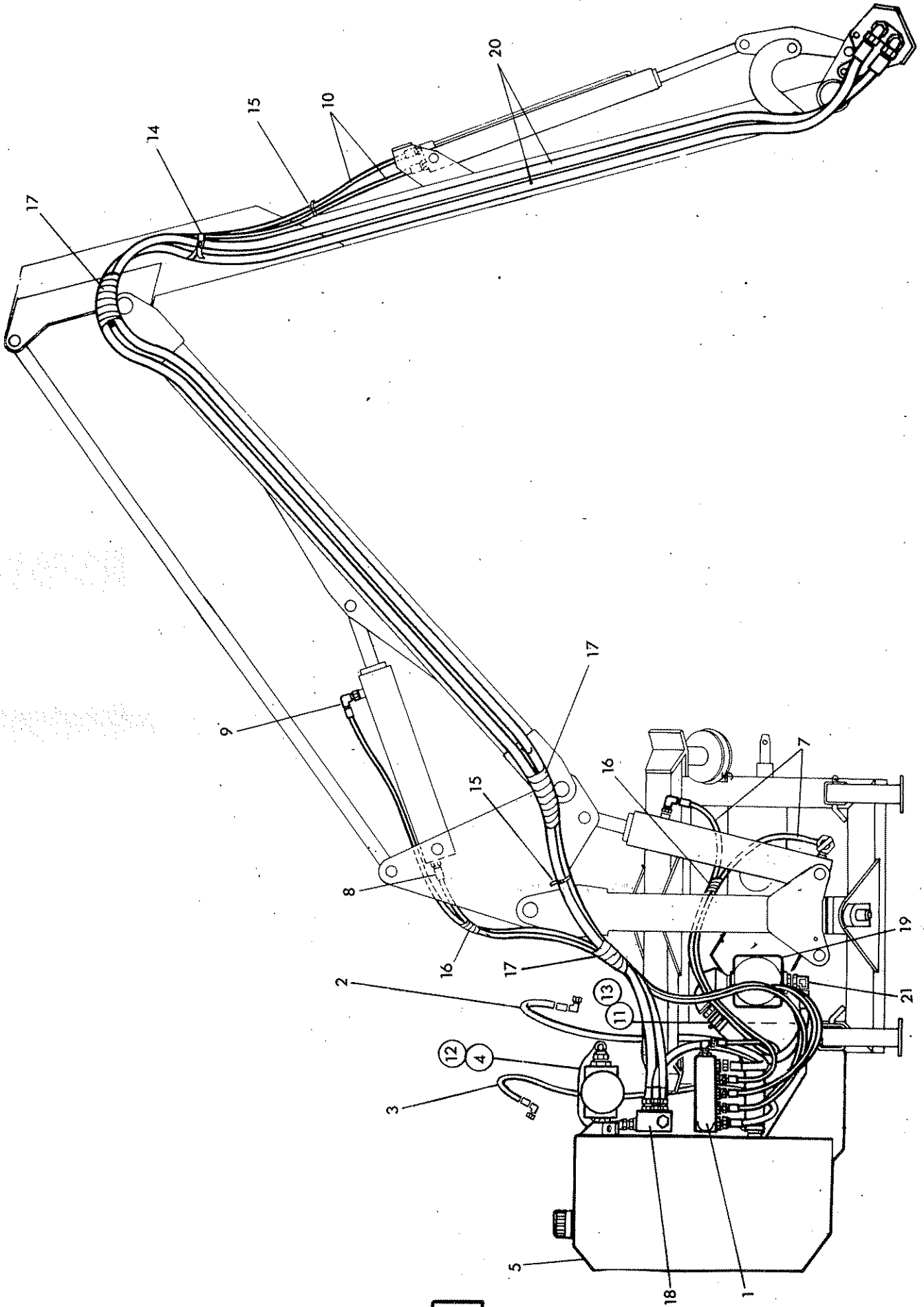



Ref	Part No.	Qty.	Description
-----	----------	------	-------------

HYDRAULIC INSTALLATION FOR STANDARD ARM S.I. MACHINES - continued

The following additional items will be required for specific hydraulic installations

HYDRAULIC INSTALLATION FOR R. HAND STD POWER. STD ARM S.I. MACHINES

17	71 93 026	3	Hose armour coil
18	81 25 360	1	Rotor relief valve assembly (see page 51)
19	80 13 457	1	Gearbox/pump assembly (See page 43)
20	85 38 065	2	Hose 3/4" BSP x 200" long-flail motor
21	85 38 045	1	Hose 3/4" BSP x 29" long-Pump- R.C. Valve

HYDRAULIC INSTALLATION FOR L. HAND STD POWER. STD ARM S.I. MACHINES

17	71 93 026	3	Hose armour coil
18	81 25 360	1	Rotor relief valve assembly (see page 51)
19	80 13 456	1	Gearbox / pump assembly (see page 43)
20	85 38 065	2	Hose 3/4" BSP x 200"long-Flail motor
21	85 38 075	1	Hose 3/4" BSP x 20"long Pump-R.C.Valve

HYDRAULIC INSTALLATION FOR R.HAND HI POWER. STD ARM S.I. MACHINES

17	71 36 143	3	Hose armour coil
18	81 25 400	1	Rotor Relief valve assembly (see page 51)
19	80 13 470	1	Gearbox/pump assembly (see page 45)
20	85 01 183	2	Hose 1" BSP x 200"long Flail motor
21	85 01 169	1	Hose 1" BSP x 29"long Pump- R.C. Valve

HYDRAULIC INSTALLATION FOR L. HAND HI POWER. STD ARM S.I. MACHINES

17	71 36 143	3	Hose armour coil
18	81 25 400	1	Rotor Relief valve assembly (see page 51)
19	80 13 469	1	Gearbox/pump assembly (see page 45)
20	85 01 183	2	Hose 1" BSP SF x 200" long-Flail motor
21	85 01 201	1	Hose 1" BSP x 17" long Pump R.C. Valve



Mid cut arm T.I. 1

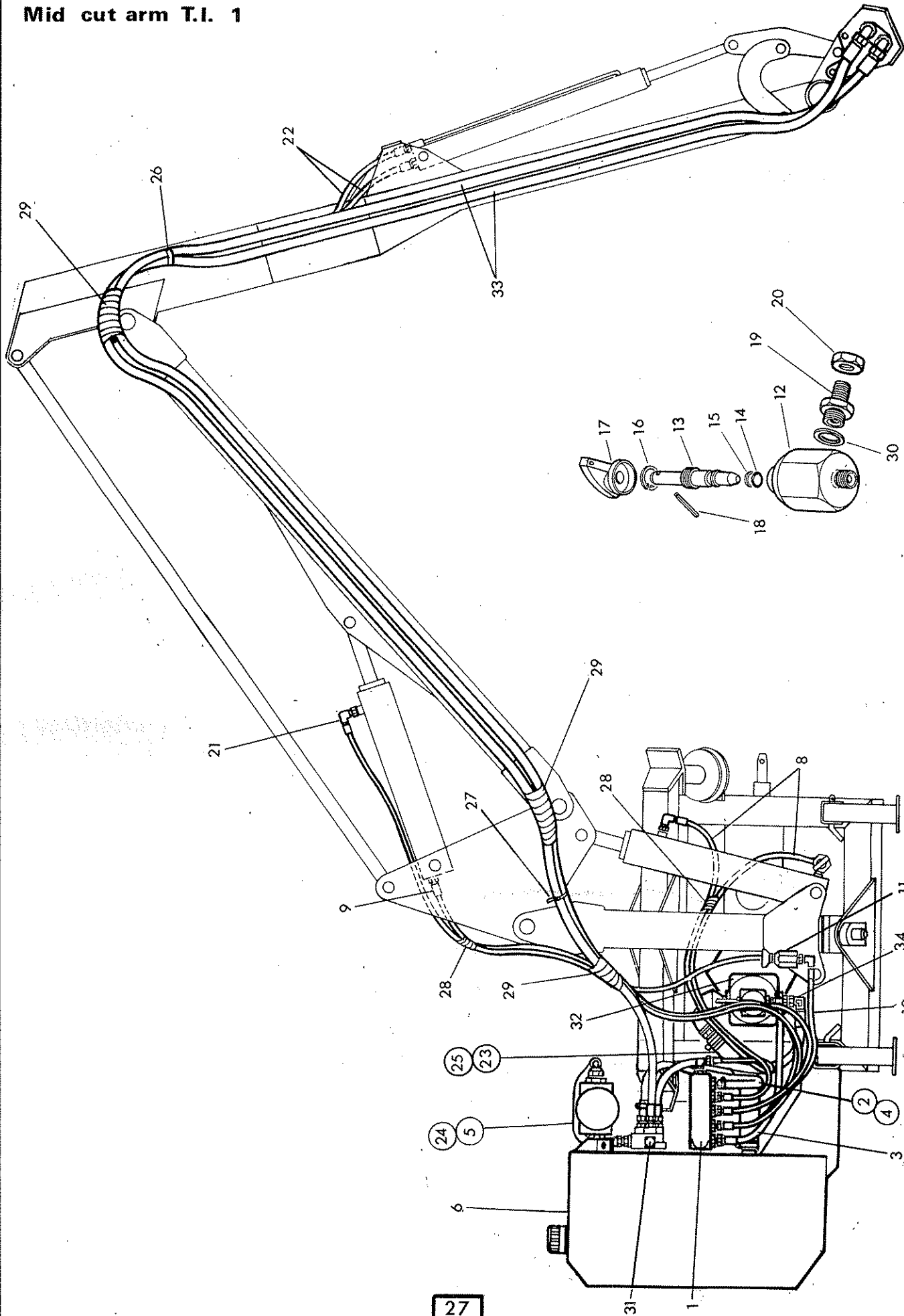



Ref.	Part No.	Qty.	Description.
------	----------	------	--------------

HYDRAULIC INSTALLATIONS FOR MID CUT ARM T.I. MACHINES

Items 1 to 29 inclusive are common to all mid cut arm T.I. hydraulic installations

1	81 30 372	1	Control valve assembly (see pages 35-38)
2	85 01 158	1	Hose 5/8" bore x 24" long. Return to rotor on/off valve
3	85 11 253	1	Hose 3/8" BSP x 18" long. Supply from pump
4	09 04 204	2	Hose clip - 5/8 bore hose
5	85 00 836	1	Hose low pressure 1" bore x 36" long rotor valve-tank
6		1	Tank assembly (see page 53)
7	71 09 319	1	Control mounting assembly -not illus-(see page 9)
8	85 35 022	2	Hose 1/4 BSP x 48" long. Lift
9	85 32 192	1	Hose 1/4" BSP x 44" long Reach base - tap
10	85 35 102	1	Hose 1/4" BSP x 17" long Reach tap - valve.
11	71 35 005	1	Lock tap assembly compr :-
12	71 35 284	1	Tap body
13	71 35 006	1	Tap spindle
14	86 00 107	1	O ring
15	86 09 107	1	Anti extrusion ring
16	04 16 110	1	Internal circlip
17	81 08 006	1	Tap knob
18	04 20 820	1	Spring dowel
19	85 81 297	1	Bulkhead adaptor
20	01 39 001	1	Backnut
21	85 35 142	1	Hose 1/4" BSP x 80" long. Reach gland
22	85 15 212	2	Hose 1/4" BSP x 185" long- Angle
23	85 01 122	1	Hose 1 1/2" bore x 11 3/4" long. Suction from tank
24	09 04 106	4	Hose clip
25	09 04 107	4	Hose clip
26	71 06 187	2	Hose tie
27	71 35 084	2	Hose tie
28	72 13 005	2	Hose armour coil
29	86 50 103	1	Bonded seal

See over to continue



Mid cut arm T.I. 2

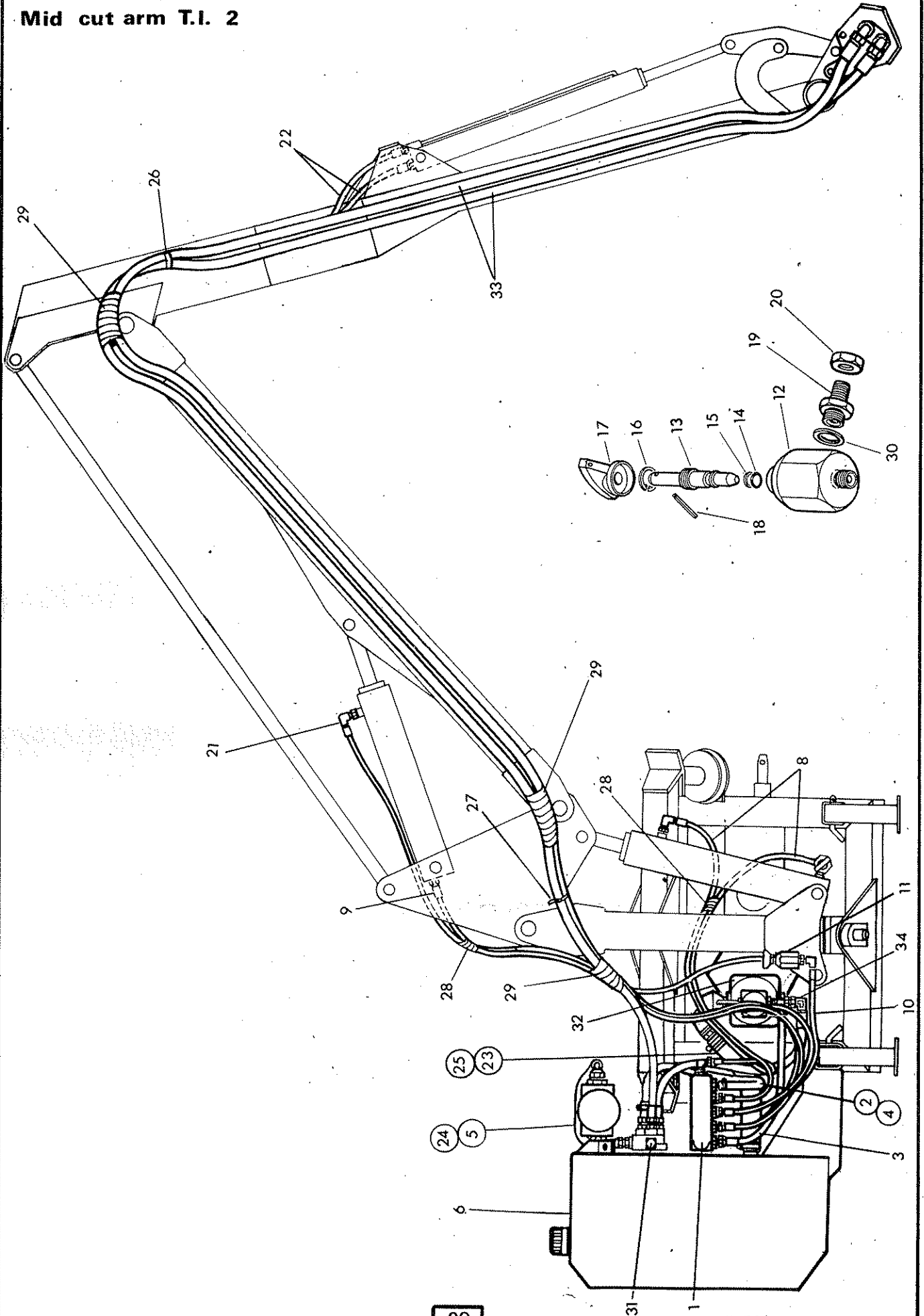



Ref	Part No.	Qty.	Description.
-----	----------	------	--------------

HYDRAULIC INSTALLATIONS FOR MID CUT ARM T.I. MACHINES - Continued

The following additional items will be required for specific hydraulic installations

HYDRAULIC INSTALLATION FOR R. HAND STD POWER MACHINES

30	71 93 026	3	Hose armour coil
31	81 25 377	1	Rotor Control valve assembly (see page 49
32	80 13 459	1	Gearbox/pump assembly (See page 39)
33	85 01 132	2	Hose 3/4" BSP x 212" long-flail motor
34	85 38 045	1	Hose 3/4" BSP x 29" long-Pump- R.C. Valve

HYDRAULIC INSTALLATION FOR L.HAND STD POWER MACHINES

30	71 93 026	3	Hose armour coil
31	81 25 378	1	Rotor control valve assembly (see page 49)
32	80 13 458	1	Gearbox/pump assemblies (see page 39)
33	85 01 132	2	Hose 3/4" BSP x 212" long-Flail motor
34	85 38 075	1	Hose 3/4" BSP x 20" long Pump- R.C. Valve

HYDRAULIC INSTALLATION FOR R. HAND HI POWER MACHINE

30	71 36 143	3	Hose armour coil
31	81 25 379	1	Rotor control valve assembly (see page 49)
32	80 13 472	1	Gearbox/pump assembly (see page 41)
33	85 01 205	2	Hose 1" BSP x 212" long-Flail motor
34	85 01 169	1	Hose 1" BSPx 29" long Pump R.C. Valve

HYDRAULIC INSTALLATION FOR L. HAND HI POWER MACHINES

30	71 36 143	3	Hose armour coil
31	81 25 380	1	Rotor control valve assembly (see page 49)
32	80 13 471	1	Gearbox/pump assembly (see page 41)
33	85 01 205	2	Hose 1" BSP x 212" long-Flail motor
34	85 01 201	1	Hose 1" BSP x 17" long Pump- R.C. Valve

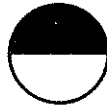

Mid cut arm S.I. 1

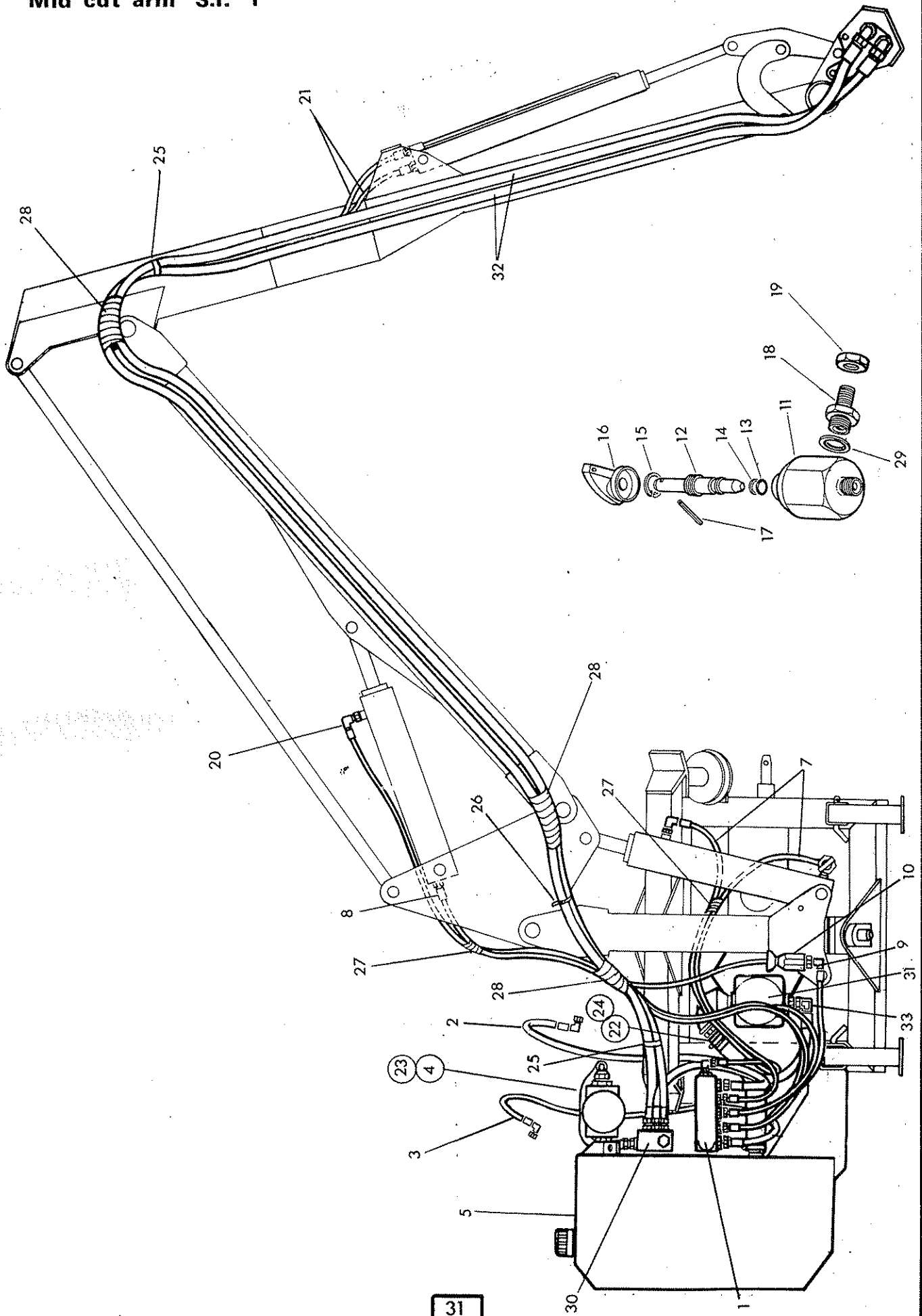



Ref.	Part No.	Qty.	Description
------	----------	------	-------------

HYDRAULIC INSTALLATIONS FOR MID CUT ARM S.I. MACHINES

Items 1 to 28 inclusive are common to all mid cut arm S.I. hydraulic installations

1	81 30 372	1	Control valve assembly (see pages 35-38)
2	85 32 014	1	Hose 1/2" BSP x 80" long Return tractor
3	85 31 323	1	Hose 3/8" BSP x 80" long-Supply
4	85 00 836	1	Hose low pressure 1" bore x 36" long rotor valve-tank
5		1	Tank assembly (see page 53)
6	71 09 319	1	Control mounting assembly -not illus- (see page 9)
7	85 35 022	2	Hose 1/4" BSP x 48" long. Lift SF - 90F
8	85 35 192	1	Hose 1/4" BSP x 44" long. Reach base- tap
9	85 35 102	1	Hose 1/4" BSP x 17" long. Reach tap - valve
10	71 93 050	1	Lock tap assembly compr :-
11	71 35 284	1	Tap body
12	71 35 006	1	Tap spindle
13	86 00 107	1	O ring
14	86 09 107	1	Anti extrusion ring
15	04 16 110	1	Internal circlip
16	81 08 006	1	Tap knob
17	04 20 820	1	Spring dowel
18	85 81 287	1	Bulkhead adaptor
19	01 39 001	1	Backnut
20	85 35 142	1	Hose 1/4" BSP x 80" long.Reach gland
21	85 15 212	2	Hose 1/4" BSP x 185" long-Angle
22	85 01 122	1	Hose 1 1/2" bore x 11 3/4" long.Suction from tank
23	09 04 106	4	Hose clip
24	09-04 107	4	Hose clip
25	71 06 187	2	Hose tie
26	71 35 084	2	Hose tie
27	72 13 005	2	Hose armour coil
28	86 50 103	1	Bonded seal

See over to continue

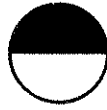

Mid cut arm S.I. 2

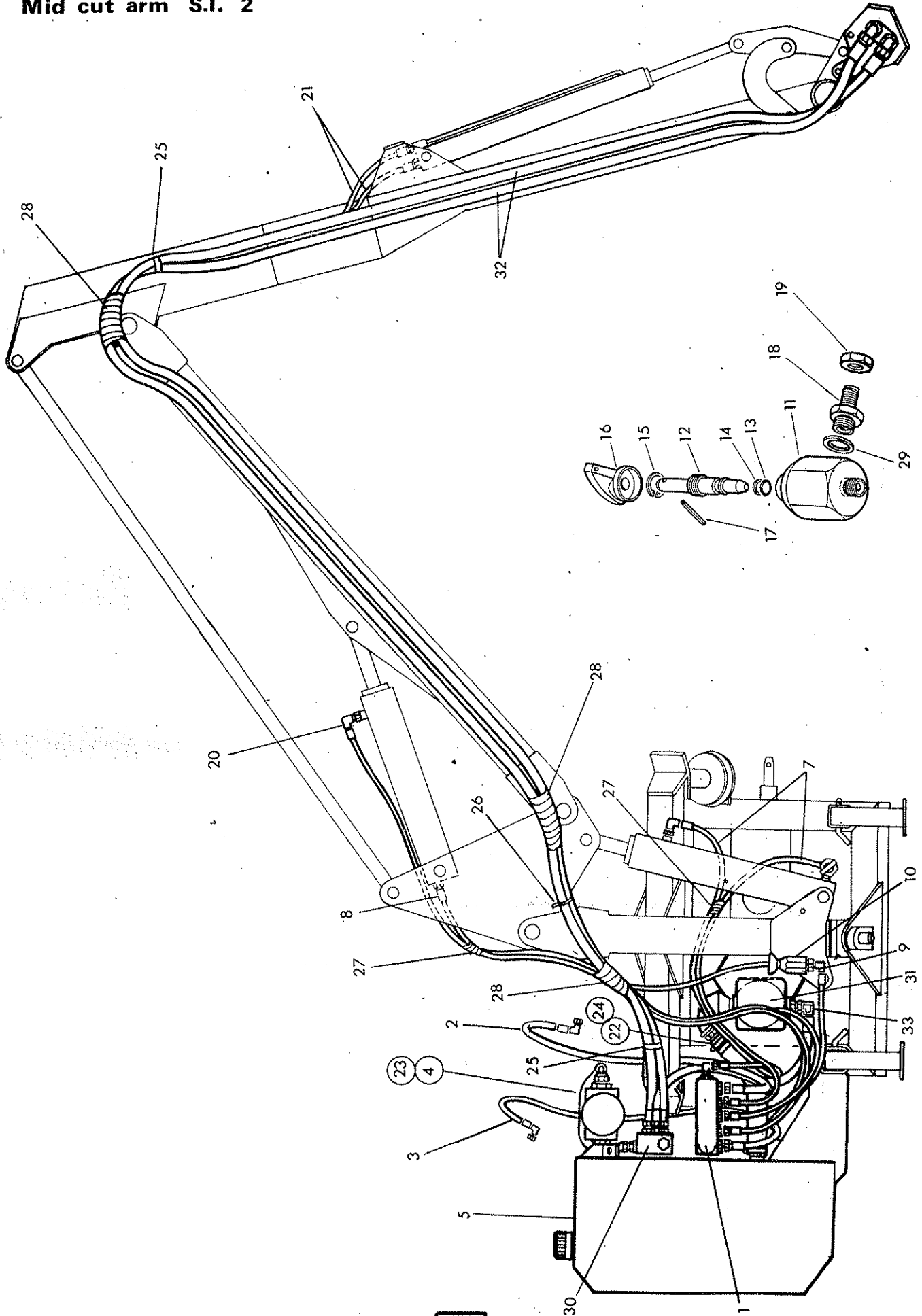



Ref.	Part No.	Qty.	Description
------	----------	------	-------------

HYDRAULIC INSTALLATION FOR MID CUT ARM SI. MACHINES - CONTINUED.

The following additional items will be required for specific hydraulic installations

HYDRAULIC INSTALLATION FOR R. HAND STD POWER MACHINES

29	91 93 026	3	Hose armour coil
30	81 25 360	1	Rotor relief valve assembly (see page 51)
31	80 13 457	1	Gearbox/pump assembly (See page 43)
32	85 01 132	2	Hose 3/4" BSP SF - 90F x 212" long-flail motor
33	85 38 045	1	Hose 3/4" BSP x 29" long-Pump- R.C. Valve

HYDRAULIC INSTALLATION FOR L. HAND STD POWER. MACHINE

29	71 93 026	3	Hose armour coil
30	81 25 360	1	Rotor relief valve assembly (see page 51)
31	80 13 456	1	Gearbox / pump assembly (see page 43)
32	85 01 132	2	Hose 3/4" BSP x 212"long-Flail motor
33	85 38 075	1	Hose 3/4" BSP x 20"long Pump-R.C. Valve

HYDRAULIC INSTALLATION FOR R.HAND HI POWER MACHINES

29	71 36 143	3	Hose armour coil
30	81 25 400	1	Rotor Relief valve assembly (see page 51)
31	80 13 470	1	Gearbox/pump assembly (see page 45)
32	85 01 205	2	Hose 1" BSP x 212"long Flail motor
33	85 01 169	1	Hose 1" BSP x 29"long Pump- R.C. Valve

HYDRAULIC INSTALLATION FOR L. HAND HI POWER MACHINES

29	71 36 143	3	Hose armour coil
30	81 25 400	1	Rotor Relief valve assembly (see page 51)
31	80 13 569	1	Gearbox/pump assembly (see page 45)
32	85 01 205	2	Hose 1" BSP x 212" long-Flail motor
33	85 01 201	1	Hose 1" BSP x 17" long Pump R.C. Valve

CONTROL VALVE



McCOMEL

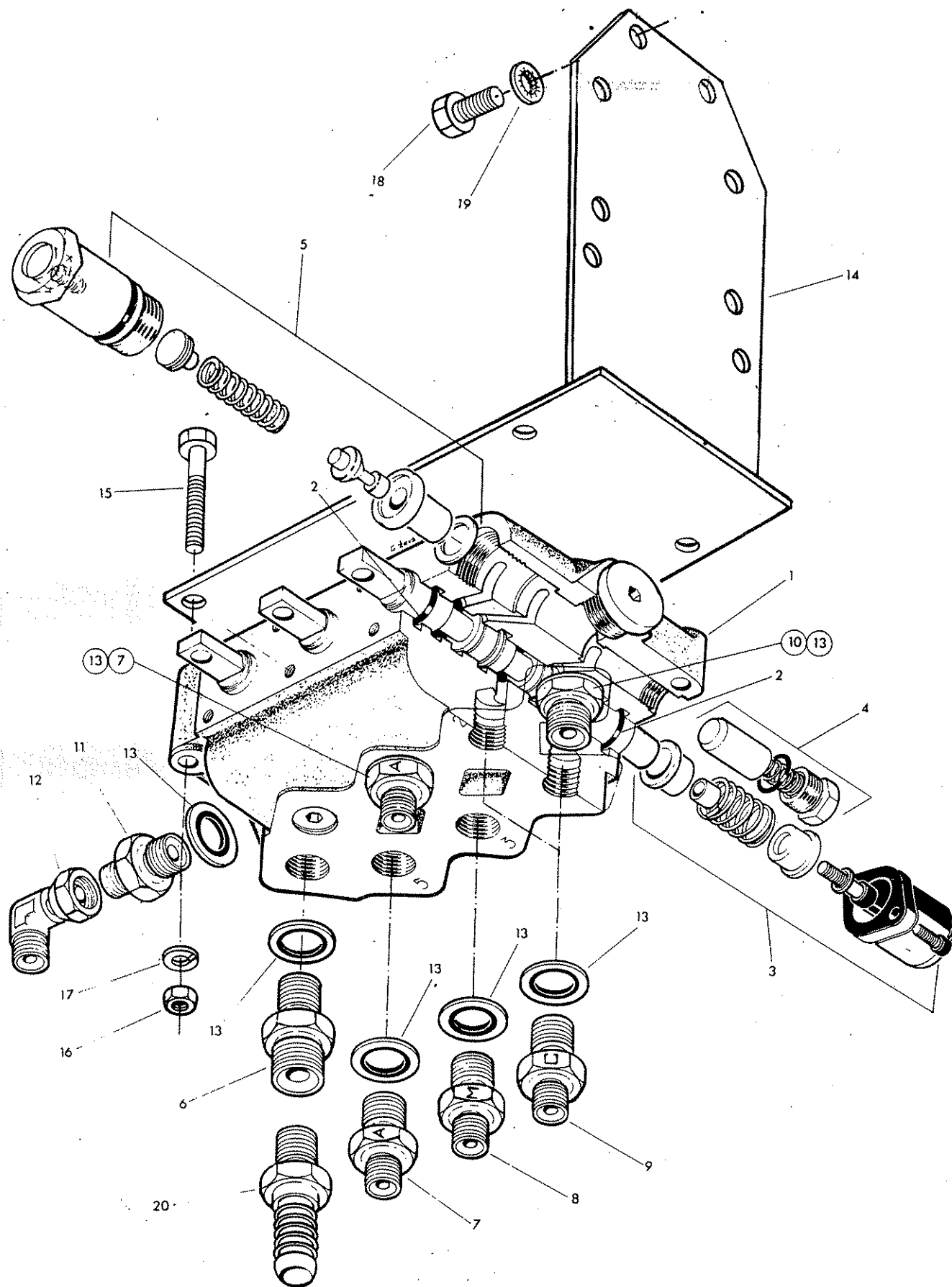



Ref.	Part No.	Qty.	Description
	81-30-372		HYDRAULIC CONTROL ASSEMBLY FOR PA 93 SEMI INDEPENDENT MODEL
	81-30-376	1	Valve c/w connections
1	81-30-334	1	Valve block c/w spools 'O' rings
2	86-00-112	6	'O' ring
3	81-30-134	3	Centering spring assembly
4	81-30-022	1	Non-return valve assembly
5	G381-2539	1	Relief valve assembly
6	60-00-112	1	Union
7	81-30-046	2	Restrictor union A
8	81-30-066	1	Restrictor union M
9	81-30-048	2	Restrictor union 'C'
10	60-00-113	1	Union
11	85-81-115	1	Union
12	85-81-190	1	Elbow
13	86-50-103	8	Bonded seal
14	71-93-322	1	Valve mounting plate
15	92-13-124	3	Bolt
16	91-13-004	3	Nut
17	91-00-204	3	Spring washer
18	93-13-045	2	Setscrew
19	91-00-305	2	Internal serrated washer dia

86-00-163

SEAL KIT

81-30-371

HYDRAULIC CONTROL ASSEMBLY FOR PA 93 FULLY INDEPENDENT MODEL

The parts list is identical to above with the following exceptions.

Second line becomes

81-30-375 1 Valve c/w connections

Item 6 becomes

81-25-008 1 Return connection 5/8" bore
Lever control. See following page

LEVER CONTROLS



McCONEL

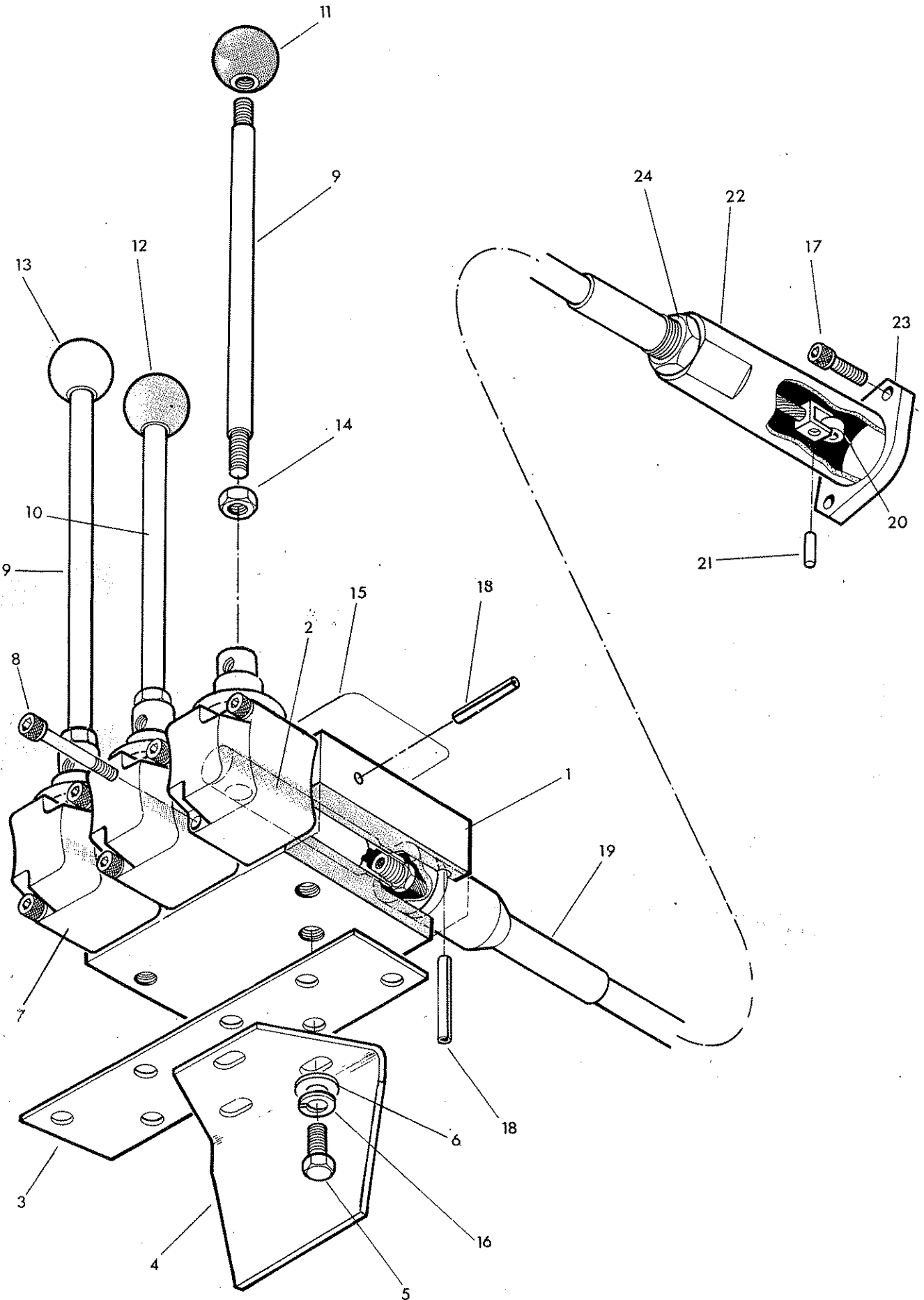



Ref.	Part No.	Qty.	Description
	81 30 371		HYDRAULIC CONTROL ASSY FOR T.I MODELS Continued
	81 30 372		HYDRAULIC CONTROL ASSY FOR S.I. MODELS Continued
1	81 30 391	1	Control block
2	81 30 144	3	Control block spindle
3	71 14 071	1	Control block mounting base
4	80 17 006	1	Mounting bracket
5	93 13 034	3	Setscrew
6	01 00 102	3	Thin washer
7	81 30 065	3	Lever pivot box assembly
8	92 43 072	6	Socket headed capscrew
9	71 09 131	2	Lever handle long
10	71 09 132	1	Lever handle short
11	09 03 112	1	Lever knob Reach (Red)
12	09 03 113	1	Lever knob Angle (Green)
13	09 03 114	1	Lever knob Lift (Yellow)
14	91 13 004	3	Hexagon nut
15	12 90 368	1	Operating instruction label
16	91 00 204	3	Spring washer
17	93 43 022	6	Socket headed capscrew
18	04 25 540	6	Spring dowel
19*	81 25 046	3	Cable & spacer & pin, sleeve, flange etc
20	71 15 158	1	Spool eye bush
21	71 15 160	1	Pin
22	71 15 162	1	Sleeve
23	81 25 050	1	Flange
24	01 31 006	1	Thin locknut

***Spare Note**

An alternative cable assembly may be fitted depending on supply availability

The complete assembly is interchangeable and retains the same PartNumber 81 25 046

Individual cable components are not interchangeable thus before ordering spares the cable must be correctly identified

The cable listed above is BLACK

The alternative cable is RED and consists of

19	81 25 046	1	Cable assembly incl sleeve, flange etc
20	81 25 049	1	Cable sleeve
21	81 25 050	1	Flange
22	81 25 051	1	Pin
23	91 00 016	1	Thin locknut
24	80 17 004	1	Spool eye bush

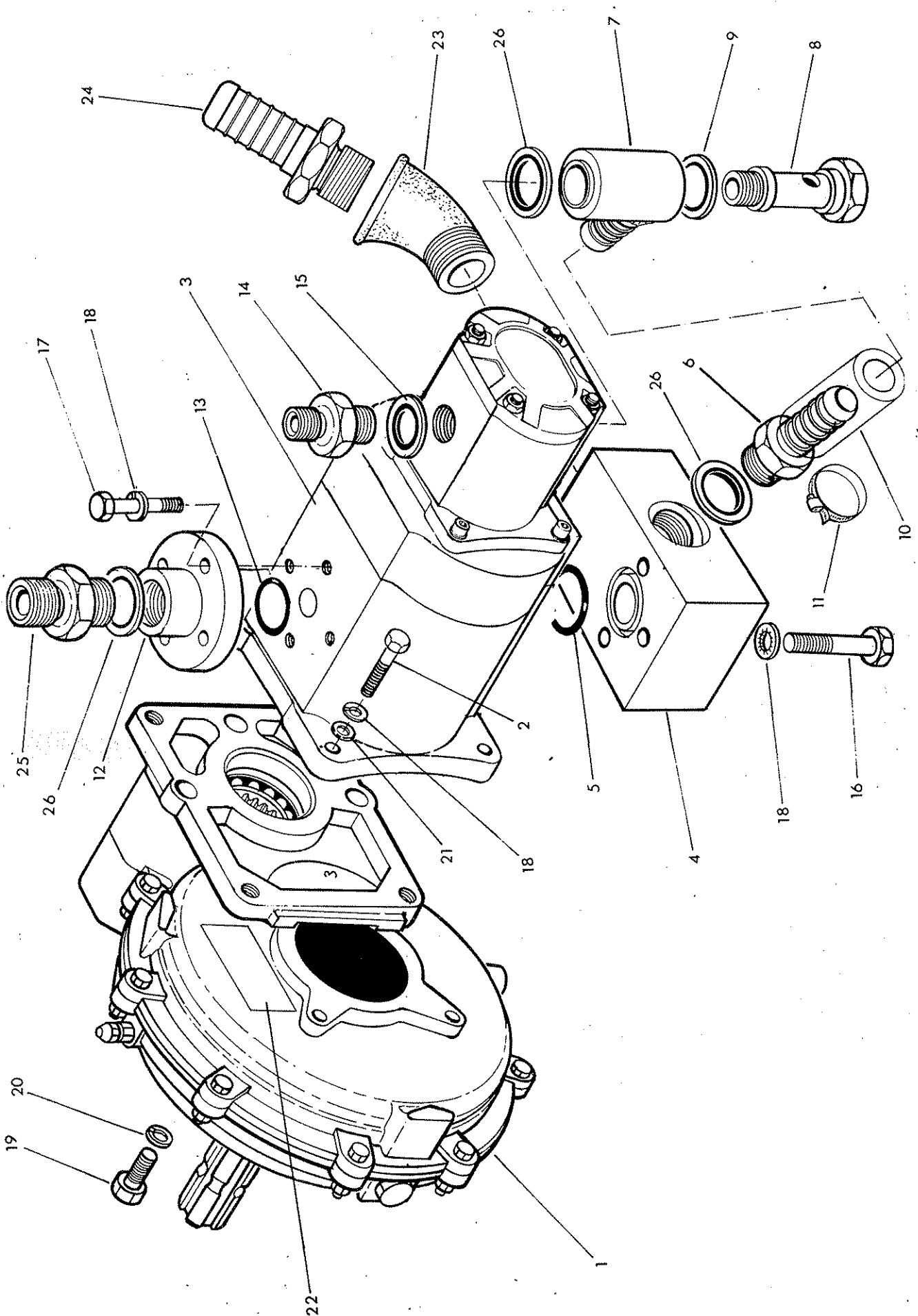
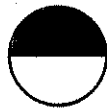



Ref	Part No	Qty	Description
	80 13 459		GEARBOX PUMP ASSEMBLY -FOR STD. POWER T.I.M/CS R.HAND
	80 13 458		GEARBOX PUMP ASSEMBLY FOR STD. POWER T.I.M/CS L.HAND

The parts list for right and left hand is identical. Assemblies vary only in build arrangement and comprise:-

1	86 13 444	1	Gearbox
2	92 13 094	4	Bolt
3	82 01 466	1	Tandem pump CPL 33/5.7 - as shown -Compr.
	82 01 664	1	Large pump
	82 01 667	1	Small pump
	82 01 466	1	Tandem pump - cast iron end plate - alternative build compr:-
	82 01 684	1	Large pump
	82 01 677	1	Small pump
4	71 92 371	1	Suction block
5	86 00 122	1	'O' ring
6	85 81 301	1	Adaptor
7	80 13 096	1	Banjo
8	80 13 095	1	Banjo bolt
9	86 50 107	1	Bonded seal
10	85 01 213	1	Connecting hose
11	09 04 204	2	Hose clip
12	80 13 088	1	Pump flange
13	86 00 119	1	'O' ring
14	60 00 112	1	Adaptor
15	85 50 104	1	Bonded seal
16	92 13 144	3	Bolt
17	93 13 054	4	Setscrew
18	91 00 404	11	Shakeproof washer
19	93 13 056	4	Setscrew
20	91 00 206	4	Spring washer
21	91 00 104	7	Plain washer
22	12 90 054	1	Gearbox label
23*	85 81 283	1	Elbow
24*	85 81 367	1	Adaptor
25	85 81 136	1	Union
26	86 50 106	3	Bonded seal

86 99 215

PUMP SEAL KIT -33/5.7

86 99 231

PUMP SEAL KIT -Cast iron end plate

***Assembly note :-** tems 20 and 21 to be assembled using PTFE tape

Spares note :- Check pump identification carefully before ordering section replacements.

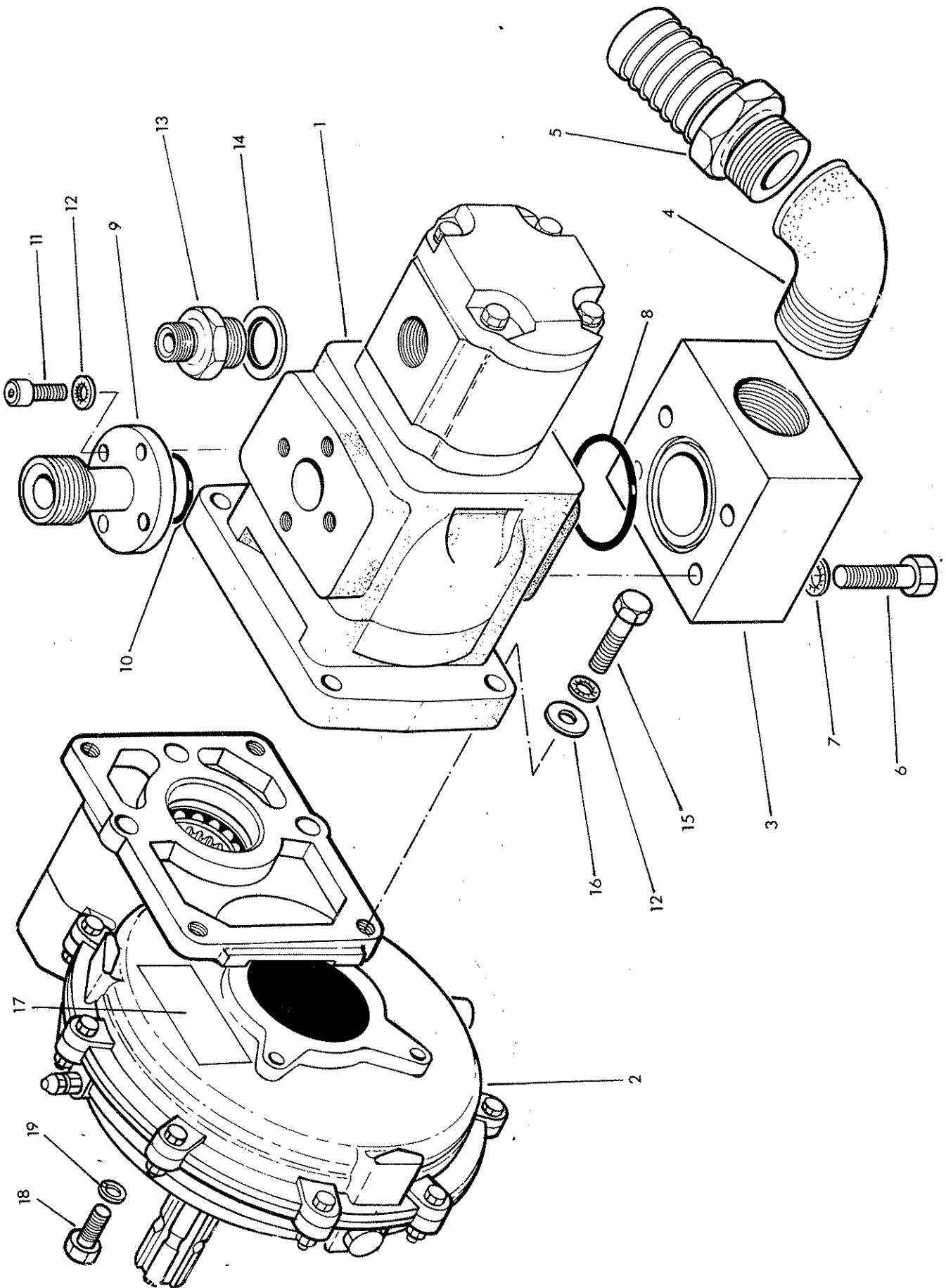
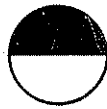



Ref	Part No	Qty	Description
			T.I PUMP AND GEARBOX L.HAND HI POWER - as illustrated
			T.I PUMP AND GEARBOX R.HAND HI POWER
The parts list for right and left hand is identical. Assemblies vary only in build arrangement and comprise:-			
1	82 01 685	1	Tandem pump compr:-
	82 01 165	1	Large-pump
	82 01 166	1	Small-pump
2	80 13 444	1	Gearbox
3	85 81 312	1	Suction flange
4	85 81 261	1	Elbow 90 degrees
5	85 81 367	1	Adaptor
6	92 13 146	4	Bolt
7	91 00 406	4	Shakeproof washer
8	86 00 304	1	'O' ring
9	80 13 090	1	Pressure connection
10	86 00 117	1	'O' ring
11	93 43 054	4	Cap screw
12	91 00 404	8	Shakeproof washer
13	60 00 112	1	Adaptor
14	86 50 104	1	Bonded seal
15	93 13 074	4	Bolt
16	91 00 104	4	Plain washer
17	12 90 054	1	Gearbox label
18	93 13 056	4	Setscrew
19	91 00 206	4	Spring washer
	86 99 234		SEAL KIT

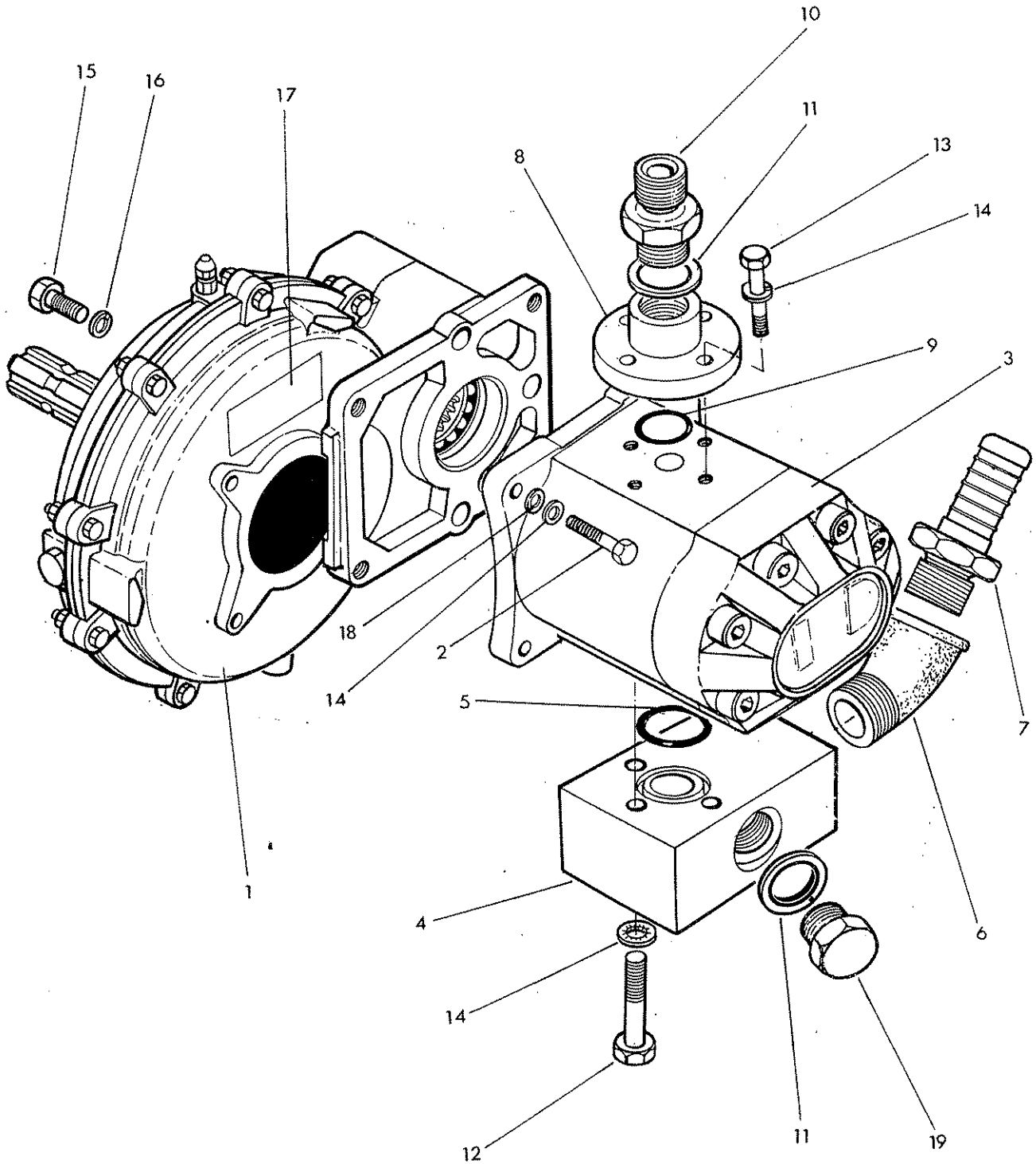



Ref	Part No	Qty	Description
	80 13 457		GEARBOX PUMP ASSEMBLY FOR STANDARD POWER S.I. MACHINES R.HAND
	80 13 456		GEARBOX PUMP ASSEMBLY FOR STANDARD POWER S.I. MACHINE L.HAND

The parts list for right and left hand is identical. Assemblies vary only in build arrangement and comprise:-

1	80 13 444	1	Gearbox -see page 47
2	92 13 094	4	Bolt
3	82 01 463	1	Pump CPL 33/5.7 - as shown
	82 01 463	1	Pump - cast iron end plate - alternative build
4	71 92 371	1	Suction block
5	86 00 122	1	'O' ring
6*	85 81 283	1	Elbow
7*	85 81 367	1	Adaptor
8	80 13 088	1	Pump flange
9	86 00 119	1	'O' ring
10	85 81 136	1	Union
11	86 50 106	2	Bonded seal
12	92 13 144	3	Bolt
13	93 13 054	8	Setscrew
14	91 00 404	11	Shakeproof washer
15	93 13 056	4	Setscrew
16	91 00 206	4	Spring washer
17	12 90 054	1	Gearbox label
18	91 00 104	7	Plain washer
19	85 81 302	1	Plug

86 99 215

PUMP SEAL KIT -33.5.7

86 99 231

PUMP SEAL KIT - Cast iron end plate

***Assembly note**

Items 6 & 7 to be assembled using PTFE tape

Spares note

Check pump carefully to correctly identify before ordering section replacements.

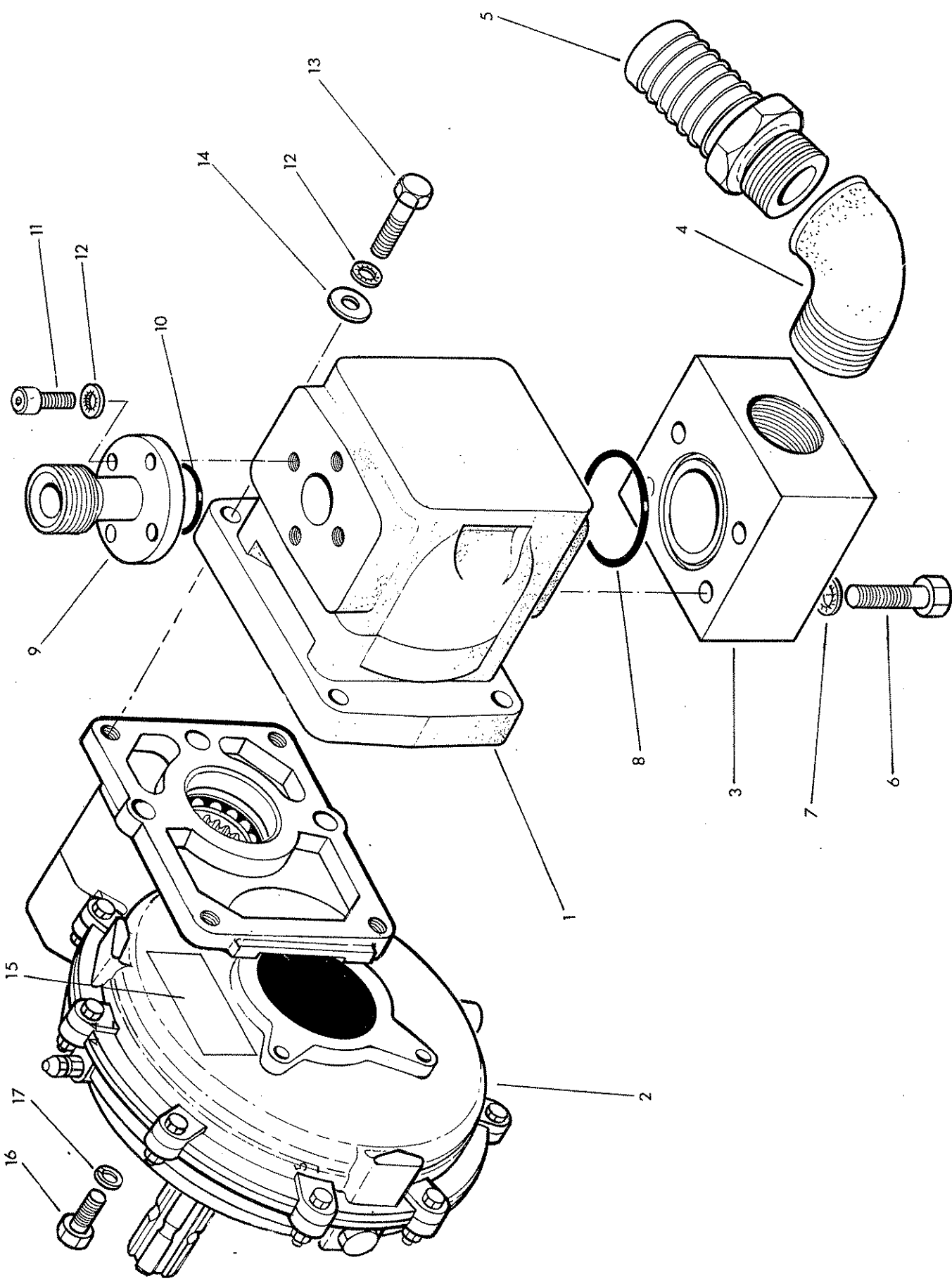



Ref	Part No	Qty	Description
			S.I PUMP AND GEARBOX R.HAND HI POWER -
			S.I PUMP AND GEARBOX L.HAND HI POWER - as illustrated

The parts list for right and left hand is identical. Assemblies vary only in build arrangement and comprise:-

1	82 01 686	1	Pump
2	80 13 444	1	Gearbox
3	85 81 312	1	Suction flange
4	85 81 261	1	Elbow
5	85 81 367	1	Adaptor low pressure
6	92 13 146	4	Bolt
7	91 00 406	4	Shakeproof washer
8	86 00 304	1	'O' ring
9	80 13 090	1	Pressure connection
10	86 00 117	1	'O' ring
11	93 43 054	4	Cap screw
12	91 00 404	8	Shakeproof washer
13	93 13 074	4	Bolt
14	91 00 104	4	Plain washer
15	12 90 054	1	Gearbox label
16	93 13 056	4	Setscrew
17	91 00 206	4	Spring washer
	86 99 235		SEAL KIT

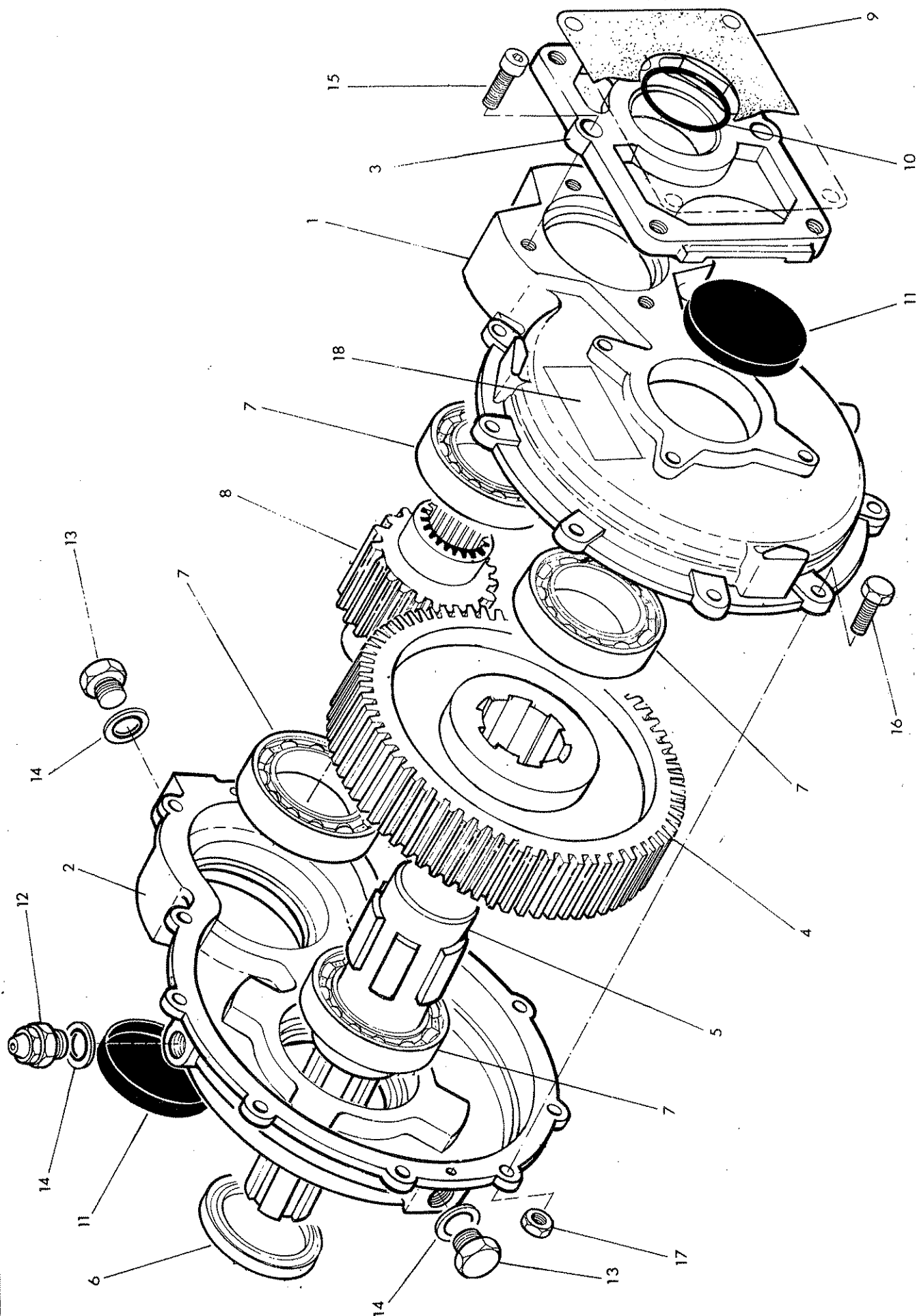

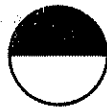

Ref	Part No	Qty	Description
	80 13 444		GEARBOX
1	80 13 100	1	Case - output side
2	80 13 101	1	Case - input side
3	80 13 102	1	Pump mounting flange
4	80 13 105	1	Gear
5	80 13 105	1	Shaft
6	86 29 196	1	Shaft seal
7	06 00 042	4	Bearing
8	80 13 104	1	Pinion
9	80 13 056	1	Gasket
10	86 00 523	1	'O' ring
11	80 13 106	2	End cover
12	80 13 107	1	Breather/adaptor
13	85 81 133	4	Plug
14	86 50 102	4	Bonded seal
15	93 43 045	3	Capscrew socket headed
16	92 13 064	10	Bolt
17	91 43 004	10	Self locking nut
18	12 90 054	1	Sticker

ROTOR CONTROL VALVE



McCONNEL

T.I. only

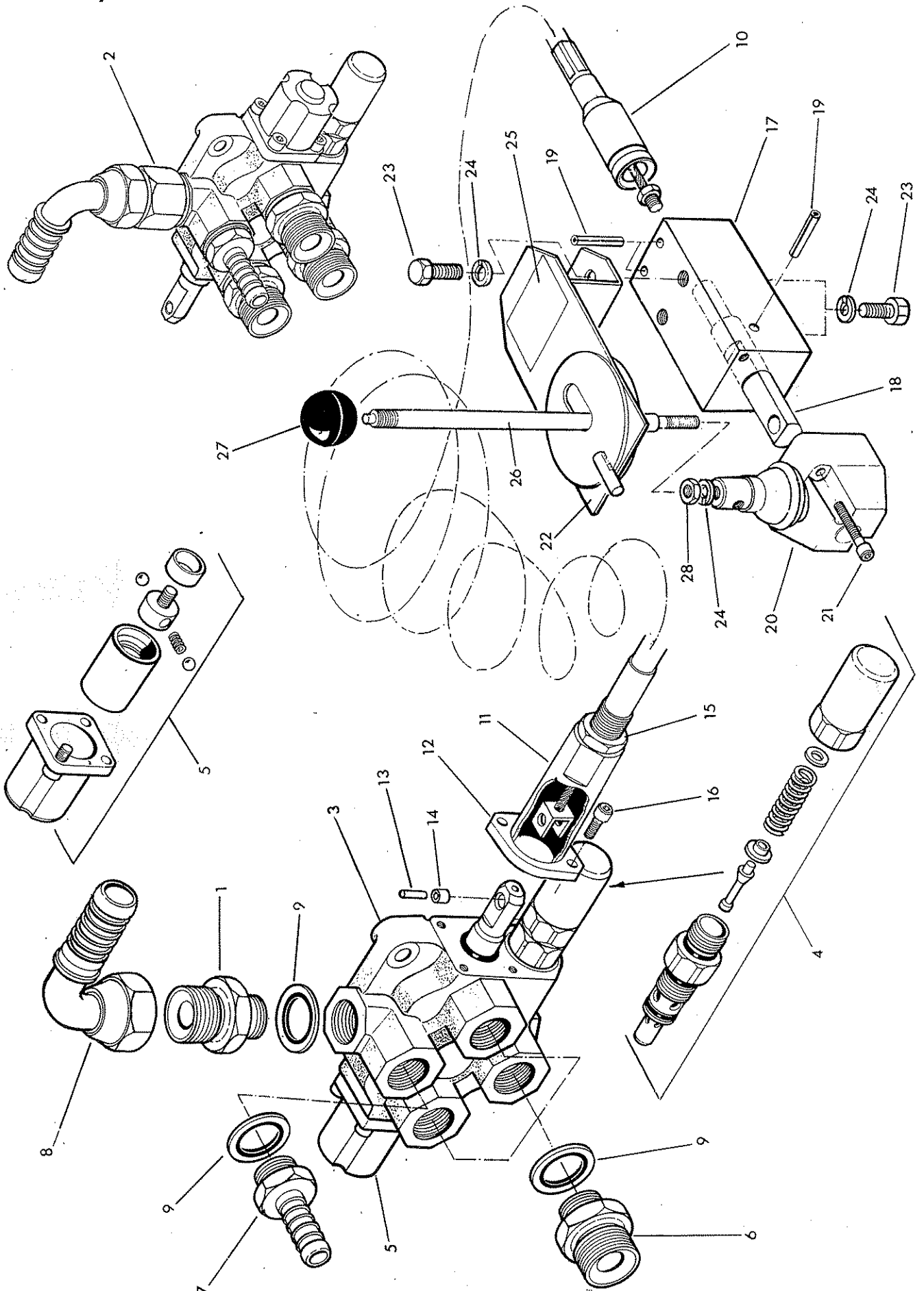



Ref.	Part No.	Qty.	Description
	81 25 377		ROTOR CONTROL VALVE ASSEMBLY T.I. MACHINES STD POWER R. HAND shown exploded
1	80 02 086	1	Adaptor
	81 25 378		ROTOR CONTROL VALVE ASSEMBLY T.I. MACHINES STD POWER L. HAND - shown inset
2	85 81 295	1	Extended adaptor

Items 3 -28 inclusive are common to both R and L Hand std power rotor valves

3	81 25 355	1	Rotor control valve
4	81 25 107	1	Relief valve
5	81 25109	1	Detent assembly
6	85 81 136	3	Union
7	85 81 269	1	Adaptor 3/4" BSP x 5/8" low pressure connection
8	71 14 005	1	Elbow 1" BSP F-1" low pressure connection
9	86 50 106	5	Bonded seal
10	81 25 102	1	Cable assembly c/w sleeve flange etc
11	81 25 097	1	Sleeve
12	81 25 098	1	Flange
13	81 25 099	1	Pin
14	81 25 100	1	Bush
15	01 31 006	1	Thin locknut
16	93 43 033	2	Capscrew - socket headed
17	81 25 093	1	Control block
18	81 30 053	1	Control spindle
19	05 25 525	3	Spring dowel dia
20	81 30 065	1	Pivot box assembly
21	92 13 072	2	Capscrew - socket headed
22	81 25 089	1	Lever control gate
23	93 13 034	4	Setscrew
24	91 00 204	5	Spring washer
25	12 90 338	1	Operating label
26	71 14 072	1	Lever
27	09 03 121	1	Knob - black
28	91 13 004	1	Thin nut

86 99 218 SEAL KIT

**81 25 379 ROTOR CONTROL VALVE ASSEMBLY T.I.
MACHINES HI POWER R. HAND**

**81 25 380 ROTOR CONTROL VALVE ASSEMBLY T.I.
MACHINES HI POWER L. HAND**

The parts list are identical with their std power counterparts except the following

3	81 25 356	1	Rotor control valve incl. relief valve and detent
4	81 25 108	1	Relief valve incl 'O' rings
6	80 02 086	3	Adaptor

ROTOR RELIEF VALVE



McCONEL

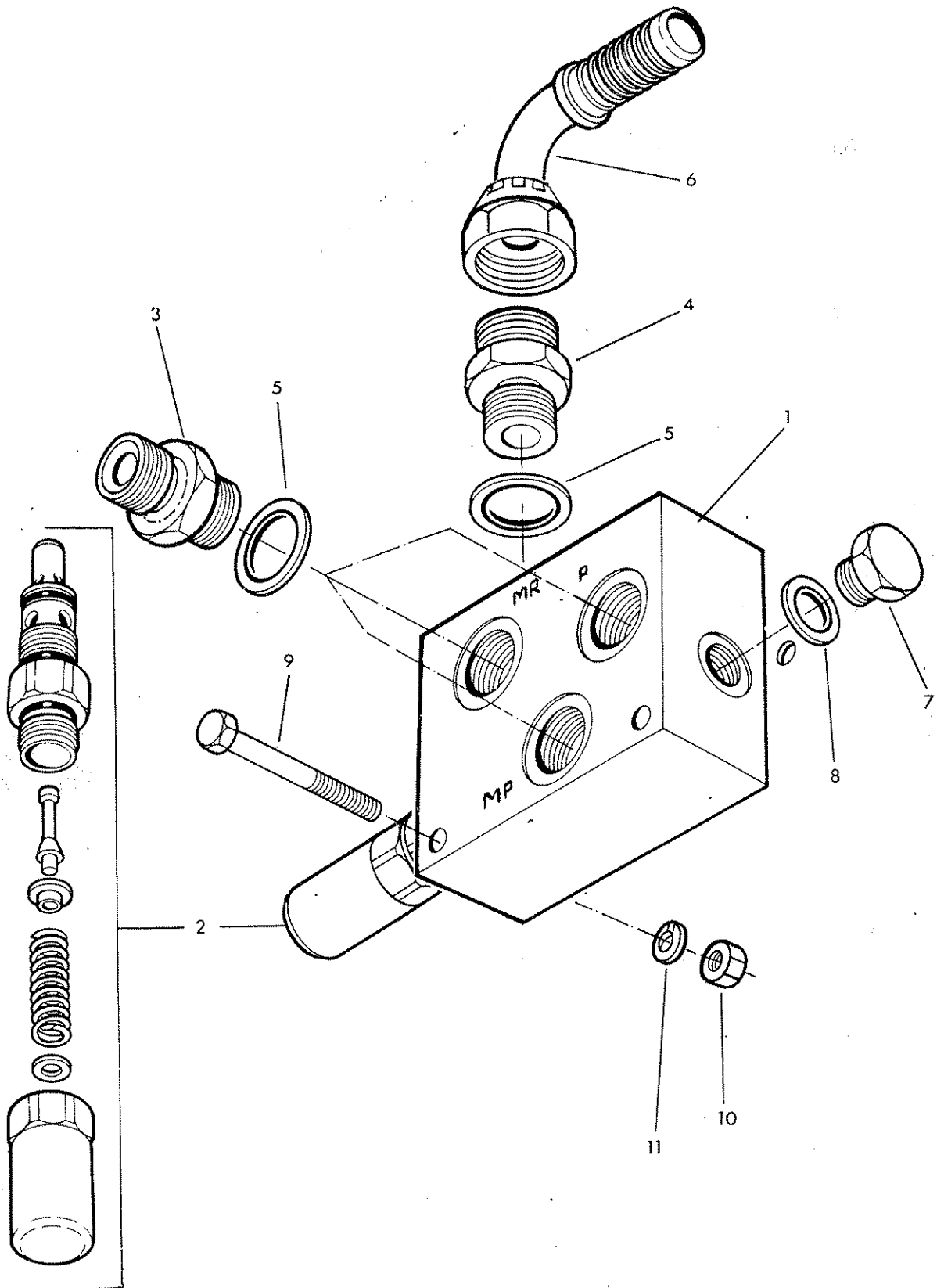



Ref.	Part No.	Qty.	Description
	81 25 360		ROTOR RELIEF VALVE ASSEMBLY -STD POWER (SI MODELS ONLY)
1	81 25 352	1	Valve block
2	81 25 107	1	Relief valve cartridge incl. 'O' rings
3	85 81 136	3	Union
4	80 02 086	1	Adaptor
5	86 50 106	4	Bonded seal
6	71 14 005	1	Swept 90 elbow
7	80 03 001	1	Plug
8	86 50 103	1	Bonded seal
9	92 13 135	2	Bolt
10	91 13 005	2	Nut
11	91 00 205	2	Spring washer
	81 25 400		ROTOR RELIEF VALVE ASSEMBLY HI POWER (S.I MODELS ONLY)

The parts list is identical to above with the following exception

2	81 25 108	1	Relief valve cartridge incl. 'O'ring
3	80 02 086	3	Adaptor

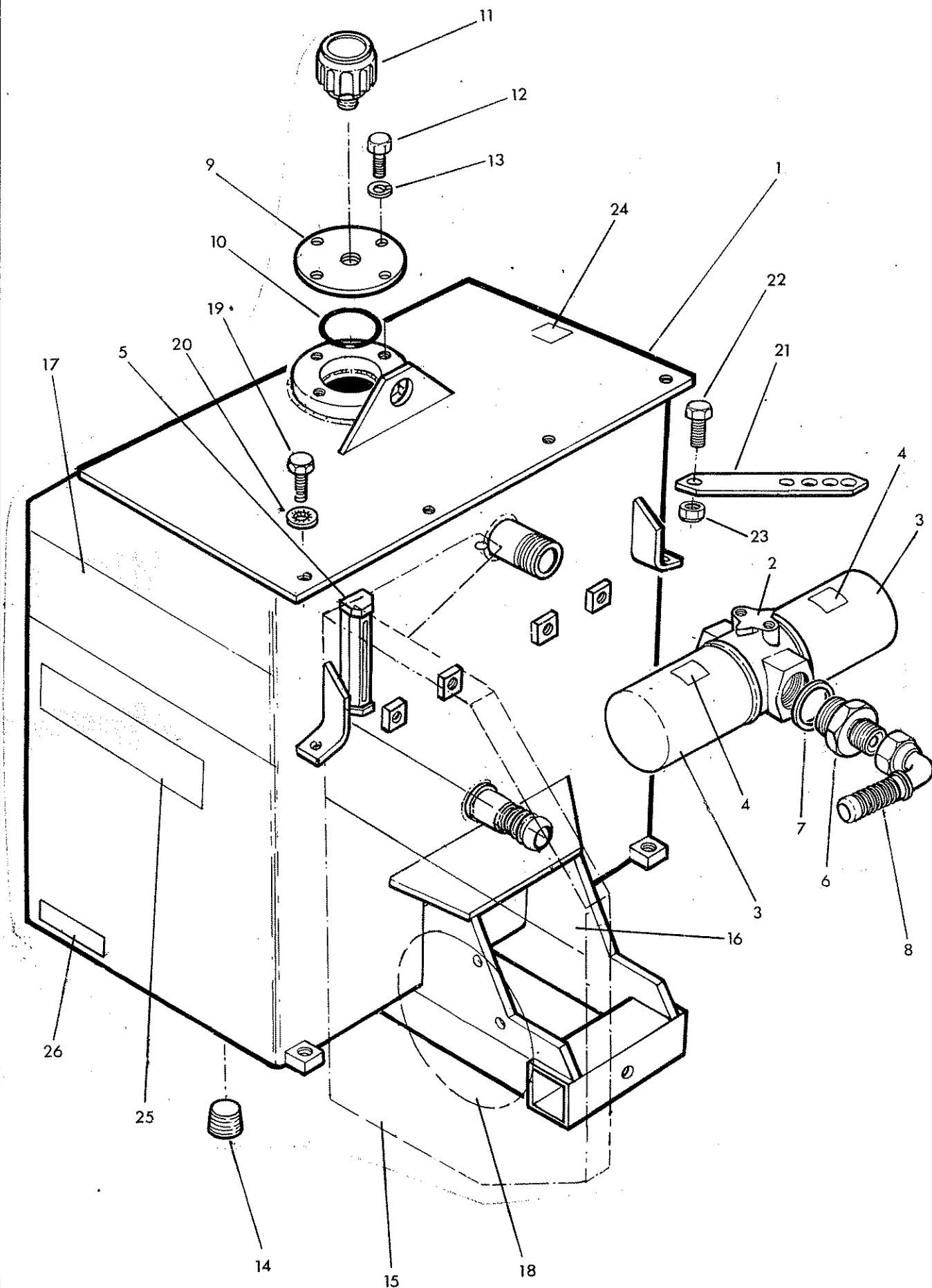



Ref	Part No	Qty	Description
ENDURO HYDRAULIC TANK AND COVER PLATE			
	71 93 392		Oil tank assembly compr:-
1	71 93 386	1	Oil tank
2	84 01 060	1	Return filter head
3	84 01 041	2	Filter element
4	12 90 023	2	Sticker "filter instructions"
5	84 01 048	1	Level guage
6	85 81 291	1	Union
7	86 50 224	1	Bonded seal
8	71 14 005	1	Elbow
9	71 92 062	1	Cover
10	86 00 151	1	'O' ring
11	84 01 063	1	Breather
12	93 13 054	4	Set screw
13	91 00 204	4	Spring washer
14	85 81 203	1	Drain plug
15	71 93 389	1	Cover plate R. hand
16	12 90 283	1	Stripe - R. hand
17	12 90 287	1	Tank stripe PA93
18	12 90 365	1	Sticker 'McConnel' rounded
19	93 13 045	2	Set screw
20	91 00 305	2	Internal serrated washer
21	71 92 029	1	Tank strap
22	93 13 056	2	Set screw
23	91 43 006	2	Self locking nut
24	12 90 023	1	Label 'oil filter'
25	12 90 362	1	Sticker 'Hi Power'
26	12 90 053	1	Sticker 'Enduro'

ENDURO HYDRAULIC TANK AND COVER PLATE

Parts are identical to the R. hand assembly with the following exceptions.

15	71 93 390	1	Cover plate L. hand
16	12 90 284	1	Stripe L. hand

LIFT FLOAT KIT

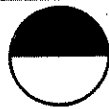

McCONEL

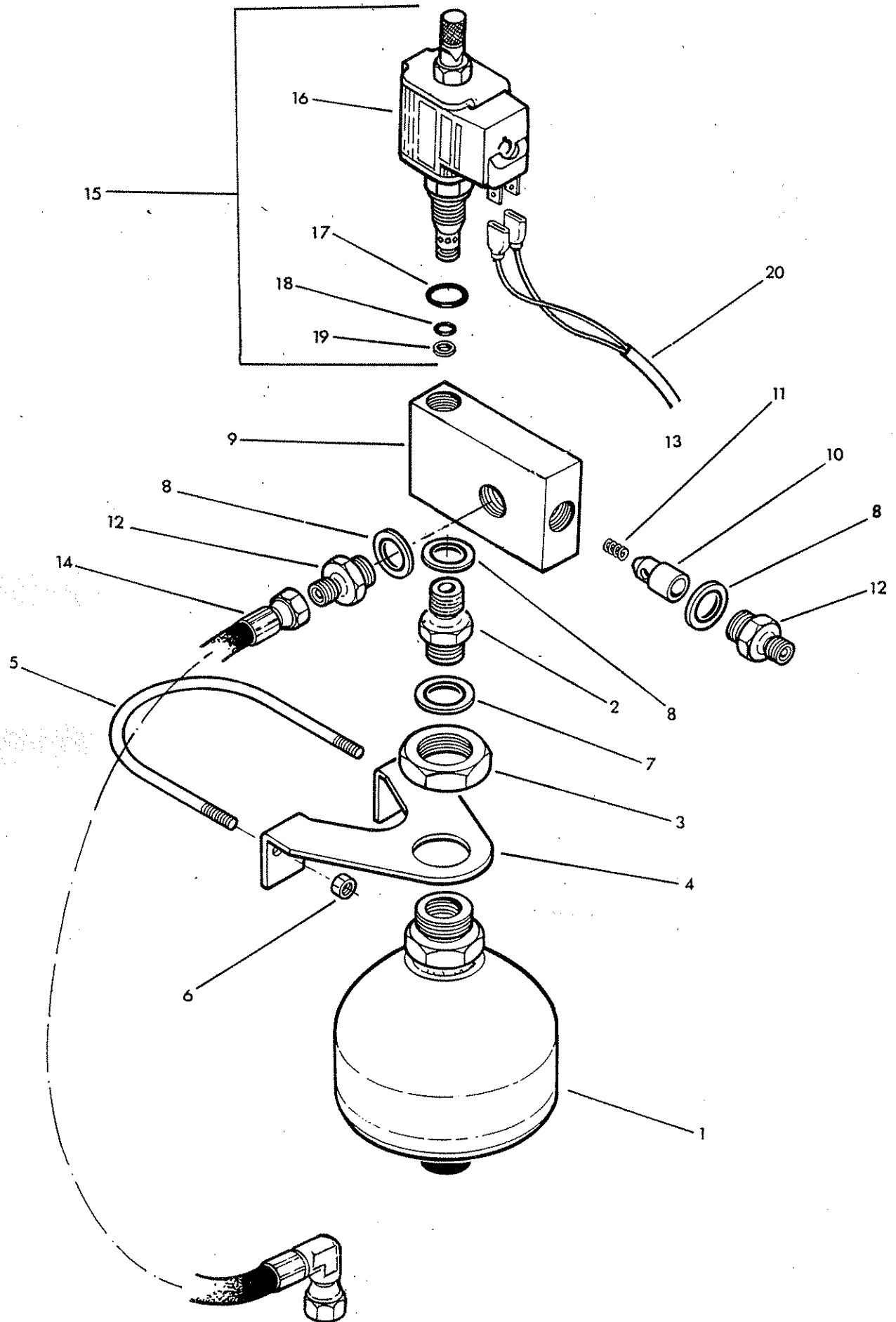

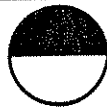

Ref.	Part No.	Qty.	Description
	81 26 290		LIFT FLOAT KIT - Quick response
1	81 26 042	1	Accumulator
2	G241 0380	1	Adaptor
3	81-26 035	1	Bulkhead nut
4	81 26 286	1	Bracket
5	81 26 031	1	U.bolt
6	91 43 004	2	Self locking nut
7	86 50 322	1	Bonded seal
8	86 50 103	3	Bonded seal
9	81 26 287	1	Control block
10	81 26 037	1	Response piston
11	81 16 011	1	Spring
12	85 81 115	2	Adaptor
13	12 90 061	1	Operating sticker
14	85 35 012	1	Hose 1/4" BSP x 12" long SF - 90F
15	81 30 183	1	Poppet valve including :-
16	81 30 184	1	Coil
17	87 00 017	1	O ring
18	87 00 511	1	O ring
19	87 09 511	1	Anti extrusion ring
20	84 02 159	1	Cable - electric machines only

LIFT RAM



MCCORMICK

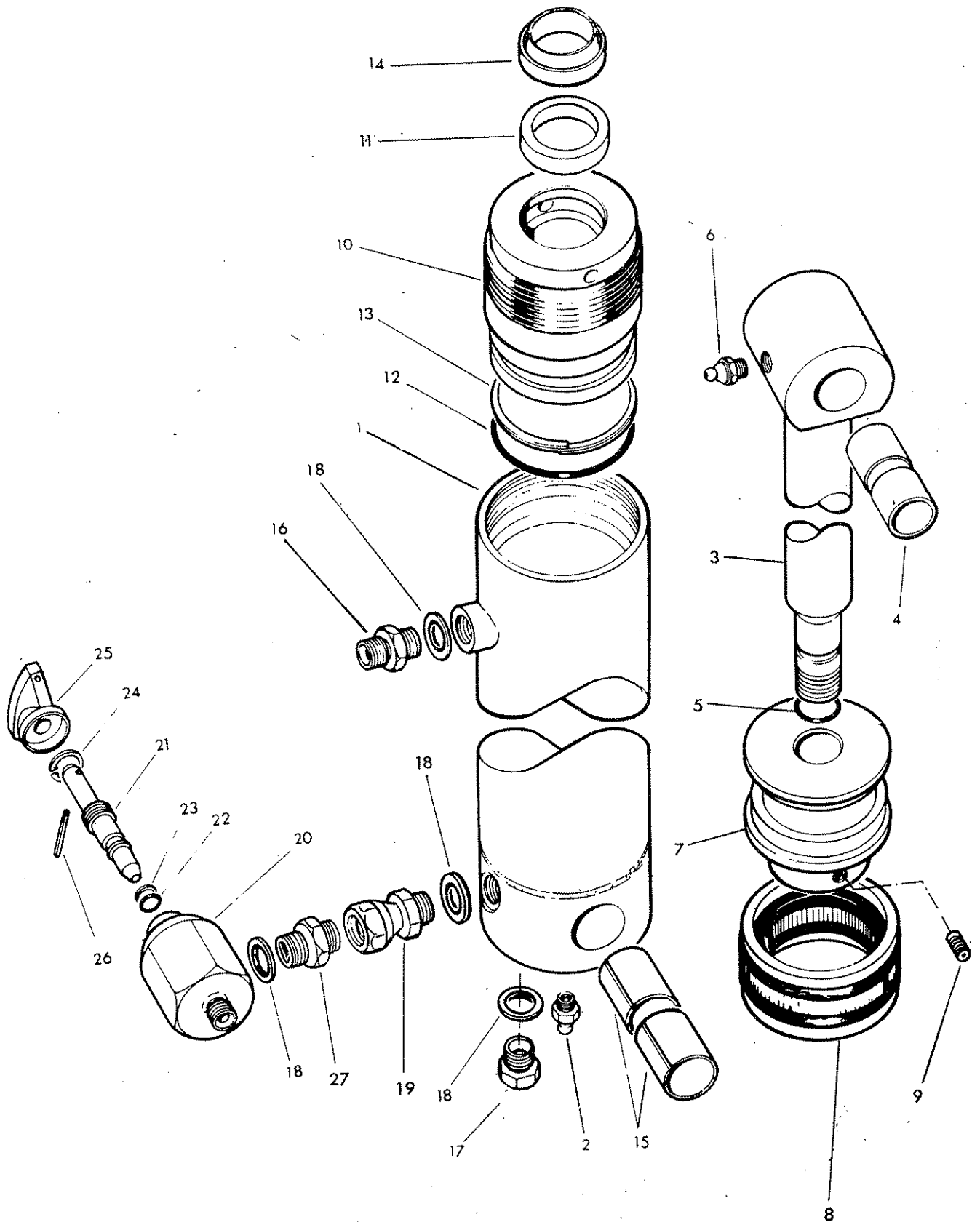



Ref.	Part No.	Qty.	Description
	71 93 333		LIFT RAM ASSEMBLY
1	71 35 283	1	Ram cylinder
2	09 01 121	1	Greaser
3	71 93 029	1	Piston rod
4	60 12 032	2	Bush
5	86 00 119	1	'O' ring
6	09 01 121	1	Greaser
7	71 35 004	1	Piston
8	86 38 740	1	Piston seal
9	93 63 023	1	Grub screw
10	71 35 282	1	Gland housing
11	86 29 164	1	Gland seal
12	87 00 740	1	'O' ring
13	87 09 740	1	Anti extrusion ring
14	86 29 147	1	Wiper
15	71 01 134	2	Bush - ram base
16	85 81 115	1	Union
17	80 03 001	1	Plug
18	86 50 103	4	Bonded seal
19	85 81 178	1	Swivel adaptor
	71 93 050	1	Lock tap assembly compr:
20	71 35 284	1	Tap body
21	71 35 006	1	Tap spindle
22	86 00 107	1	'O' ring
23	86 09 107	1	Anti extrusion ring
24	04 16 110	1	Internal circlip
25	81 08 006	1	Tap knob
26	04 20 820	1	Spring dowel
27	60 00 113	1	Union
	86 99 187		SEAL KIT

Assembly note Fully tighten item 9 and centre pop edge of hole to retain.

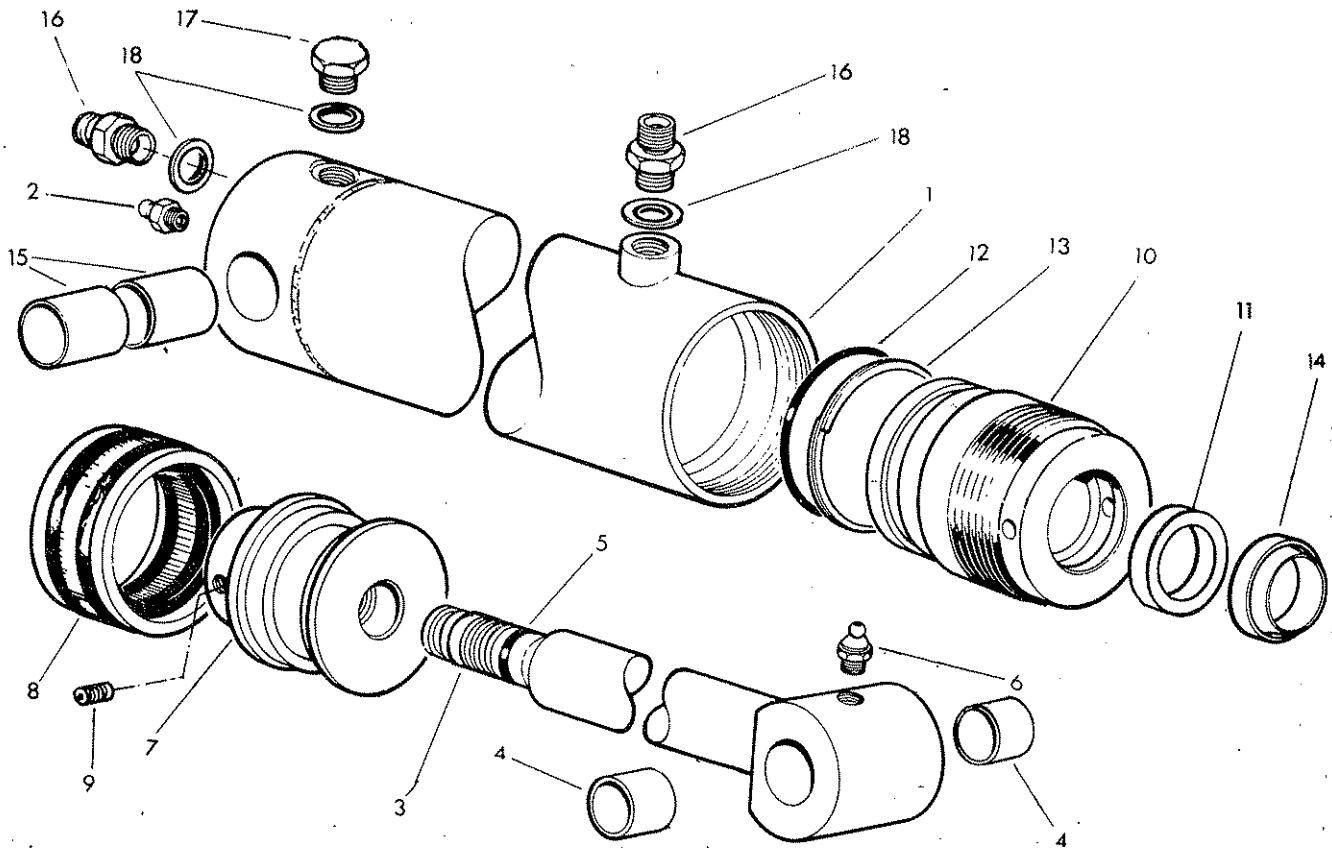
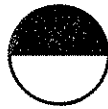

Ref.	Part No.	Qty.	Description
	71-93-334		REACH RAM ASSEMBLY
1	71-35-283	1	Ram cylinder
2	09-01-121	1	Greaser
3	71-93-029	1	Piston rod
4	60-12-032	2	Bush
5	86-00-119	1	'O' ring
6	09-01-121	1	Greaser
7	71-35-004	1	Piston c/w seal and grub screw
8	86-38-740	1	Piston seal
9	93-63-023	1	Grub screw
10	71-35-282	1	Gland housing
11	86-29-164	1	Gland seal
12	87-00-740	1	'O' ring
13	87-09-740	1	Anti extrusion ring
14	86-29-147	1	Wiper
15	71-01-134	2	Bush - ram base
16	85-81-115	2	Union
17	80-03-001	1	Plug
18	86-50-103	3	Bonded seal

86-99-187 SEAL KIT

Assembly note Fully tighten item 9 and centre pop edge of hole to retain.

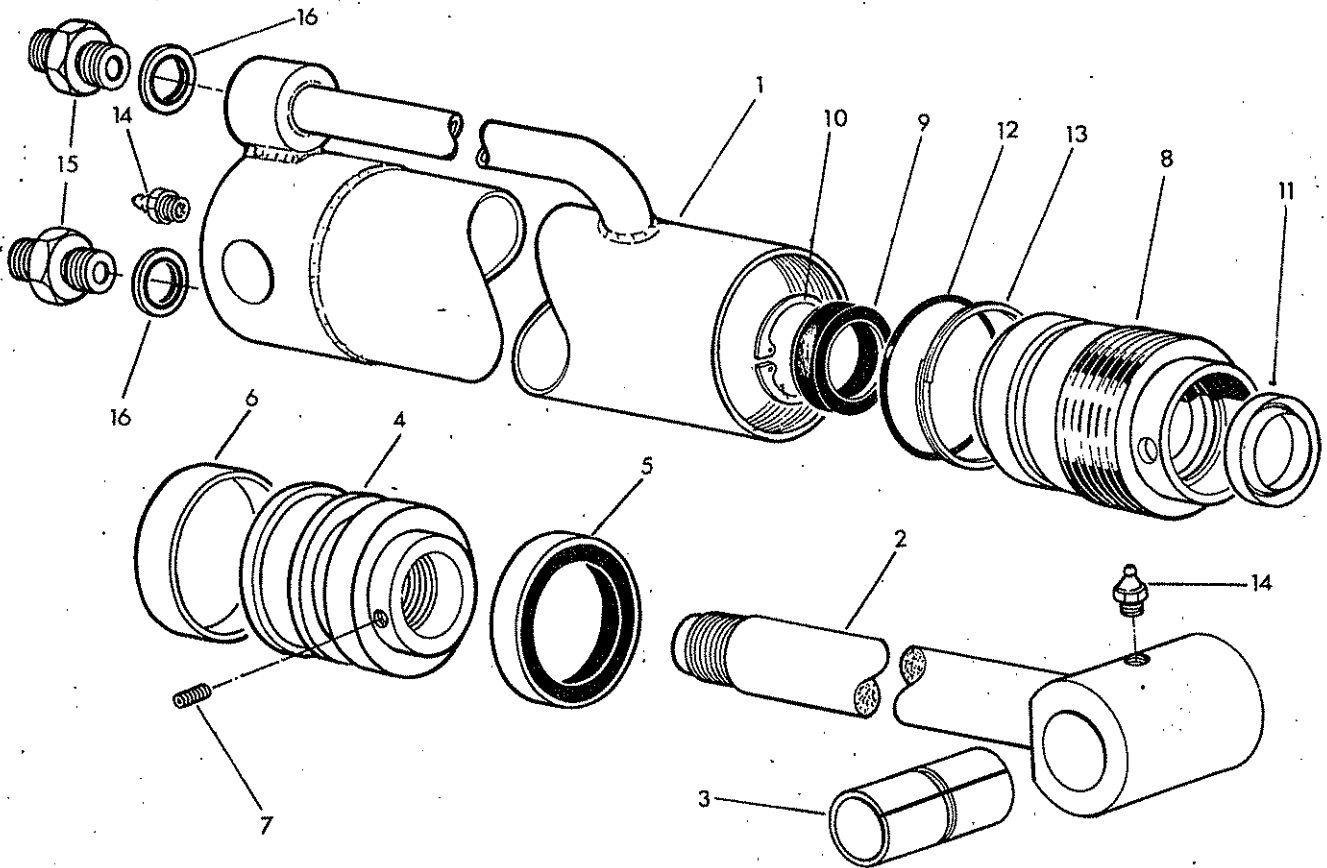

Ref.	Part No.	Qty.	Description
	75-60-344		ANGLING RAM ASSEMBLY
1	71-35-292	1	Cylinder
2	71-35-009	1	Rod
3	71-05-050	1	Bush
4	75-60-095	1	Piston
5	86-29-187	1	Piston seal
6	86-29-188	1	Bearing ring
7*	93-63-023	1	Grub screw socket head
8	71-35-291	1	Gland housing
9	86-29-148	1	Gland seal
10	04-16-240	1	Internal circlip
11	86-29-149	1	Wiper seal
12	86-00-302	1	'O' ring
13	86-09-302	1	Anti extrusion ring
14	09-01-121	2	Greaser
15	85-81-169	2	Union
16	86-50-102	2	Bonded seal
	86-99-188		SEAL KIT

*** Assembly note**

Tighten fully and centre punch edge of hole to secure.

1193

Modules: Refer to Parts List opposite

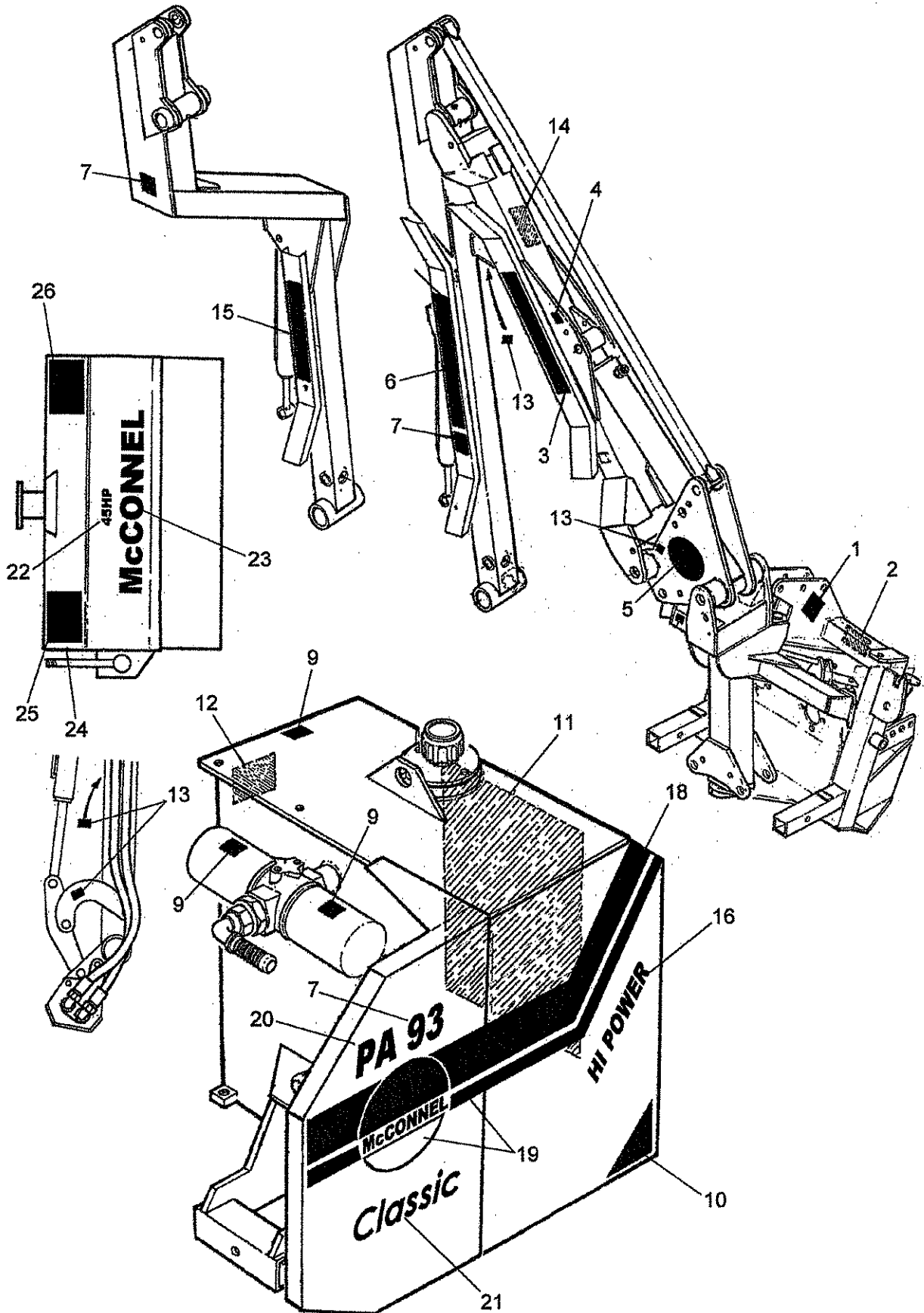



MACHINE DECALS

REF.	QTY.				PART No.	DESCRIPTION
					7193744	DECAL KIT - PA93 Std. Power Models
					7193745	DECAL KIT - PA93 High Power Models
					7193746	DECAL KIT - PA93 Midcut Std. Power Models
					7193747	DECAL KIT - PA93 Midcut High Power Models
1	1	1	1	1	7105130	DECAL - READ INSTRUCTION BOOK FIRST
2	1	1	1	1	7135295	DECAL - TIGHTEN CHECK CHAINS
3	1	1	1	1	1290255	DECAL - McCONNEL
4	1	1	1	1	1290074	DECAL - SLING HERE SYMBOL
5	1	1	1	1	1290296	DECAL - ROUNDEL LOGO
6	1	1	-	-	1290295	DECAL - POWER ARM
7	2	2	2	2	1290293	DECAL - 93 (<i>Cable Models</i>)
	2	2	2	2	1290394	DECAL - 93E (<i>Electric Models</i>)
8	1	1	1	1	1290352	DECAL - GENERAL WARNING
9	3	3	3	3	1290023	DECAL - OIL FILTER INSTRUCTION
10	1	1	1	1	1290376	DECAL - ENDURO TANK
11	1	1	1	1	1290391	DECAL - GENERAL WARNING
12	1	1	1	1	00756494	DECAL - PTO SHAFT FITTING
13	6	6	6	6	02962764	DECAL - PINCH POINT SYMBOL
14	1	1	1	1	1290403	DECAL - BREAKAWAY RETURN WARNING
15	-	-	1	1	1290361	DECAL - MIDCUT
16	-	1	-	1	1290362	DECAL - HIGH POWER
17	1	1	-	-	1290295	DECAL - POWER ARM
18	1	1	1	1	1290454	DECAL - TANK STRIP DIAGONAL
19	1	1	1	1	1290455	DECAL - FAIRING STRIP DIAGONAL
20	1	1	1	1	1290453	DECAL - PA
21	1	1	1	1	1290551	DECAL - CLASSIC
						FLAILHEAD DECALS
22	1	-	1	-	1290509	DECAL - 45HP
	-	1	-	1	1290508	DECAL - 54HP
23	1	1	1	1	1290527	DECAL - McCONNEL
24	1	1	1	1	1290392	DECAL - PARTS INFORMATION
25	1	1	1	1	1290377	DECAL - FLAILHEAD INSTRUCTIONS
26	1	1	1	1	1290341	DECAL - FLAILHEAD GUARDING

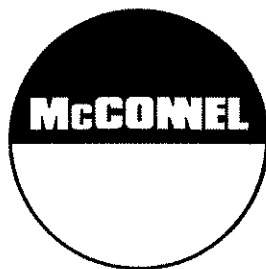

McConnel Limited, Temeside Works, Ludlow, Shropshire SY8 1JL. England.
Telephone: 01584 873131. Facsimile: 01584 876463. www.mcconnel.com