



## **Ersatzteilkatalog**

Spare parts catalogue

Catalogue de pièces de rechange

**Schlegelmulchgerät**

**Flail Mulcher**

**Broyeur**

**WM 85 - 145**



**Maschinenfabrik**

**Bermatingen GmbH & Co. KG**

Kesselbachstr. 2  
D-88697 Bermatingen

Telefon: +49 (0) 7544 / 9506 - 0  
Telefax: +49 (0) 7544 / 9506 - 43  
[www.humus-mulchgeraete.de](http://www.humus-mulchgeraete.de)



- 
- HINWEIS: Bei allen Ersatzteilbestellungen bitte die Serien-Nr. der Maschine angeben!
- NOTE: For all spare part orders, please indicate the serial number of the machine.
- NOTA: Pour commander des pièces détachées, veuillez indiquer le numéro de la machine.

Änderungen und Irrtümer vorbehalten!  
Technical changes and errors excepted!  
Sauf erreur, modification ou omission!

## Inhaltsverzeichnis / Table of Contents / Table des matières

<b>Grundmontage / Basic assembly / Montage de base</b> .....	<b>4</b>
<b>Anbau Dreipunkt leicht/ Three-Point linkage lightweight design/ Arceau à trois- point court construction légère</b> .....	<b>6</b>
<b>Anbau Dreipunkt schwer / Three-Point linkage heavy design/ Arceau à trois-point court lourde</b> .....	<b>8</b>
<b>Seitenverstellung / Side adjustment / déport latéral</b> .....	<b>10</b>
<b>Antrieb Nieder / Drive low / Entraînement à bas: 540 1/min &amp; 1000 1/min</b> .....	<b>12</b>
<b>Antrieb Hoch / Drive / Entraînement à haut: 540 1/min &amp; 1000 1/min</b> .....	<b>14</b>
<b>Rotorwelle/ Rotor shaft/ Axe batteur : SF; SK; Universal</b> .....	<b>16</b>
<b>Schlegelwelle mit Lager / Rotor shaft cpl./ Axe batteur cpl.: SF; SK; Universal</b> .....	<b>18</b>
<b>Klingenmesserwelle kpl. m. Lager / Rotor shaft, Y-type flails with bearings / Rotor porte couteaux Y avec palier</b> .....	<b>20</b>
<b>Klingenmesserwelle / Rotor shaft, Y-type flails / Rotor porte couteaux Y</b> .....	<b>22</b>
<b>Laufwalze / roller / rouleau stabilisateur</b> .....	<b>24</b>
<b>Fallklappen / Guard shutter / Barrette de protection</b> .....	<b>25</b>
<b>Bestellformular / Spare parts order form / Commande pièces détachées</b> .....	<b>27</b>

Hinweis:            Typ entspricht der Arbeitsbreite !  
Remark:            Type is equivalent to working width !  
Remarque:        Le type signifie la largeur de travail !

<b>Typ Type Type</b>	<b>Arbeitsbreite working width largeur de travail</b>
<b>85</b>	<b>850 mm</b>
<b>95</b>	<b>950 mm</b>
<b>105</b>	<b>1050 mm</b>
<b>115</b>	<b>1150 mm</b>
<b>125</b>	<b>1250 mm</b>
<b>135</b>	<b>1350 mm</b>
<b>145</b>	<b>1450 mm</b>

Grundmontage / Basic assembly / Montage de base

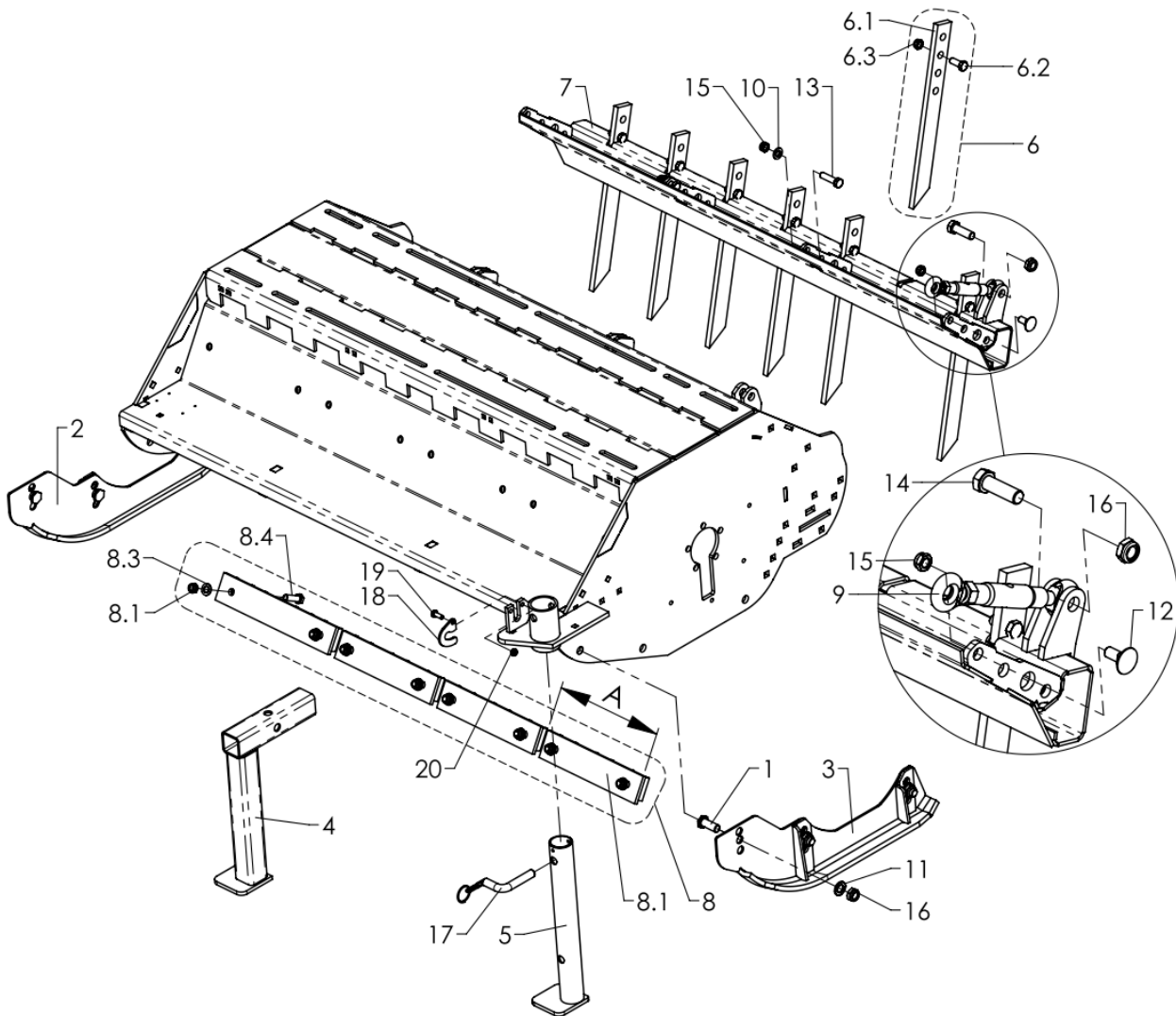

POS.	Code	Type	x	Bezeichnung	Description	Désignation	Info
1	M18391393		6	Befestigungsschraube	fixing screw	vis de fixation	
2	M18595012		1	Kufe rechts	skid right	glissière droite	
3	M18595112		1	Kufe links	skid left	glissière gauche	
4	M22995007	<b>135</b> <b>145</b>	1	Stützfuß	support leg	pieds d'appui	
5	M22495007	<b>85</b> <b>95</b> <b>105</b> <b>115</b> <b>125</b>	1	Stuetzfuss	support leg	pieds d'appui	

POS.	Code	Type	x	Bezeichnung	Description	Désignation	Info
6	M59095019	145 135	8	Zinken kpl. mit Schraube und Mutter	prong cpl.	dent cpl.	
		125 115	7				
		105 95/ 85	6				
6.1	M59091354		1	Zinken	prong	dent	
6.2	M90933028		1	Skt.-Schraube	hexagon screw	vis à six pans creux	M12x30
6.3	M90985006		1	Polystopmutter		Écrou auto-freiné	M12
7	M58995103	85	1	Zinkenhalter	tine bracket	dispositif de réception	
	M59195103	95					
	M59295103	105					
	M59395103	115					
	M59495103	125					
	M59695103	135					
	M59595103	145					
8	M58995121	85	1	Schlagleistensatz	shredding bar set	Set de barre de broyage	
	M59195121	95					
	M59295121	105					
	M59395121	115					
	M59495121	125					
	M59595121	135					
	M59695121	145					
8.1	M59095128			Schlagleiste A=330 mm	shredding bar A=330 mm	barre de broyage A=330 mm	
	M59095125			Schlagleiste A=280 mm	shredding bar A=280 mm	barre de broyage A=280 mm	
	M59095127			Schlagleiste A=230 mm	shredding bar A=230 mm	barre de broyage A=230 mm	
8.2	M90985006			Polystopmutter	prevailing torque	écrou auto-freiné	M12
8.3	M90125005			U-Scheibe	washer	rondelle	Ø13
8.4	M90933030			Sechskantschraube	hexagon screw	vis à six pans creux	M12x40
9	M84001006		1	Spannschloss	turnbuckle	tendeur à vis	
10	M90125005		2	U-Scheibe	washer	rondelle	Ø13
11	M90125008		6	U-Scheibe	washer	rondelle	Ø17
12	M90603017		2	Flachrundschrabe	carriage bolt	vis à tête bombée	M12x30
13	M90933055		2	Skt.-Schraube	hexagon screw	vis à six pans creux	M12x45
14	M90933071		2	Skt.-Schraube	hexagon screw	vis à six pans creux	M16x50
15	M90985006		4	Polystopmutter	prevailing torque	écrou auto-freiné	M12
16	M90985008		8	Polystopmutter	prevailing torque	écrou auto-freiné	M16
17	M59595014		1	Stuetzfußstecker	plug	fiche	
18	M52191490		1	Sicherungshaken			
19	M90933011		1	Skt.-Schraube	hexagon screw	vis à six pans creux	M8x20
20	M90985004		1	Polystopmutter	prevailing torque	écrou auto-freiné	M8

Anbau Dreipunkt leicht/ Three-Point linkage lightweight design/ Arceau à trois-point court construction légère

Leichtbauweise bis 34 kW

Lightweight desing up to 34 kW

Construction légère jusqu'à 34 kW

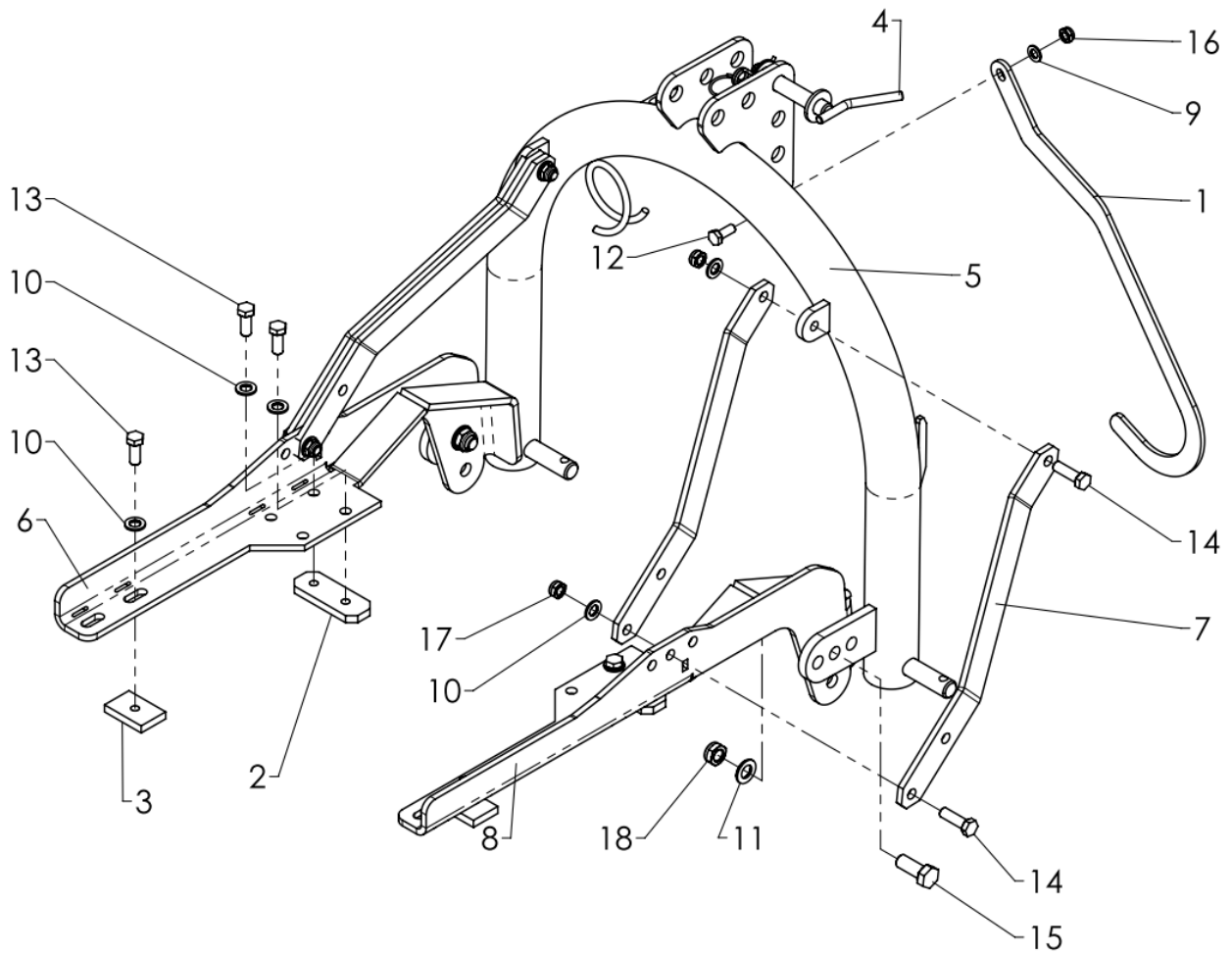

POS.	Code	x	Bezeichnung	Description	Désignation	Info
1	M19291336	1	Gelenkwellenhaken	shaft hook	support cardan	
2	M26691319	2	Gewindeplatte	threaded plate	plaque fileté	2 x M12
3	M26691489	2	Gewindeplatte	threaded plate	plaque fileté	1 x M12
4	M32595251	1	Steckbolzen kpl.	plug-in bolt	prise	
5	M32795032	1	Dreipunktbügel	three point frame	attelage trois-point	
6	M59091624	1	Dreipunktträger Re.	support three point frame	support	
7	M59091629	1	Dreipunktstütze	support three point frame	Support 3 points	
8	M59091639	1	Dreipunktträger Li.	support three point frame	Support gauche	
9	M90125004	1	U-Scheibe	washer	rondelle	
10	M90125005	10	U-Scheibe	washer	rondelle	Ø13
11	M90125008	2	U-Scheibe	washer	rondelle	Ø1
12	M90933020	1	Sechskantschraube	hexagon screw	vis à six pans creux	
13	M90933028	6	Sechskantschraube	hexagon screw	vis à six pans creux	M12x30
14	M90933030	4	Sechskantschraube	hexagon screw	vis à six pans creux	
15	M90933044	2	Sechskantschraube	hexagon screw	vis à six pans creux	
16	M90985005	1	Polystopmutter	prevailing torque	écrou auto-freiné	M10
17	M90985006	4	Polystopmutter	prevailing torque	écrou auto-freiné	M12
18	M90985008	2	Polystopmutter	prevailing torque	écrou auto-freiné	M16

Anbau Dreipunkt schwer / Three-Point linkage heavy design/ Arceau à trois-point court lourde

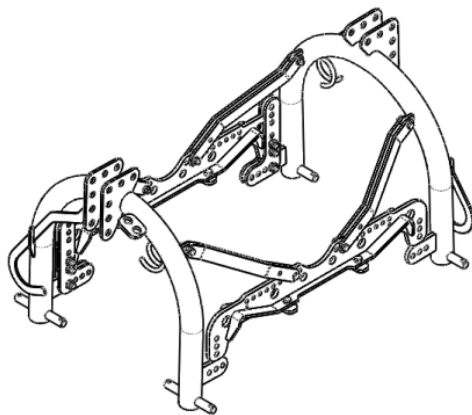
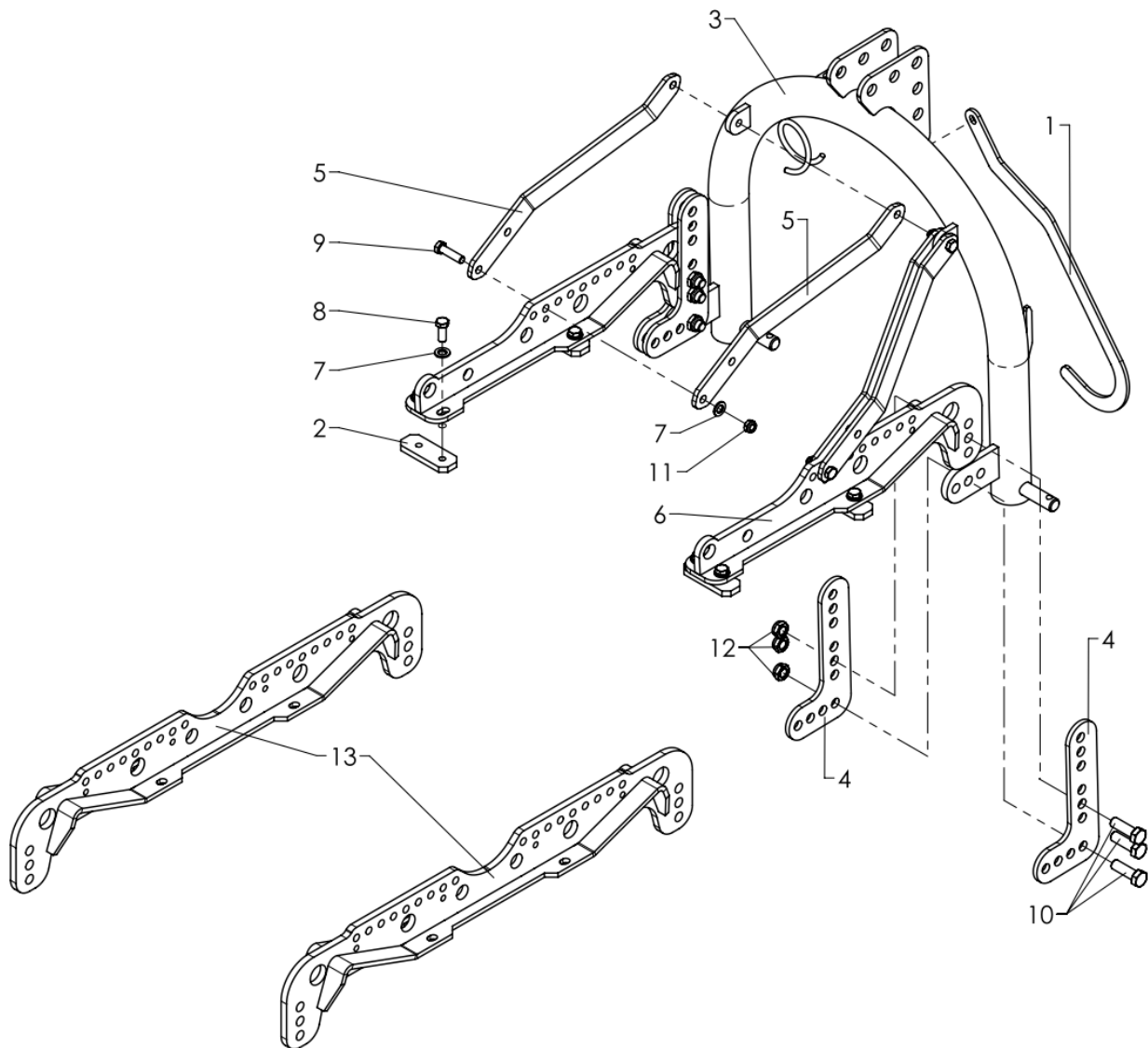

Dreipunkt Beidseitig Front/- Heckanbau  
Three-Point linkage for rear and front attachment  
Arceau à trois-point court

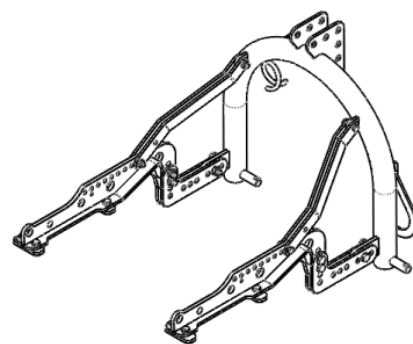

Dreipunkt Anbau Front oder Heck  
Three-Point linkage for rear or front attachment  
Arceau à trois-point court



POS.	Code	x	Bezeichnung	Description	Désignation	Info
1	M19291336	1	Gelenkwellenhaken	shaft hook	support cardan	
		2				
2	M26691319	4	Gewindeplatte	threaded plate	plaque fileté	
3	M32795032	1	Dreipunktbügel	three point frame	attelage trois-point	
		2				
4	M59091614	4	Dreipunktträger	support three point frame	support	
		8				
5	M59091629	4	Dreipunkthalter	support three point frame	support 3 points	
		8				
6	M59095100	2	Träger Dreipunkt	support three point frame	support	
7	M90125005	12	U-Scheibe	washer	rondelle	Ø13
		16				
8	M90933028	8	Skt.-Schraube	hexagon screw	vis à six pans creux	M12x30
9	M90933055	4	Skt.-Schraube	hexagon screw	vis à six pans creux	M12x45
		8				
10	M90933071	6	Skt.-Schraube	hexagon screw	vis à six pans creux	M16x50
		12				
11	M90985006	4	Polystopmutter	prevailing torque	écrou auto-freiné	M12
		8				
12	M90985008	6	Polystopmutter	prevailing torque	écrou auto-freiné	M16
		12				
13	M59095117	2	Träger Doppelbügel	support three point frame	support double	Beidseitiger Anbau for rear & front

Seitenverstellung / Side adjustment / déport latéral

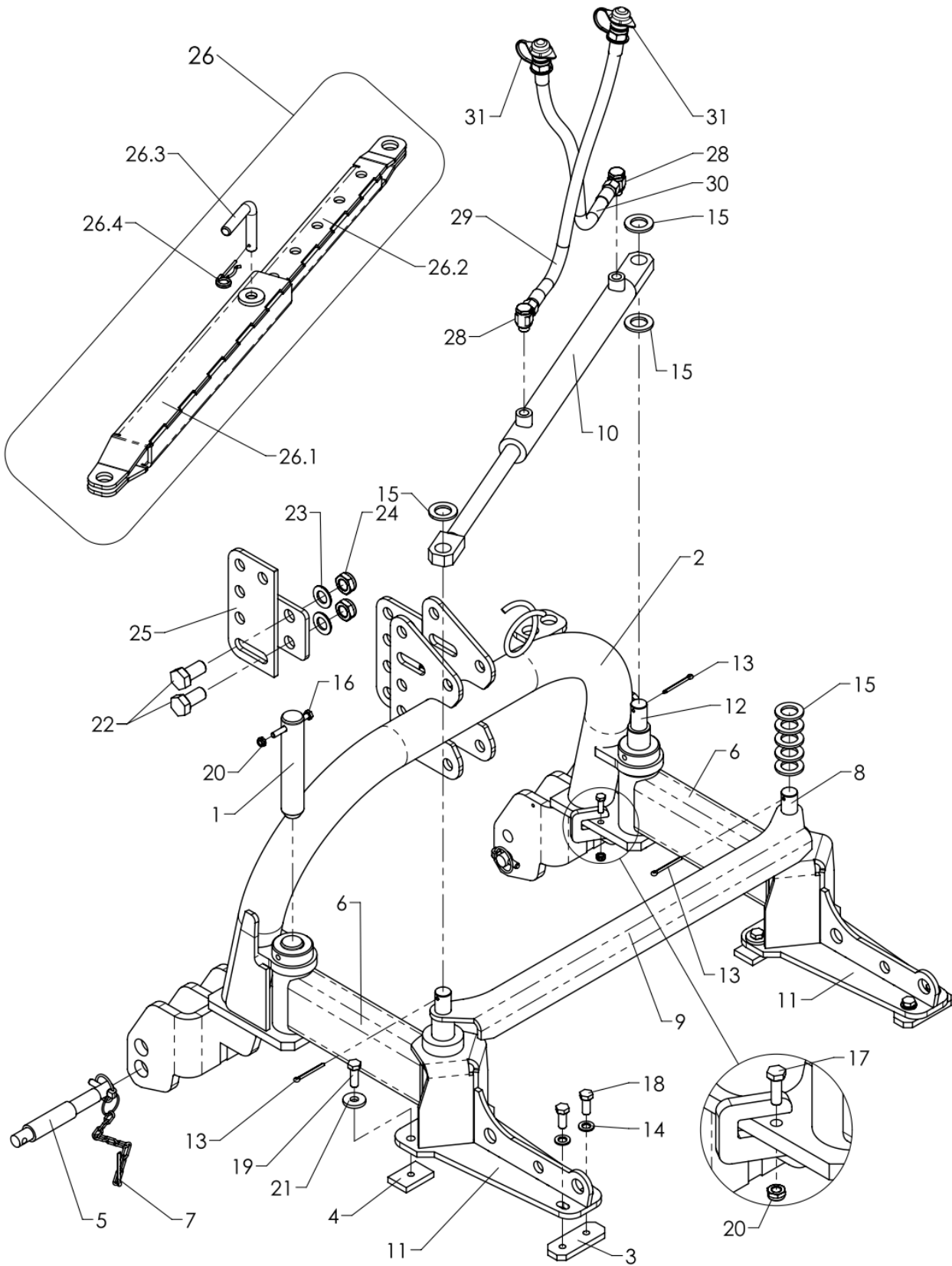

POS.	Code	x	Bezeichnung	Description	Désignation	Info
1	M18591395	1	Bolzen	bolt	boulon	
2	M18595801	1	Dreipunktbugel	three point frame	attelage trois point	
3	M26691319	2	Gewindeplatte	threaded plate	plaque fileté	2xM12
4	M26691489	4	Gewindeplatte	threaded plate	plaque fileté	1xM12
5	M32591446	2	Aufnahmebolzen	bolt	cheville	
6	M33195019	2	Verstellarm	adjusting arm	bras mobile	
7	M52195107	2	Kette	chain	chaîne	
8	M59091603	2	Bolzen	bolt	boulon	
9	M59091661	1	Dreipunktträger	support	support	
10	M59092662	1	Hydr.-Zylinder	hydraulic cylinder	vérin hydr.	
11	M59095119	2	Parallelogrammhalter	holder adjusting arm	support bras mobile	
12	M59095126	1	Bolzen	bolt	boulon	
13	M90094013	3	Splint	cotter pin	goupille	5x50
14	M90125005	4	U-Scheibe	washer	rondelle	Ø13
15	M90125010	8	U-Scheibe	washer	rondelle	Ø26
16	M90931044	3	Skt.-Schraube	hexagon screw	vis à six pans creux	M8x75
17	M90933012	1	Skt.-Schraube	hexagon screw	vis à six pans creux	M8x25
18	M90933028	4	Skt.-Schraube	hexagon screw	vis à six pans creux	M12x30
19	M90933029	4	Skt.-Schraube	hexagon screw	vis à six pans creux	M12x35
20	M90985004	4	Polystopmutter	prevailing torque	écrou auto-freiné	M8
21	M96340002	4	U-Scheibe	washer	rondelle	Ø13
22	M90933051		Skt.-Schraube	hexagon screw	vis à six pans creux	
23	M90125009		U-Scheibe	washer	rondelle	
24	M90985011		Polystopmutter	prevailing torque	écrou auto-freiné	
25	M18895028		Verlängerungsplatte kpl.	plate extension	Plaque rallonge	
26	M59095124		Seitenverstellung manuell	side adjustment manual	déport lateral manuel	
26.1	M59095123		Verstellrohr-02	tube-02	tube-02	
26.2	M59095122		Verstellrohr-01	tube-01	tube-01	
26.3	M52191308		Stecker	plug-in bolt	prise	
26.4	M81000202		Federstecker	spring cotter	fiche ressort	
27	M82100050		Schwenkverschr.	swivel fitting	raccord orientable	
28	M82101025		HD-Schlauch	hydraulic hose	flexible hydraulique	
29	M82101016		HD-Schlauch	hydraulic hose	flexible hydraulique	
30	M82008070		Kupplungsstecker mit Staubsch.	coupling plug	Prise avec bouchon	

Antrieb Nieder / Drive low / Entraînement à bas: 540 1/min & 1000 1/min

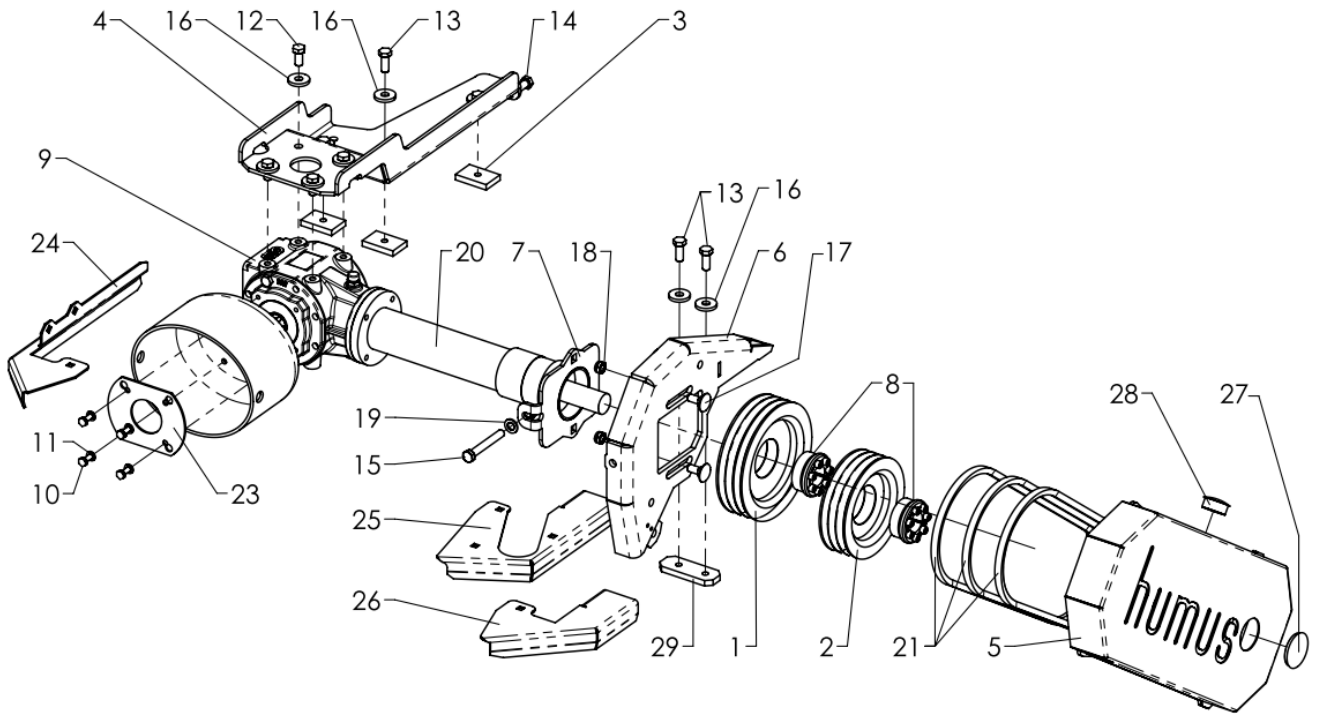

POS.	Code	Type	x	Bezeichnung	Description	Désignation	Info
1	M26691767		1	Riemenscheibe	v-belt pulley	poulie	
2	M26691769		1	Riemenscheibe	v-belt pulley	poulie	
3	M26691489		3	Gewindeplatte	threaded plate	plaque fileté	1 x M12
4	M59091630		1	Getriebehalter	support gear	support	
5	M59095111		1	Keilriemenschutz	V-belt cover	Couvercle de courroie trapezoidale	
6	M59095114		1	Seitenteil Nieder	side section	élément latéral	
7	M59095113		1	Getriebehalter	support gear	support	
8	M80013019		2	Spannsatz	clamp	fixation poulie	
9	M80014713		1	Getriebe	gearbox	transmission	540 1/min
	M80014714			Getriebe	gearbox	transmission	1000 1/min
10	M90933011		4	Skt.-Schraube	hexagon screw	vis à six pans creux	M8x20
11	M90125003		4	U-Scheibe	washer	rondelle	8,4
12	M90933027		4	Skt.-Schraube	hexagon screw	vis à six pans creux	M12x25
13	M90933028		3	Skt.-Schraube	hexagon screw	vis à six pans creux	M12x30
14	M90933031		1	Skt.-Schraube	hexagon screw	vis à six pans creux	M8x20
15	M90933036		1	Skt.-Schraube	hexagon screw	vis à six pans creux	M12x90
16	M96340002		7	U-Scheibe	washer	rondelle	Ø13
17	M90603017		2	Flachrundschrabe	carriage bolt	vis à tête bombée	M12x30
18	M90985006		2	Polystopmutter	prevailing torque	écrou auto-freiné	M12
19	M90125005		1	U-Scheibe	washer	rondelle	Ø13
20	M80014121	<b>85 95</b>	1	Verlängerung	extension	allongement	L = 400 mm
	M80014120	<b>105 115</b>	1	Verlängerung	extension	allongement	L = 500 mm
	M80014119	<b>125 135 145</b>	1	Verlängerung	extension	allongement	L = 615 mm
21	M80007015		3	Keilriemen	v-belt	courroie	
22	M52291325		1	Schutztopf	protective cover	bol de protection	
23	M52491333		1	Halterblech	holder	support	
24	M59091654		1	Anfahrerschutz rechts	column guard right	protection pied d'échelle droit	
25	M59091671	<b>85 95 105 115</b>	1	Anfahrerschutz links kurz	column guard left	protection pied d'échelle gauche	
26	M59091627	<b>125 135 145</b>	1				
27	M84300004		1	Kunststoffstopfen	plastic plug	bouchon plastique	Ø 55,5
28	M84300013		1	Kunststoffstopfen	plastic plug	bouchon plastique	Ø 39,5
29	M26691319		1	Gewindeplatte	threaded plate	plaque fileté	2 x M12

Antrieb Hoch / Drive / Entraînement à haut: 540 1/min & 1000 1/min

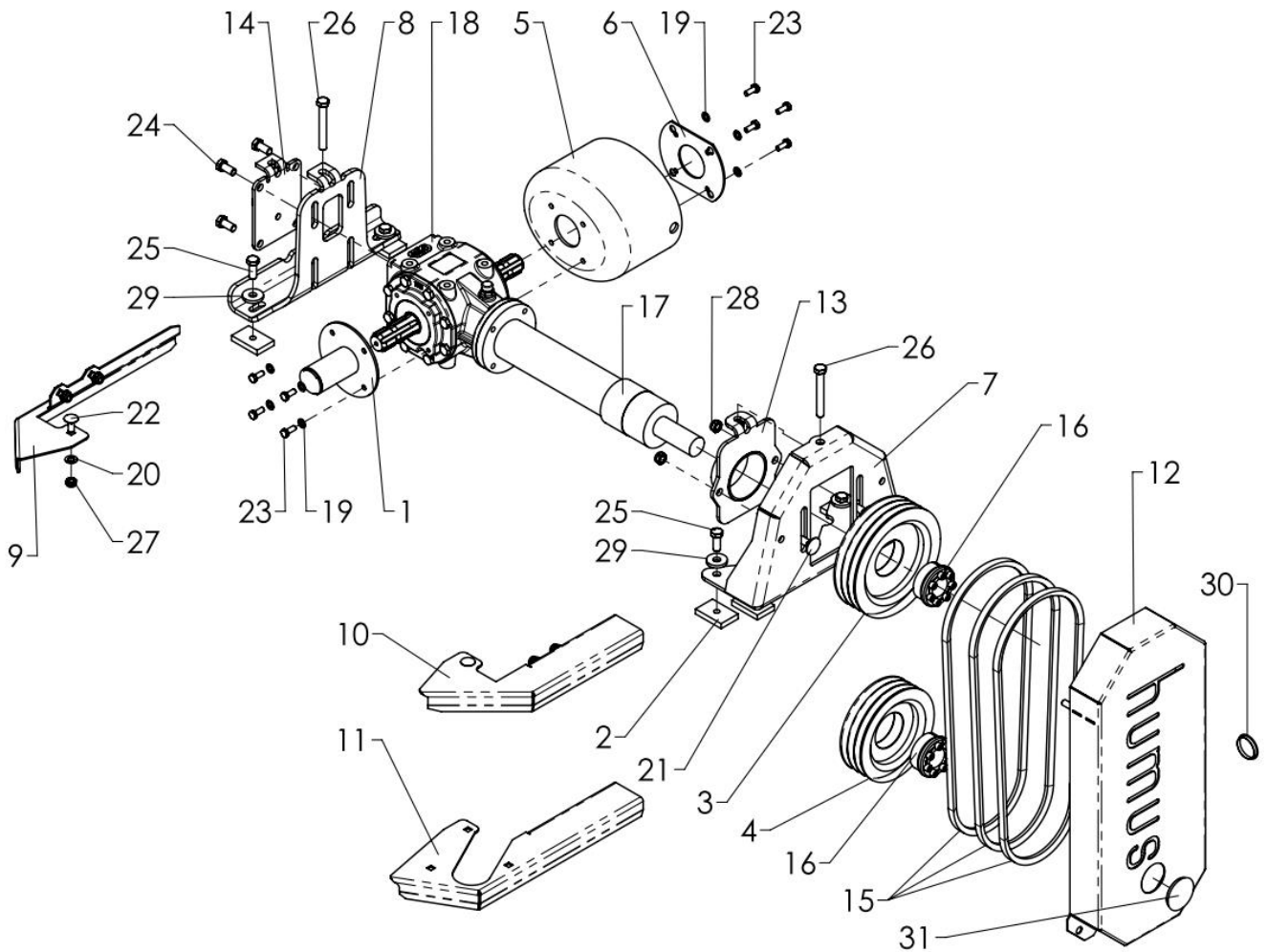

POS.	Code	Type	x	Bezeichnung	Description	Désignation	Info
1	M17795011		1	Keilwellenschutz	cover	protection	
2	M26691489			Gewindeplatte	threaded plate	plaque filetée	1 x M12
	M26691319	2 x M12					
3	M26691767		1	Riemenscheibe	v-belt pulley	poulie	
4	M26691769		1	Riemenscheibe	v-belt pulley	poulie	
5	M52291325		1	Schutztopf	protective cover	bol de protection	
6	M52491333		1	Halterblech	holder	support	
7	M59091620		1	Seitenteil	side section	élément latéral	
8	M59091621		1	Getriebehälter	support gear	support	
9	M59091654		1	Anfahrerschutz rechts	column guard right	protection pied d'échelle droit	
10	M59091656	<b>125 - 145</b>	1	Anfahrerschutz links lang	column guard left	protection pied d'échelle gauche	
11	M59091669	<b>85 - 115</b>	1				
12	M59095111		1	Keilriemenschutz	V-belt cover	Couvercle de courroie trapezoidale	
13	M59095113		1	Getriebehälter	support	support	
14	M59095130		1	Spannlasche	clamping plate	élément de serrage	
15	M80007015		3	Keilriemen	v-belt	courroie	
16	M80013019		2	Spannsatz	clamp	fixation poulie	
17	M80014121		1	Verlängerung	extension	allongement	L = 400 mm
	M80014119	Verlängerung		extension	allongement	L = 615 mm	
	M80014120	Verlängerung		extension	allongement	L = 500 mm	
18	M80014722		1	Getriebe	gearbox	transmission	540 1/min
	M80014714	Getriebe		gearbox	transmission	1000 1/min	
	M80014728		1	Getriebe mit Doppelfreilauf	gearbox with idle run	transmission avec roue libre	540 1/min
	M80014729	1000 1/min					
19	M90125003		8	U-Scheibe	washer	rondelle	Ø8,4
20	M90125004		6	U-Scheibe	washer	rondelle	Ø11
21	M90603017		2	Flachrundschraube	carriage bolt	vis à tête bombée	M12x30
22	M90603020		6	Flachrundschraube	carriage bolt	vis à tête bombée	M10x25
23	M90933011		8	Skt.-Schraube	hexagon screw	vis à six pans creux	M8x20
24	M90933027		4	Skt.-Schraube	hexagon screw	vis à six pans creux	M12x25
25	M90933028		6	Skt.-Schraube	hexagon screw	vis à six pans creux	M12x30
26	M90933036		2	Skt.-Schraube	hexagon screw	vis à six pans creux	M12x90
27	M90985005		6	Polystopmutter	prevailing torque	écrou auto-freiné	M10
28	M90985006		2	Polystopmutter	prevailing torque	écrou auto-freiné	M12
29	M96340002		6	U-Scheibe	washer	rondelle	Ø13
30	M84300013		1	Kunststoffstopfen	plastic plug	bouchon plastique	Ø 39,5
31	M84300004		1	Kunststoffstopfen	plastic plug	bouchon plastique	Ø 55,5

Rotorwelle/ Rotor shaft/ Axe batteur : SF; SK; Universal

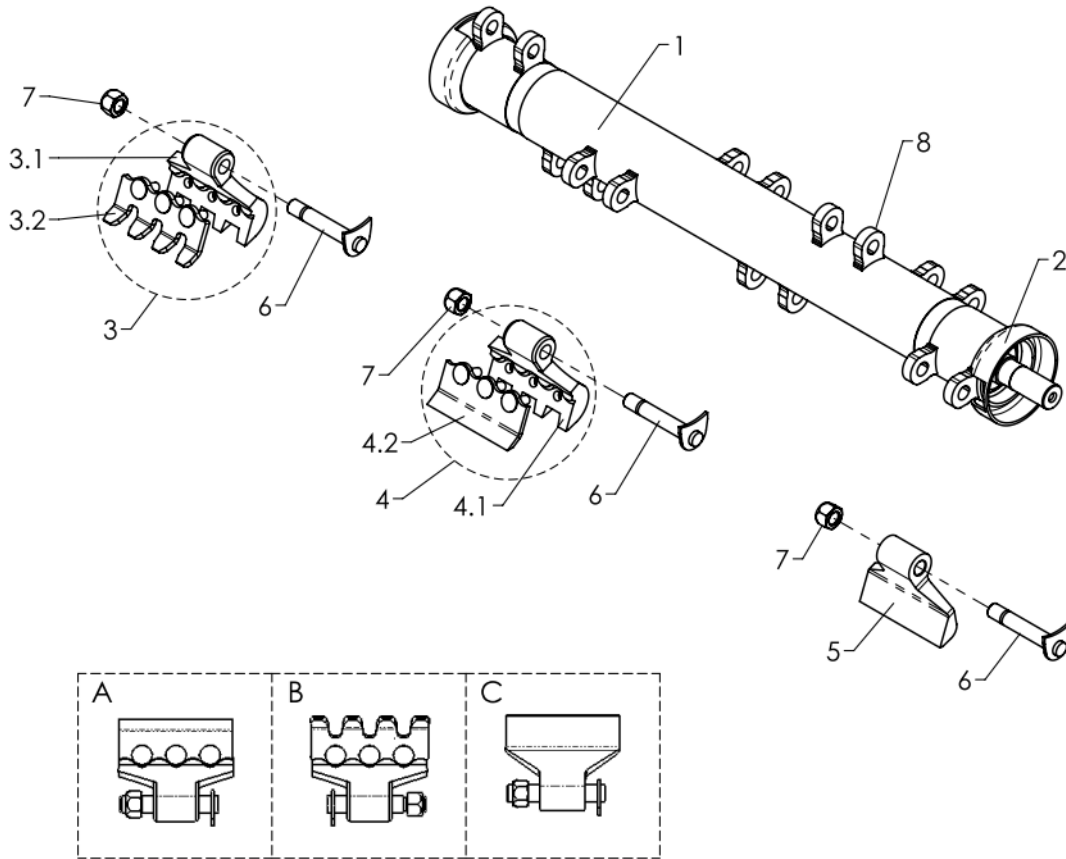



POS.	Code	Bezeichnung	Description	Désignation	Type
A	M59095115	System Feinschnittklinge Satz	club fail SF Set	mardeaux SF Set	SF
B	M59095215	System Krallenklinge Satz	club fail SK Set	mardeaux SK Set	SK
C	M59095415	Universalschlegel Satz	Universal club Set	Mardeaux universel Set	Universal



POS.	Code	Type	x	Bezeichnung	Description	Désignation	Info		
1	M58995180	<b>85</b>	1	Rotorwelle	rotor shaft	arbre de rotor			
	M59195180	<b>95</b>							
	M59295180	<b>105</b>							
	M59395180	<b>115</b>							
	M59495180	<b>125</b>							
	M59695180	<b>135</b>							
	M59595180	<b>145</b>							
2	M59091373		2	Wickelschutz	anti wrap protection	protège palier			
3	M22495078	<b>85</b> <b>95</b> <b>105</b> <b>115</b> <b>125</b> <b>135</b> <b>145*</b>	8 8 8 8 10 10 10* 12*	System-Schlegel m. Krallenklinge	club fail SK	marteaux SK			
3.1	M22492403			System-Messerträger	flail holder SK	support de lame SK			
3.2	M22495086			System-Krallenklinge mit Schrauben und Muttern	blade SK	lame SK			
4	M22495079			System-Schlegel m. Feinschnittklinge	club fail SK	marteaux SK			
4.1	M22492403			System-Messerträger	flail holder SK	support de lame SK			
4.2	M22495087			System-Feinschnittklinge m. Schrauben u. Muttern	blade SK with screw & bolts	lame SK cpl			
5	M22491390			Universalschlegel	Universal club	Marteaux universel			
6	M22495014			Schlegelschraube	flail bolt	Axe marteau			
7	M90980603			Stovermutter	prevailing torque	écrou auto-freiné	M20		
8	M22491342			<b>85</b>	16	Anschweißauge	welding lug	oeillets à souder	
				<b>95</b>	16				
				<b>105</b>	16				
		<b>115</b>	16						
		<b>125</b>	20						
		<b>135</b>	20						
		<b>145*</b>	20* 24*						

**\*Anmerkung / Remark / Remarque**

		
WM 145	4 Achsen / axes 12 Schlegel / club / marteux	5 Achsen / axes 10 Schlegel / club / marteux

Schlegelwelle mit Lager / Rotor shaft cpl./ Axe batteur cpl.: SF; SK; Universal

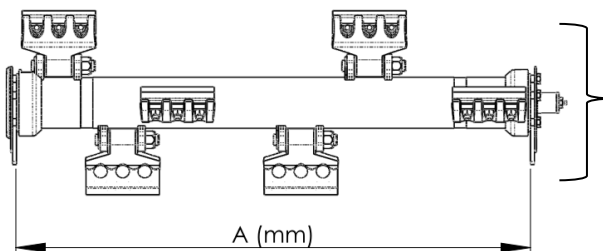
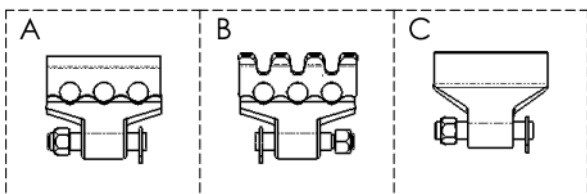
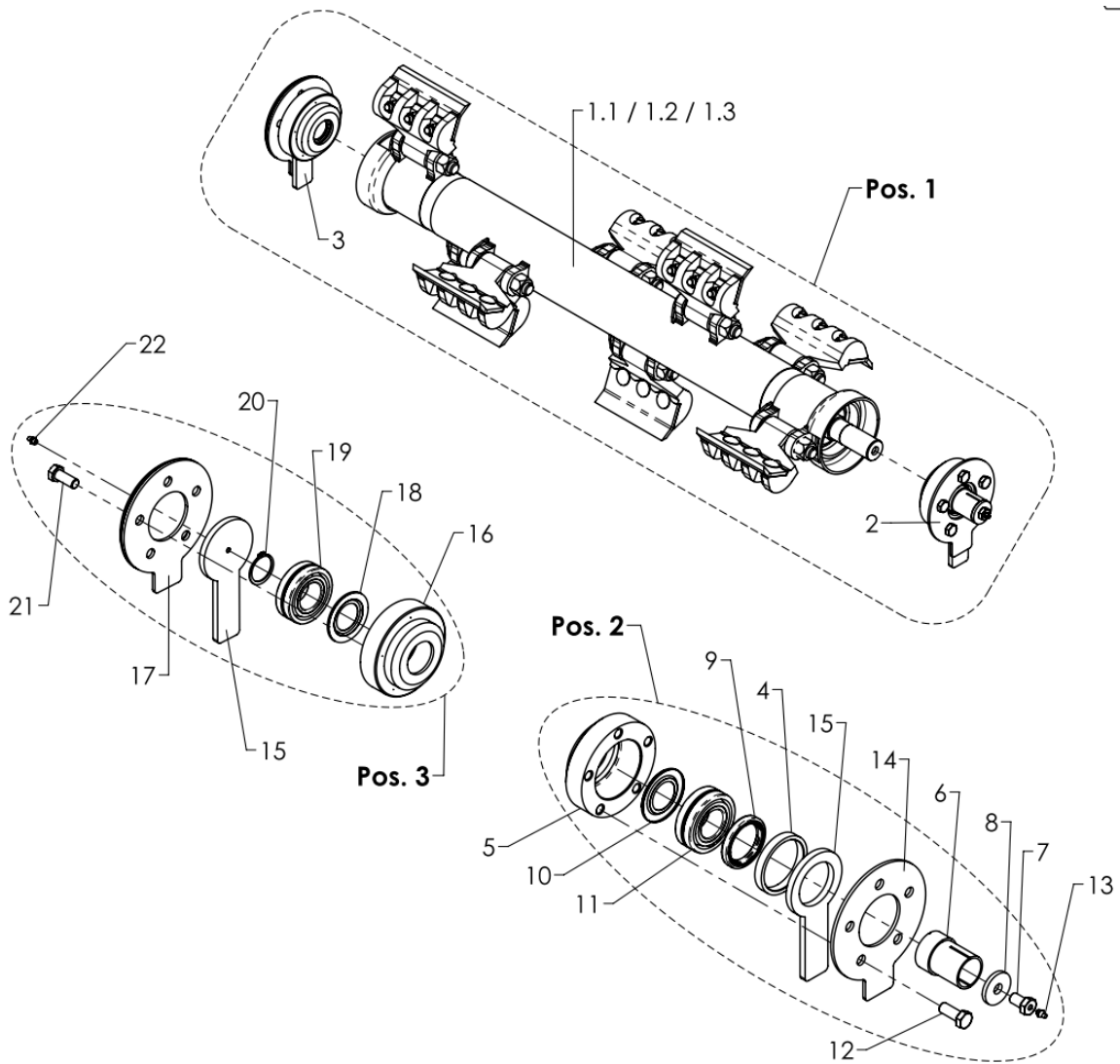

Pos. 1				
Pos.A SF	Pos. B SK	Pos. B Universal	Typ Type	A (mm)
M58995178	M58995278	M58995478	85	850
M59195178	M59195278	M59195478	95	950
M59295178	M59295278	M59295478	105	1050
M59395178	M59395278	M59395478	115	1150
M59495178	M59495278	M59495478	125	1250
M59595178	M59595278	M59595478	135	1350
M59695178	M59695278	M59695478	145	1450

POS.	Code	Type	x	Bezeichnung	Description	Désignation	Info
1.1	M58995181	<b>85</b>		Schlegelwelle m. Schlegel SF	rotor shaft SF	axe batteur SF	
	M59195181	<b>95</b>					
	M59295181	<b>105</b>					
	M59395181	<b>115</b>					
	M59495181	<b>125</b>					
	M59695181	<b>135</b>					
	M59595181	<b>145</b>					
1.2	M58995281	<b>85</b>		Schlegelwelle m. Schlegel SK	rotor shaft SK	axe batteur SK	
	M59195281	<b>95</b>					
	M59295281	<b>105</b>					
	M59395281	<b>115</b>					
	M59495281	<b>125</b>					
	M59695281	<b>135</b>					
	M59595281	<b>145</b>					
1.3	M58995481	<b>85</b>		Schlegelwelle m. Universalschlegel	rotor shaft Universal	axe batteur Universal	
	M59195481	<b>95</b>					
	M59295481	<b>105</b>					
	M59395481	<b>115</b>					
	M59495481	<b>125</b>					
	M59695481	<b>135</b>					
	M59595481	<b>145</b>					
2	M59095105		1	Festlager links kpl.	bearing case fixed	logement de palier glissant	
3	M59095116		1	Lagerung rechts kpl.	bearing RH cpl.	roulement droite cpl.	
<b>Pos. 2</b>							
4	M59091633		1	Tragring	ring	collier	
5	M59091634		1	Lagergehäuse fest	bearing case	logement de	
6	M59091638		1	Klemmhülse	clamping sleeve	Bague de serrage	
7	M59091640		1	Schmiernippel- schraube	hex screw for grease nipple	vis à six pans graisseur	
8	M59091641		1	Scheibe	disc	disque	
9	M83000010		1	Simmerring	retaining ring	bague d'étanchéité	
10	M83002007		1	Nilosring	NILOS ring	NILOS rondelle	
11	M89022207		1	Pendelrollenlager	bearing	roulement	
12	M90933906		5	Skt.-Schraube	hexagon screw	vis à six pans creux	
13	M97141201		1	Schmiernippel	grease nipple	graisseur	
14	M59091645		1	Deckel	cover	couvercle	
15	M59091608		1	Schutzblech	protection plate	protection	
<b>Pos. 3</b>							
15	M59091601		1	Schutzblech	protection plate	protection	
16	M59091636		1	Lagergehäuse lose	bearing case	logement de	
17	M59095109		1	Lagerdeckel	bearing cover	couvercle de palier	
18	M83002007		1	Nilosring	NILOS ring	NILOS rondelle	
19	M89022207		1	Pendelrollenlager	bearing	roulement	
20	M90471013		1	Seegerring	retaining ring	circlip	
21	M90933906		5	Skt.-Schraube	hexagon screw	vis à six pans creux	
22	M97141201		1	Schmiernippel	grease nipple	graisseur	

Klingenmesserwelle kpl. m. Lager / Rotor shaft, Y-type flails with bearings /  
Rotor porte couteaux Y avec palier

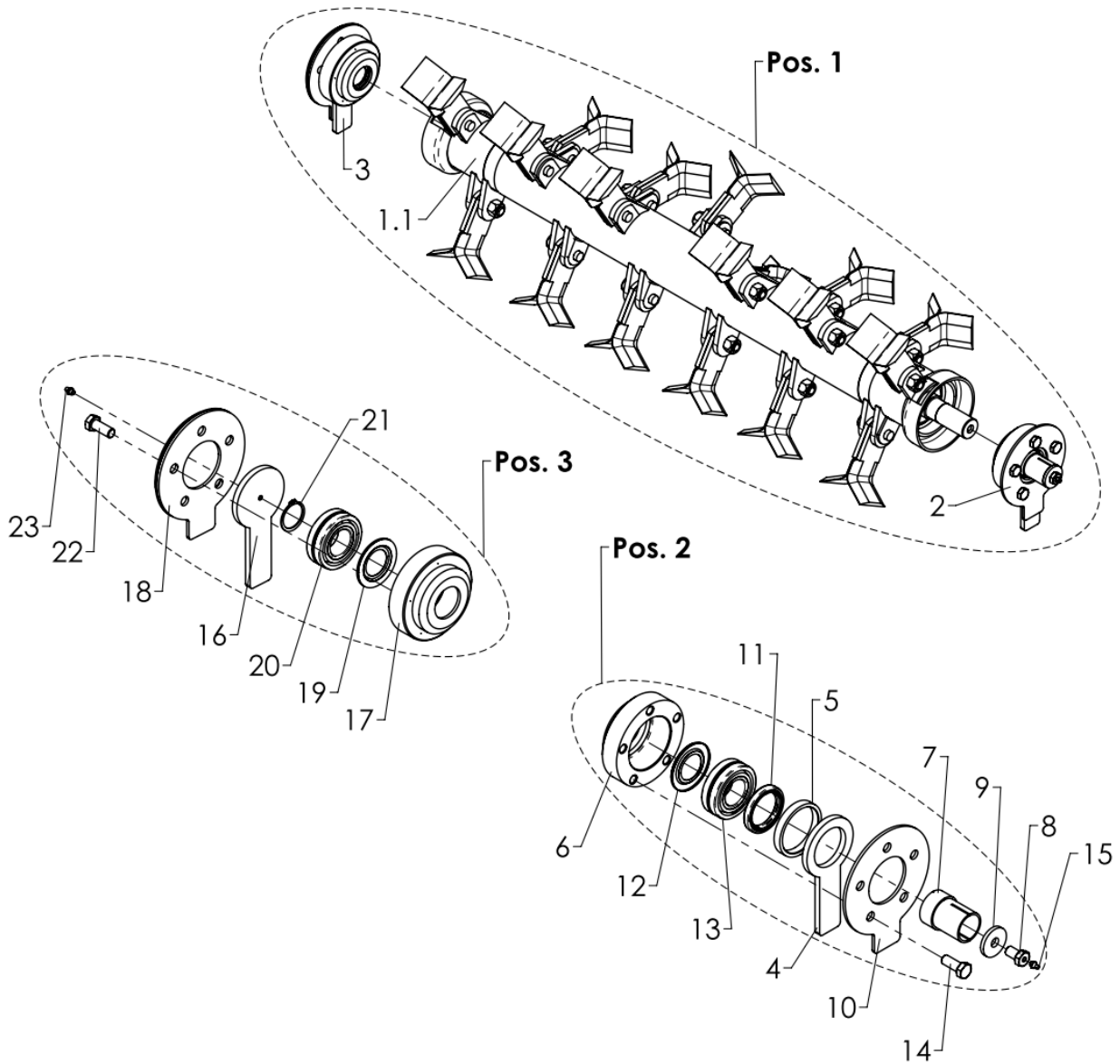

POS.	Code	Type	X	Bezeichnung	Description	Désignation	Info
<b>Pos. 1</b>							
	M58995578	<b>85</b>		Klingenmesserwelle kpl. mit Lager	Rotor shaft, Y-type flails with bearings	Axe de batteur cpl. avec roulement	
	M59195578	<b>95</b>					
	M59295578	<b>105</b>					
	M59395578	<b>115</b>					
	M59495578	<b>125</b>					
	M59695578	<b>135</b>					
	M59595578	<b>145</b>					
1.1	M58995581	<b>85</b>	1	Rotorwelle m. Klingenmesser	Rotor shaft with Y-type flails	axe avec couteaux Y	
	M59195581	<b>95</b>					
	M59295581	<b>105</b>					
	M59395581	<b>115</b>					
	M59495581	<b>125</b>					
	M59695581	<b>135</b>					
	M59595581	<b>145</b>					
2	M59095105		1	Festlager links kpl.	bearing case fixed	logement de palier glissant	
3	M59095116		1	Lagerung rechts kpl.	bearing RH cpl.	roulement droite cpl.	
<b>Pos. 2</b>							
4	M59091608			Schutzblech	protection plate	protection	
5	M59091633		1	Tragrings	ring	collier	
6	M59091634		1	Lagergehäuse fest	bearing case fixed	logement de palier fixe	
7	M59091638		1	Klemmhülse	clamping sleeve	machon de serrage	
8	M59091640		1	Schmiernippel- schraube	hex screw for grease nipple	vis de graissage	
9	M59091641		1	Scheibe	disc	disque	
10	M59091645			Deckel	cover	couvercle	
11	M83000010		1	Simmerring	retaining ring	bague d'étanchéité	
12	M83002007		1	Nilosring	NILOS ring	NILOS rondelle	
13	M89022207		1	Pendelrollenlager	bearing	roulement	
14	M90933906		5	Skt.-Schraube	hexagon screw	vis à six pans	
15	M97141201		1	Schmiernippel	grease nipple	graisseur	
<b>Pos. 3</b>							
16	M59091601		1	Schutzblech	protection plate	protection	
17	M59091636		1	Lagergehäuse lose	bearing case fixed	logement de palier fixe	
18	M59095109		1	Lagerdeckel	bearing cover	couvercle de palier	
19	M83002007		1	Nilosring	NILOS ring	NILOS rondelle	
20	M89022207		1	Pendelrollenlager	bearing	roulement	
21	M90471013		1	Seegerring	retaining ring	circlip	
22	M90933906		5	Skt.-Schraube	hexagon screw	vis à six pans	
23	M97141201		1	Schmiernippel	grease nipple	graisseur	

Klingenmesserwelle / Rotor shaft, Y-type flails / Rotor porte couteaux Y

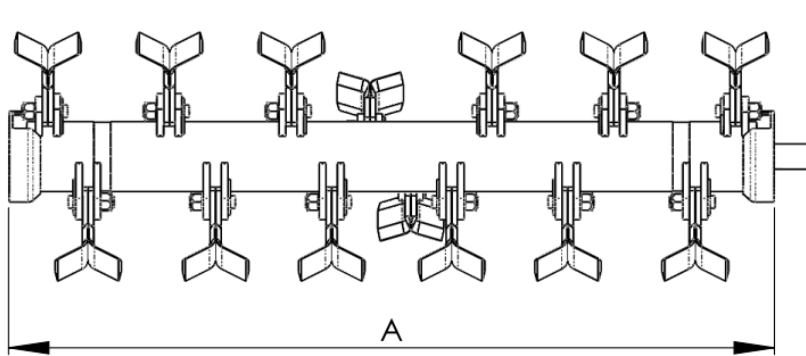
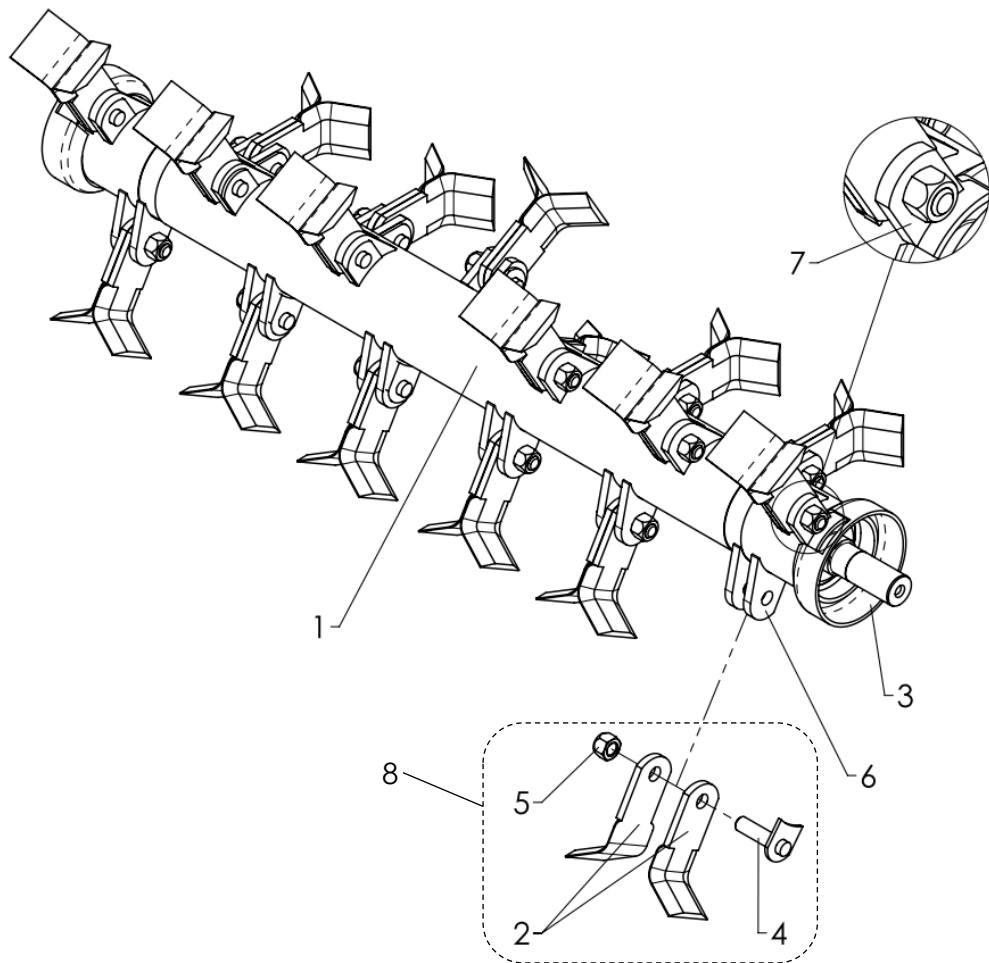

	Typ	A (mm)
M58995581	85	840
M59195581	95	940
M59295581	105	1040
M59395581	115	1140
M59495581	125	1240
M59595581	135	1340
M59695581	145	1440

POS.	Code	Type	x	Bezeichnung	Description	Désignation	Info
1	M58995580	<b>85</b>	1	Klingenmesserwelle	Rotor shaft	Rotor porte couteaux	
	M59195580	<b>95</b>					
	M59295580	<b>105</b>					
	M59395580	<b>115</b>					
	M59495580	<b>125</b>					
	M59695580	<b>135</b>					
	M59695580	<b>145</b>					
2	M22492376	<b>85</b>	24	Klingenmesser 8mm	Y-type flails 8mm	couteaux Y 8mm	
		<b>95</b>	28				
		<b>105</b>	30				
		<b>115</b>	36				
		<b>125</b>	36				
		<b>135</b>	42				
		<b>145</b>	48				
3	M59091373		2	Wickelschutz	anti wrap protection	protège palier	
4	M59095075			Messerschraube	flail screw	vis de couteaux Y	
5	M90980607			Stovermutter	prevailing torque	écrou auto-freine	
6	M59091374			Anschweißlappen	welding lug	oeillets à souder	
7	M59091375		2	Anschweißlappen	welding lug	oeillets à souder	
8	M59095135	<b>85</b>	12	Klingenmesser mit Schraube & Mutter	Y-type flails with screw & bolts	couteaux Y 8mm avec	
		<b>95</b>	14				
		<b>105</b>	15				
		<b>115</b>	18				
		<b>125</b>	18				
		<b>135</b>	21				
		<b>145</b>	24				

Hinweis:            Type entspricht Arbeitsbreite !  
Remark:            Type is equivalent to working width !  
Remarque:        Type largeur de travail !

Laufwalze / roller / rouleau stabilisateur

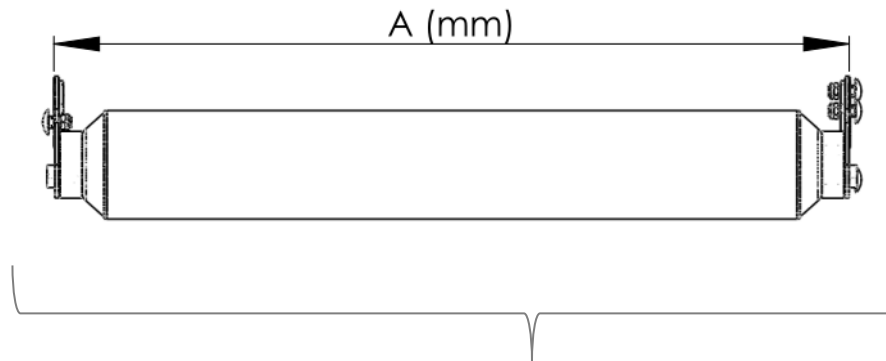

	Typ	A (mm)
M58995120	85	850
M59195120	95	950
M59295120	105	1050
M59395120	115	1150
M59495120	125	1250
M59695120	135	1350
M59595120	145	1450

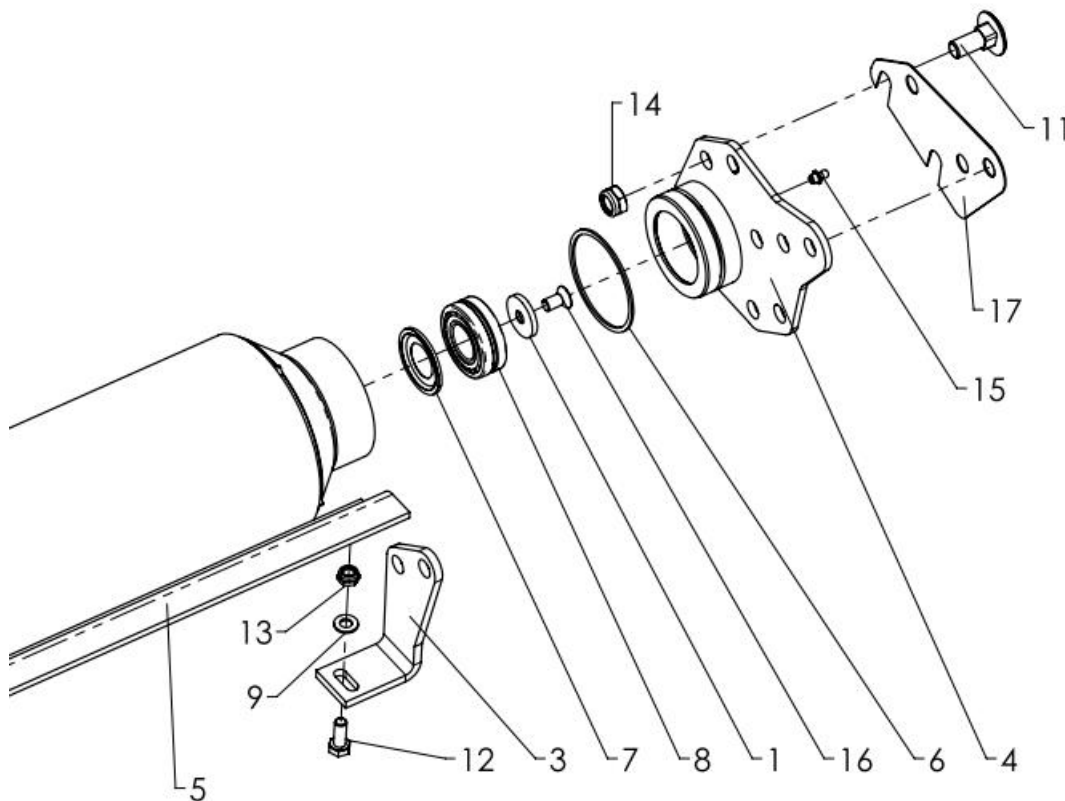



POS.	Code	Type	x	Bezeichnung	Description	Désignation	Info
1	M26691401		2	Sicherungsscheibe	lock washer	rondelle d'arrêt	
2	M26895056	<b>85</b>	1	Laufwalze	roller	rouleau stabilisateur	
	M59195721	<b>95</b>					
	M26895065	<b>105</b>					
	M59395721	<b>115</b>					
	M26695065	<b>125</b>					
	M59695721	<b>135</b>					
3	M59091657		1	Abstreiferhalter links	support scraper left	support racleur gauche	
	M59091658			Abstreiferhalter rechts	support scraper rechts	support droit	
4	M59095104		2	Lagergehäuse	bearing case	logement de palier	
5	M58991411	<b>85</b>	1	Abstreifer	scraper	racleur	
	M59191411	<b>95</b>					
	M59291411	<b>105</b>					
	M59391411	<b>115</b>					
	M59491411	<b>125</b>					
	M59691411	<b>135</b>					
6	M81003207		2	Lamellen-Dichtring	gasket	bague d'étanchéité	
7	M83002008		2	Nilosring	NILOS ring	NILOS rondelle	
8	M89022205		2	Pendelrollenlager	bearing	roulement	
9	M90125003		2	U-Scheibe	washer	rondelle	8,4
10	M90603015		4	Flachrundschraube	carriage bolt	vis à tête bombée	M12x35
11	M90603017		2	Flachrundschraube	carriage bolt	vis à tête bombée	M12x30
12	M90933011		2	Skf.-Mutter	hex nut	écrou hexagonal	M8x20
13	M90985004		2	Polystopmutter	prevailing torque	écrou auto-freiné	M8
14	M90985006		6	Polystopmutter	prevailing torque	écrou auto-freiné	M12
15	M97141201		2	Schmiernippel	grease nipple	graisseur	
16	M97991003		2	Senkschraube	countersunk screw	vis a tête fraisée	M8x16
17	M59091668		2	Distanzblech	spacing layer	pièce filetée	optional/ optionel

Hinweis: Type entspricht Arbeitsbreite !  
 Remark: Type is equivalent to working width !  
 Remarque: Type largeur de travail !

Fallklappen / Guard shutter / Barrette de protection

### WM 85 -115

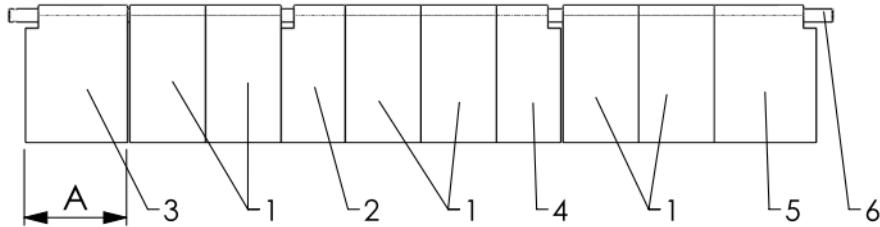

POS.	Code	Type	x	Bezeichnung	Description	Désignation	Info
1	M59091393	WM85	4	Fallklappe	guard shutter	barette de protection	A = 100 mm
		WM95	5				
		WM105	6				
		WM115	7				
2	M59091394		1	Fallklappe	guard shutter left	barette de protection	A = 85 mm
3	M59191394		1	Fallklappe	guard shutter	barette de protection	A = 135 mm
4	M59091395		1	Fallklapp	guard shutter	barette de protection	A = 85 mm
5	M59191395		1	Fallklappe	guard shutter	barette de protection	A = 135 mm
6	M59291405		1	Stange	support pole	selle	

### WM 125 - 145

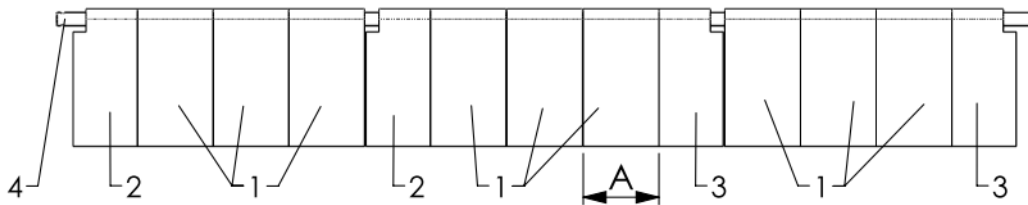

POS.	Code	Type	x	Bezeichnung	Description	Désignation	Info
1	M59091393	WM125	9	Fallklappe	guard shutter	barette de protection	A = 100 mm
		WM135	10				
		WM145	11				
2	M59091394		2	Fallklappe	guard shutter	barette de protection	A = 85 mm
3	M59091395		2	Fallklappe	guard shutter	barette de protection	A = 85 mm
4	M59491405		1	Stange	support pole	axe	



---

**Bestellformular / Spare parts order form / Commande pièces détachées**

per Fax unter

via fax at no. / par télécopie au no.

**+49 (0)7544 / 9506-43**

oder

per E-Mail an:

[guer@mabe-info.de](mailto:guer@mabe-info.de) / [gusejnow@mabe-info.de](mailto:gusejnow@mabe-info.de)

**nachfolgendes Bestellformular  
bitte als Kopiervorlage verwenden!**

The order form can be used as a master of copies!

Vous pouvez utiliser le formulaire comme copie!



von	Kunden Nr.:	Bestell-Nr.:
Firma		Besteller:
Straße		Telefon-Nr.:
		E-Mail:
Land / Plz. / Ort		Fax-Nr.:

abweichende Lieferadresse  Rechnungsadresse

Firma / Frau / Herr	
Straße, Hausnr.	
PLZ / Ort	

**Lieferung per:** Paketdienst  Express  Spedition  Selbstabholung   
 sonstiges  .....

Maschinentyp	Maschinen-Nr.:	Baujahr:	Besonderheit

Pos.	x/Menge	Code / Artikelnr.	Bezeichnung	Bemerkung
1				
2				
3				
4				
5				
6				
7				
8				
9				
10				

--	--	--

Datum: \_\_\_\_\_ Unterschrift: \_\_\_\_\_ Firmenstempel: \_\_\_\_\_

**Bestellungen per E-Mail an:**  
**per Fax an: +49 (0)7544 / 9506-43**



## Spare parts order to Maschinenfabrik Bermatingen GmbH & Co. KG

by	Customer number:	Order number:
Company:		Customer's Name:
		Phone:
Address:		Fax:
City, State, Zip:		

Delivery address as above  Bill to shipping address

Company / Ms., Mr.	
Address:	
City, State, postal code(zip):	

Shipment by: transport  express  Shipping company  pickup by customer   
 others  .....

machine type	machine number:	year of manufacture:	special feature:

Pos.	Quantity	x / Item number	Item description	Remark
1				
2				
3				
4				
5				
6				
7				
8				
9				
10				

Date: \_\_\_\_\_ Signature: \_\_\_\_\_ company stamp: \_\_\_\_\_

Order by E-Mail:  
 by fax: +49 (0)7544 / 9506-43



## Commande de pièces détachées à Maschinenfabrik Bermatingen GmbH & Co. KG

De	n° de client:	n° de commande:
Entreprise:		Mme./Melle/Mr.:
		n° téléphone:
Rue:		n° fax:
Code postal/ville:		

Adresse de livraison: voir ci-dessus  facture à adresse de livraison

Cie / Mme / Melle / Mr	
n° rue	
Code postal / ville	

Livraison par: transport  express  entreprise de  enlèvement par   
transport soi-même

Type de machine	n° machine:	année de construction:	Particularité:

Pos.	Quantité	x / n° pièce	désignation	remarque
1				
2				
3				
4				
5				
6				
7				
8				
9				
10				

Date:	Signature:	Cachet de l'entreprise:
<b>Commandez SVP par E-Mail:</b> par fax au n°: +49 (0)7544 / 9506-43		