

Publication 544
July 2008
Part No. 41571.44
Revision: 16.11.15



1.5M MULTICUT FLAILHEAD

54HP & 65HP MOTOR / QUAD DRIVE ROTOR
STANDARD ROLLER

Operator & Parts Manual

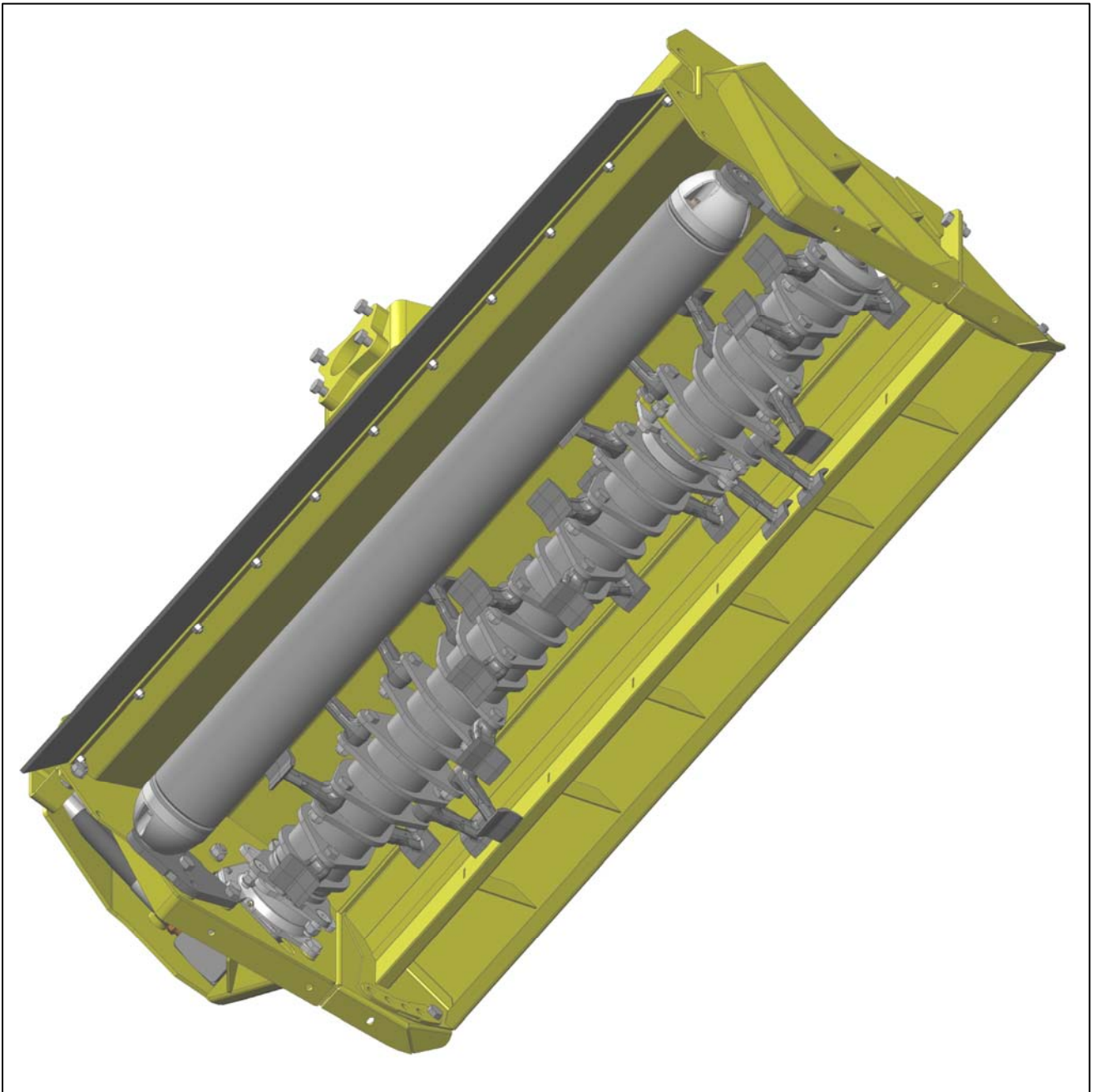

IMPORTANT

VERIFICATION OF WARRANTY REGISTRATION



DEALER WARRANTY INFORMATION & REGISTRATION VERIFICATION

It is imperative that the selling dealer registers this machine with McConnel Limited before delivery to the end user – failure to do so may affect the validity of the machine warranty.

To register machines go to the McConnel Limited web site at www.mcconnel.com, log onto 'Dealer Inside' and select the 'Machine Registration button' which can be found in the Service Section of the site. Confirm to the customer that the machine has been registered in the section below.

Should you experience any problems registering a machine in this manner please contact the McConnel Service Department on 01584 875848.

Registration Verification

Dealer Name:
Dealer Address:
Customer Name:
Date of Warranty Registration:/...../..... Dealer Signature:

NOTE TO CUSTOMER / OWNER

Please ensure that the above section above has been completed and signed by the selling dealer to verify that your machine has been registered with McConnel Limited.

IMPORTANT: During the initial 'bedding in' period of a new machine it is the customer's responsibility to regularly inspect all nuts, bolts and hose connections for tightness and re-tighten if required. New hydraulic connections occasionally weep small amounts of oil as the seals and joints settle in – where this occurs it can be cured by re-tightening the connection – *refer to torque settings chart below*. The tasks stated above should be performed on an hourly basis during the first day of work and at least daily thereafter as part of the machines general maintenance procedure.

TORQUE SETTINGS FOR HYDRAULIC FITTINGS

HYDRAULIC HOSE ENDS		
BSP	Setting	Metric
1/4"	18 Nm	19 mm
3/8"	31 Nm	22 mm
1/2"	49 Nm	27 mm
5/8"	60 Nm	30 mm
3/4"	80 Nm	32 mm
1"	125 Nm	41 mm
1.1/4"	190 Nm	50 mm
1.1/2"	250 Nm	55 mm
2"	420 Nm	70 mm

PORT ADAPTORS WITH BONDED SEALS		
BSP	Setting	Metric
1/4"	34 Nm	19 mm
3/8"	47 Nm	22 mm
1/2"	102 Nm	27 mm
5/8"	122 Nm	30 mm
3/4"	149 Nm	32 mm
1"	203 Nm	41 mm
1.1/4"	305 Nm	50 mm
1.1/2"	305 Nm	55 mm
2"	400 Nm	70 mm

WARRANTY POLICY

WARRANTY REGISTRATION

All machines must be registered, by the selling dealer with McConnel Ltd, before delivery to the end user. On receipt of the goods it is the buyer's responsibility to check that the Verification of Warranty Registration in the Operator's Manual has been completed by the selling dealer.

1. LIMITED WARRANTIES

- 1.01. *All machines supplied by McConnel Ltd are warranted to be free from defects in material and workmanship from the date of sale to the original purchaser for a period of 12 months, unless a different period is specified.*
- 1.02. *All spare parts supplied by McConnel Ltd and purchased by the end user are warranted to be free from defects in material and workmanship from the date of sale to the original purchaser for a period of 6 months. All parts warranty claims must be supported by a copy of the failed part invoice to the end user. We cannot consider claims for which sales invoices are not available.*
- 1.03. *The warranty offered by McConnel Ltd is limited to the making good by repair or replacement for the purchaser any part or parts found, upon examination at its factory, to be defective under normal use and service due to defects in material or workmanship. Returned parts must be complete and unexamined. Pack the component(s) carefully so that any transit damage is avoided. All ports on hydraulic items should be drained of oil and securely plugged to prevent seepage and foreign body ingress. Certain other components, electrical items for example, may require particular care when packing to avoid damage in transit.*
- 1.04. *This warranty does not extend to any product from which McConnel Ltd's serial number plate has been removed or altered.*
- 1.05. *This warranty does not apply to any part of the goods, which has been subjected to improper or abnormal use, negligence, alteration, modification, fitment of non-genuine parts, accident damage, or damage resulting from contact with overhead power lines, damage caused by foreign objects (e.g. stones, iron, material other than vegetation), failure due to lack of maintenance, use of incorrect oil or lubricants, contamination of the oil, or which has served its normal life. This warranty does not apply to any expendable items such as blades, belts, clutch linings, filter elements, flails, flap kits, skids, soil engaging parts, shields, guards, wear pads, pneumatic tyres or tracks.*
- 1.06. *Temporary repairs and consequential loss - i.e. oil, downtime and associated parts are specifically excluded from the warranty.*
- 1.07. *Warranty on hoses is limited to 12 months and does not include hoses which have suffered external damage. Only complete hoses may be returned under warranty, any which have been cut or repaired will be rejected.*
- 1.08. *Machines must be repaired immediately a problem arises. Continued use of the machine after a problem has occurred can result in further component failures, for which McConnel Ltd cannot be held liable, and may have safety implications.*
- 1.09. *If in exceptional circumstances a non McConnel Ltd part is used to effect a repair, warranty reimbursement will be at no more than McConnel Ltd's standard dealer cost for the genuine part.*
- 1.10. *Except as provided herein, no employee, agent, dealer or other person is authorised to give any warranties of any nature on behalf of McConnel Ltd.*
- 1.11. *For machine warranty periods in excess of 12 months the following additional exclusions shall apply:*
 - 1.11.1. *Hoses, exposed pipes and hydraulic tank breathers.*
 - 1.11.2. *Filters.*
 - 1.11.3. *Rubber mountings.*
 - 1.11.4. *External electric wiring.*
 - 1.11.5. *Bearings and seals.*

- 1.12. *All service work, particularly filter changes, must be carried out in accordance with the manufacturer's service schedule. Failure to comply will invalidate the warranty. In the event of a claim, proof of the service work being carried out may be required.*
- 1.13. *Repeat or additional repairs resulting from incorrect diagnosis or poor quality previous repair work are excluded from warranty.*

NB Warranty cover will be invalid if any non-genuine parts have been fitted or used. Use of non-genuine parts may seriously affect the machine's performance and safety. McConnel Ltd cannot be held responsible for any failures or safety implications that arise due to the use of non-genuine parts.

2. REMEDIES AND PROCEDURES

- 2.01. *The warranty is not effective unless the Selling Dealer registers the machine, via the McConnel Ltd web site and confirms the registration to the purchaser by completing the confirmation form in the operator's manual.*
- 2.02. *Any fault must be reported to an authorised McConnel Ltd dealer as soon as it occurs. Continued use of a machine, after a fault has occurred, can result in further component failure for which McConnel Ltd cannot be held liable.*
- 2.03. *Repairs should be undertaken within two days of the failure. Claims submitted for repairs undertaken more than 2 weeks after a failure has occurred, or 2 days after the parts were supplied will be rejected, unless the delay has been authorised by McConnel Ltd. Please note that failure by the customer to release the machine for repair will not be accepted as a reason for delay in repair or submitting warranty claims.*
- 2.04. *All claims must be submitted, by an authorised McConnel Ltd Service Dealer, within 30 days of the date of repair.*
- 2.05. *Following examination of the claim and parts, McConnel Ltd will pay, at their discretion, for any valid claim the invoiced cost of any parts supplied by McConnel Ltd and appropriate labour and mileage allowances if applicable.*
- 2.06. *The submission of a claim is not a guarantee of payment.*
- 2.07. *Any decision reached by McConnel Ltd is final.*

3. LIMITATION OF LIABILITY

- 3.01. *McConnel Ltd disclaims any express (except as set forth herein) and implied warranties with respect to the goods including, but not limited to, merchantability and fitness for a particular purpose.*
- 3.02. *McConnel Ltd makes no warranty as to the design, capability, capacity or suitability for use of the goods.*
- 3.03. *Except as provided herein, McConnel Ltd shall have no liability or responsibility to the purchaser or any other person or entity with respect to any liability, loss, or damage caused or alleged to be caused directly or indirectly by the goods including, but not limited to, any indirect, special, consequential, or incidental damages resulting from the use or operation of the goods or any breach of this warranty. Notwithstanding the above limitations and warranties, the manufacturer's liability hereunder for damages incurred by the purchaser or others shall not exceed the price of the goods.*
- 3.04. *No action arising out of any claimed breach of this warranty or transactions under this warranty may be brought more than one (1) year after the cause of the action has occurred.*

4. MISCELLANEOUS

- 4.01. *McConnel Ltd may waive compliance with any of the terms of this limited warranty, but no waiver of any terms shall be deemed to be a waiver of any other term.*
- 4.02. *If any provision of this limited warranty shall violate any applicable law and is held to be unenforceable, then the invalidity of such provision shall not invalidate any other provisions herein.*
- 4.03. *Applicable law may provide rights and benefits to the purchaser in addition to those provided herein.*



DECLARATION OF CONFORMITY

Conforming to EU Machinery Directive 2006/42/EC

We,

McCONNEL LIMITED, Temeside Works, Ludlow, Shropshire SY8 1JL, UK

Hereby declare that:

The Product; *Hydraulic Arm Mounted Flailhead*

Product Code; *BD12, BD16, F110, F112, F115, F012, F016*

Serial No. & Date Type

Manufactured in; *United Kingdom*

Complies with the required provisions of the Machinery Directive 2006/42/EC
The machinery directive is supported by the following harmonized standards;

- BS EN ISO 12100 (2010) Safety of machinery – General principles for design – Risk assessment and risk reduction.
- BS EN 349 (1993) + A1 (2008) Safety of machinery - Minimum distances to avoid the entrapment with human body parts.
- BS EN 953 (1997) + A1 (2009) Safety of machinery - Guards general requirements for the design and construction of fixed and movable guards.
- BS EN 4413 (2010) Hydraulic fluid power. Safety requirements for systems and their components.

McCONNEL LIMITED operates an ISO 9001:2008 quality management system, certificate number: FM25970.

This system is continually assessed by the;

British Standards Institution (BSI), Beech House, Milton Keynes, MK14 6ES, UK
BSI is accredited by UK Accreditation Service, accreditation number: UKAS 003.

The EC declaration only applies if the machine stated above is used in accordance with the operating instructions.

Signed *Responsible Person*
CHRISTIAN DAVIES on behalf of McCONNEL LIMITED

Status: *General Manager*

Date: *September 2015*

CONTENTS

Page No.

Operator Section

General Information	2
Safety Information	3
Pre-Operational Checks	7
Roller Positions	8
Flailhead Arrangement for Mowing	10
Flailhead Arrangement for Hedge Cutting	12
Hedgecutting Procedure	14
Flail Identification	15
Maintenance	16
Rotor Shaft Alignment	17

Parts Section

Casing Assembly	20
Motor Cover	21
Drive Assemblies	22
Quad Drive Assembly	24
Rotor Assemblies	25
Roller Assembly	30
Flap Kit (<i>Optional Extra</i>)	32
Skid Kit (<i>Optional Extra</i>)	33
Decal Kit	34

GENERAL INFORMATION

Always read this manual before fitting or operating the machine – whenever any doubt exists contact your dealer or the McConnel Service Department for advice and assistance.

Use only McConnel Genuine Service Parts on McConnel Equipment and Machines

DEFINITIONS – *The following definitions apply throughout this manual:*

WARNING

*An operating procedure, technique etc., which –
can result in personal injury or loss of life if not observed carefully.*

CAUTION

*An operating procedure, technique etc., which –
can result in damage to either machine or equipment if not observed carefully.*

NOTE

*An operating procedure, technique etc., which –
is considered essential to emphasis.*

LEFT AND RIGHT HAND

*This term is applicable to the machine when attached to the tractor and is viewed
from the rear – this also applies to tractor references.*

Note: The illustrations in this manual are for instructional purposes only and may on occasion not show some components in their entirety. In some instances an illustration may appear slightly different to that of your particular model but the general procedure will be the same. E&OA.

MACHINE & DEALER INFORMATION

Record the Serial Number of your machine on this page and always quote this number when ordering parts. Whenever information concerning the machine is requested remember also to state the make and model of tractor to which the machine is fitted.

Machine Serial Number:	Installation Date:
Machine Model details:	
Dealer Name:	
Dealer Address:	
Dealer Telephone No:	
Dealer Email Address:	



This machine has the potential to be extremely dangerous, in the wrong hands it can kill or maim. It is therefore imperative that both owner, and operator of this machine, read and understand the following section to ensure that they are fully aware of the dangers that do, or may exist, and their responsibilities surrounding the use and operation of the machine. The operator of this machine is responsible not only for their own safety but equally for the safety of others who may come into the close proximity of the machine, as the owner you are responsible for both.

When the machine is not in use the cutting head should be lowered to rest on the ground. In the event of a fault being detected with the machine's operation it should be stopped immediately and not used again until the fault has been corrected by a qualified technician.

POTENTIAL SIGNIFICANT DANGERS ASSOCIATED WITH THE USE OF THIS MACHINE:

- ▲ *Being hit by debris thrown by rotating components.*
- ▲ *Being hit by machine parts ejected through damage during use.*
- ▲ *Being caught on a rotating power take-off (PTO) shaft.*
- ▲ *Being caught in other moving parts i.e.: belts, pulleys and cutting heads.*
- ▲ *Electrocution from Overhead Power Lines (by contact with or 'flashover' from).*
- ▲ *Being hit by cutting heads or machine arms as they move.*
- ▲ *Becoming trapped between tractor and machine when hitching or unhitching.*
- ▲ *Tractor overbalancing when machine arm is extended.*
- ▲ *Injection of high-pressure oil from hydraulic hoses or couplings.*
- ▲ *Machine overbalancing when freestanding (out of use).*
- ▲ *Road traffic accidents due to collision or debris on the road.*

BEFORE USING THIS MACHINE YOU MUST:

- ▲ *Ensure you read all sections of the operator handbook.*
- ▲ *Ensure the operator is, or has been, properly trained to use the machine.*
- ▲ *Ensure the operator has been issued with and reads the operator handbook.*
- ▲ *Ensure the operator understands and follows the instructions in operator handbook.*
- ▲ *Ensure the tractor front, rear and side(s) are fitted with metal mesh or polycarbonate guards of suitable size and strength to protect the operator against thrown debris or parts.*
- ▲ *Ensure tractor guards are fitted correctly, are undamaged and kept properly maintained.*
- ▲ *Ensure that all machine guards are in position, are undamaged, and are kept maintained in accordance with the manufacturer's recommendations.*
- ▲ *Ensure flails and their fixings are of a type recommended by the manufacturer, are securely attached and that none are missing or damaged.*
- ▲ *Ensure hydraulic pipes are carefully and correctly routed to avoid damage by chaffing, stretching or pinching and that they are held in place with the correct fittings.*
- ▲ *Always follow the manufacturer's instructions for attachment and removal of the machine from the tractor.*
- ▲ *Check that the machine fittings and couplings are in good condition.*
- ▲ *Ensure the tractor meets the minimum weight recommendations of the machine's manufacturer and that ballast is used as necessary.*
- ▲ *Always inspect the work area thoroughly before starting to note obstacles and remove wire, bottles, cans and other debris.*
- ▲ *Use clear suitably sized warning signs to alert others to the nature of the machine working within that area. Signs should be placed at both ends of the work site. (It is recommended that signs used are of a size and type specified by the Department of Transport and positioned in accordance with their, and the Local Highways Authority, guidelines).*
- ▲ *Ensure the operator is protected from noise. Ear defenders should be worn and tractor cab doors and windows must be kept closed. Machine controls should be routed through proprietary openings in the cab to enable all windows to be shut fully.*
- ▲ *Always work at a safe speed taking account of the conditions i.e.: terrain, highway proximity and obstacles around and above the machine. Extra special attention should be applied to Overhead Power Lines. Some of our machines are capable of reach in excess of 8 metres (26 feet) this means they have the potential to well exceed, by possibly 3 metres (9' 9"), the lowest legal minimum height of 5.2 metres from the ground for 11,000 and 33,000 volt power lines. It cannot be stressed enough the dangers that surround this capability, it is therefore vital that the operator is fully aware of the maximum height and reach of the machine, and that they are fully conversant with all aspects regarding the safe minimum distances that apply when working with machines in close proximity to Power Lines. (Further information on this subject can be obtained from the Health & Safety Executive or your Local Power Company).*

- ▲ *Always disengage the machine, kill the tractor engine, remove and pocket the key before dismounting for any reason.*
- ▲ *Always clear up all debris left at the work area, it may cause hazard to others.*
- ▲ *Always ensure when you remove your machine from the tractor that it is left in a safe and stable position using the stands and props provided and secured if necessary.*

WHEN NOT TO USE THIS MACHINE:

- ▲ *Never attempt to use this machine if you have not been trained to do so.*
- ▲ *Never use a machine until you have read and understood the operator handbook, are familiar with it, and practiced the controls.*
- ▲ *Never use a machine that is poorly maintained.*
- ▲ *Never use a machine if guards are missing or damaged.*
- ▲ *Never use a machine on which the hydraulic system shows signs of wear or damage.*
- ▲ *Never fit, or use, a machine on a tractor that does not meet the manufacturer's minimum specification level.*
- ▲ *Never use a machine fitted to a tractor that does not have suitable front, rear and side(s) cab guarding made of metal mesh or polycarbonate.*
- ▲ *Never use the machine if the tractor cab guarding is damaged, deteriorating or badly fitted.*
- ▲ *Never turn a machine cutting head to an angle that causes debris to be ejected towards the cab.*
- ▲ *Never start or continue to work a machine if people are nearby or approaching - Stop and wait until they are at a safe distance before continuing. WARNING: Some Cutting Heads may continue to 'freewheel' for up to 40 seconds after being stopped.*
- ▲ *Never attempt to use a machine on materials in excess of its capability.*
- ▲ *Never use a machine to perform a task it has not been designed to do.*
- ▲ *Never operate the tractor or machine controls from any position other than from the driving seat, especially whilst hitching or unhitching the machine.*
- ▲ *Never carry out maintenance of a machine or a tractor whilst the engine is running – the engine should be switched off, the key removed and pocketed.*
- ▲ *Never leave a machine unattended in a raised position – it should be lowered to the ground in a safe position on a level firm site.*
- ▲ *Never leave a tractor with the key in or the engine running.*
- ▲ *Never carry out maintenance on any part or component of a machine that is raised unless that part or component has been properly substantially braced or supported.*
- ▲ *Never attempt to detect a hydraulic leak with your hand – use a piece of cardboard.*
- ▲ *Never allow children near to, or play on, a tractor or machine under any circumstances.*

ADDITIONAL SAFETY ADVICE

Training

Operators need to be competent and fully capable of operating this machine in a safe and efficient way prior to attempting to use it in any public place. We advise therefore that the prospective operator make use of relevant training courses available such as those run by the Agricultural Training Board, Agricultural Colleges, Dealers and McConnel.

Working in Public Places

When working in public places such as roadsides, consideration should be paid to others in the vicinity. Stop the machine immediately when pedestrians, cyclists and horse riders etc. pass. Restart only when they are at a distance that causes no risk to their safety.

Warning Signs

It is advisable that any working area be covered by suitable warning signs and statutory in public places. Signs should be highly visible and well placed in order to give clear advanced warning of the hazard. Contact the Department of Transport or your Local Highways Authority to obtain detailed information on this subject. The latter should be contacted prior to working on the public highway advising them of the time and location of the intended work asking what is required by way of signs and procedure. – ‘*Non-authorized placement of road signs may create offences under the Highways Act*’.

Suggested Warning Signs Required

“Road works ahead” warning sign with a supplementary **“Hedge cutting”** plate. **“For 1 mile”** or appropriate shorter distance may be added to the plate.

“Road narrows” warning sign with supplementary **“Single file traffic”** plate.

White on blue **“Keep right”** (*) arrow sign on rear of machine.

* Note – this applies to UK Market machines where traffic passes to the right of a machine working in the same direction as the traffic flow. The direction, use and colour of the arrow sign will depend on the country of use and the Local Highway Authorities regulations in the locality.

Use of Warning Signs

- ▲ On two-way roads one set of signs is needed facing traffic in each direction.
- ▲ Work should be within 1 mile of the signs.
- ▲ Work only when visibility is good and at times of low risk e.g.: NOT during ‘rush-hour’.
- ▲ Vehicles should have an amber-flashing beacon.
- ▲ Ideally, vehicles should be conspicuously coloured.
- ▲ Debris should be removed from the road and path as soon as practicable, and at regular intervals, wearing high visibility clothing and before removing the hazard warning signs.
- ▲ Collect all road signs promptly when the job is completed.

Although the information given here covers a wide range of safety subjects, it is impossible to predict every eventuality that can occur under differing circumstances whilst operating this machine. No advice given here can replace ‘good common sense’ and ‘total awareness’ at all times, but will go a long way towards the safe use of your McConnel machine.

PRE-OPERATIONAL CHECKS

Check all bolts are tight and that the torque figures are correct for the specific locations indicated below:

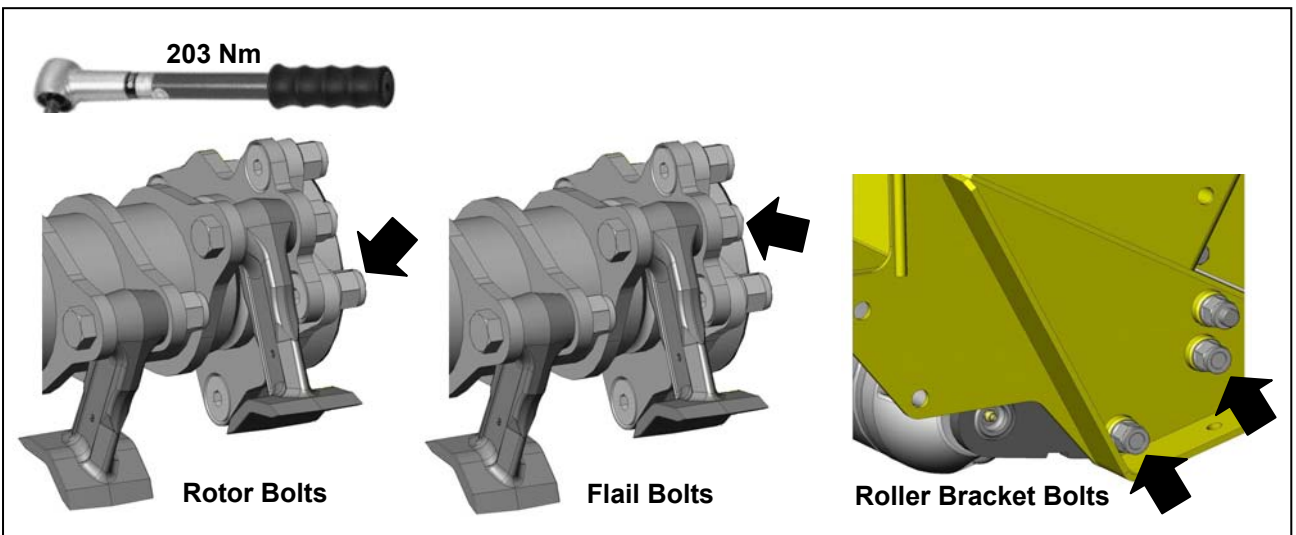
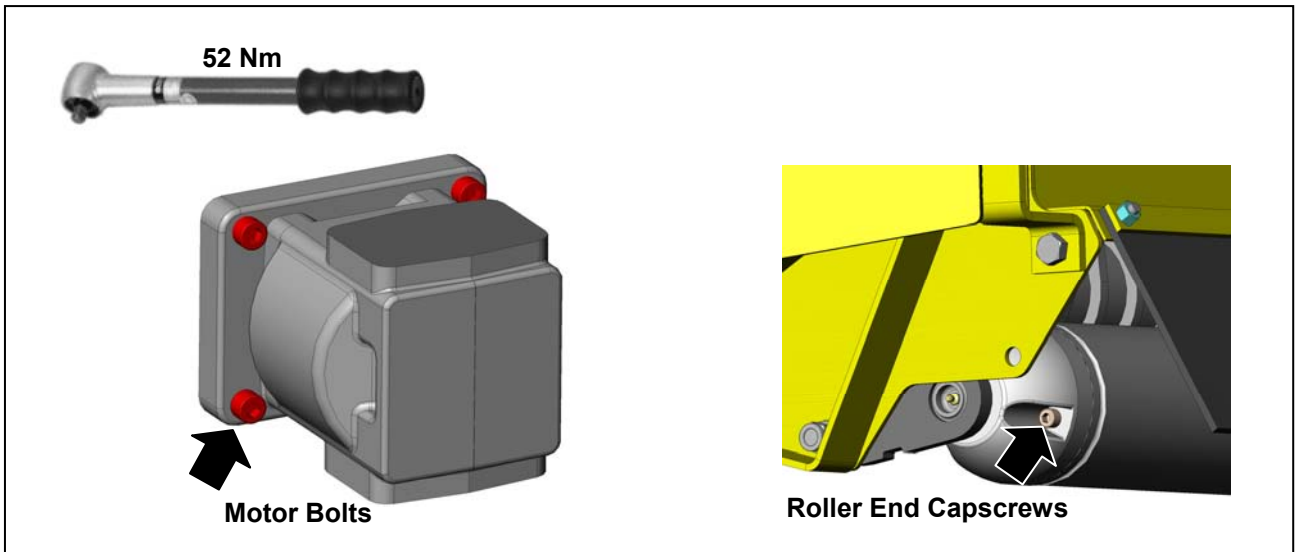

IMPORTANT

On the first day of use with a new flailhead, nuts should be checked for tightness every hour and retightened if required. Thereafter they should be checked on a daily basis prior to use of the machine.

Torque nuts to the settings stated above.

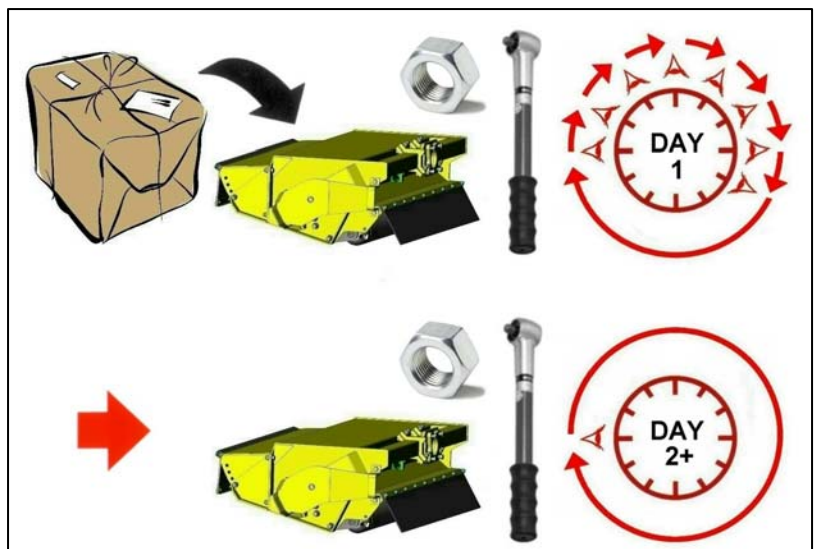

OPERATION

Material Thickness Limitations



Flailhead Rear Roller

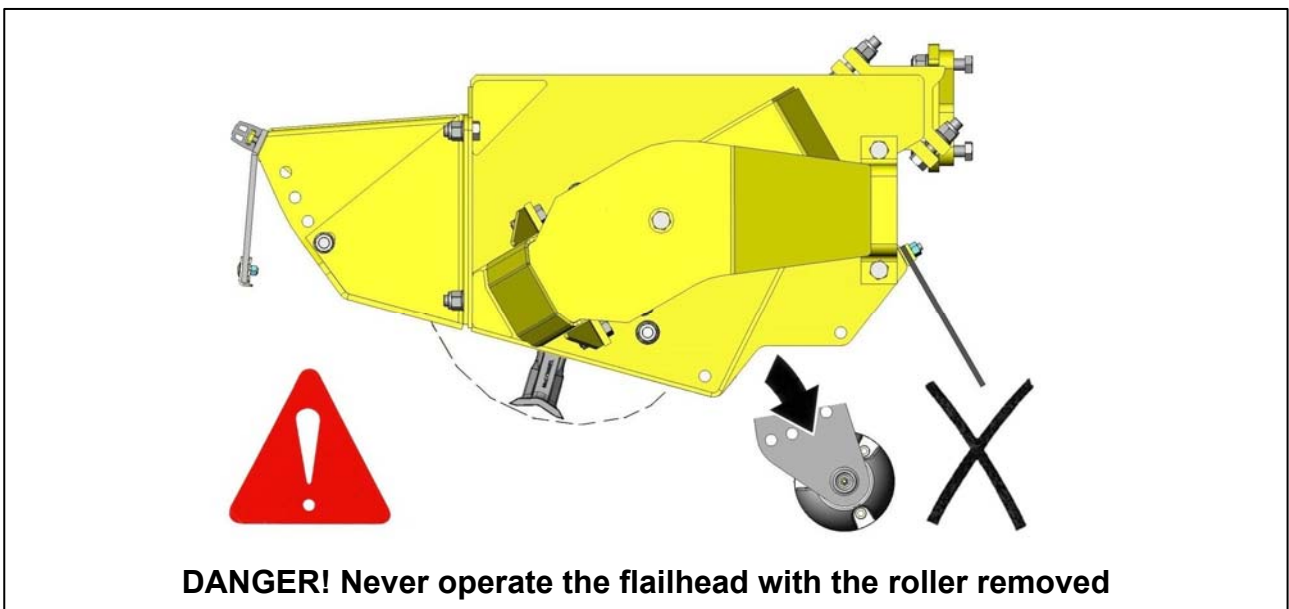

Roller Positions

The opposing pairs of roller brackets have been designed so they can be fitted on either side of the flailhead to provide 10 differing roller heights – 5 height settings in the standard mode and 5 when 'swapped over' into the alternate mode. Each mode provides 1 height setting for hedge cutting work where the roller is set above the cut and 4 for grass mowing where the roller is set below the cut – refer to the diagrams on the following page for specific details of the height settings.

WARNING!
Under no circumstances should the flail head be operated with the rear roller removed.

Use roller in position 1 for hedges and 2, 3, 4 or 5 for grass mowing ►

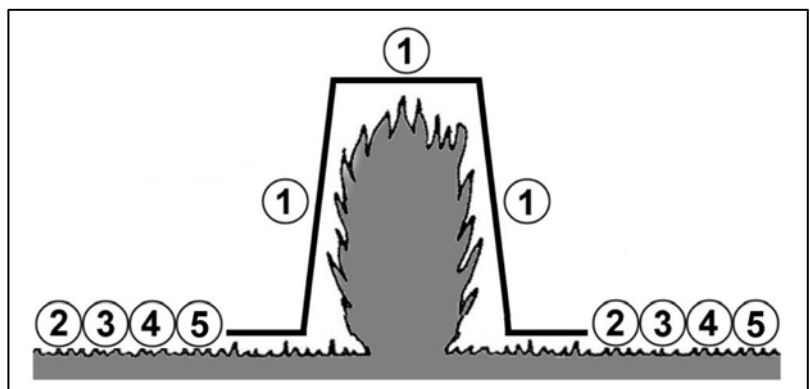

Roller Positions – Standard & Alternate

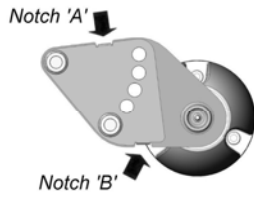

Standard Roller Position

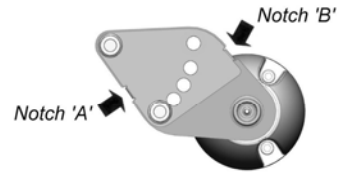

Alternative Roller position

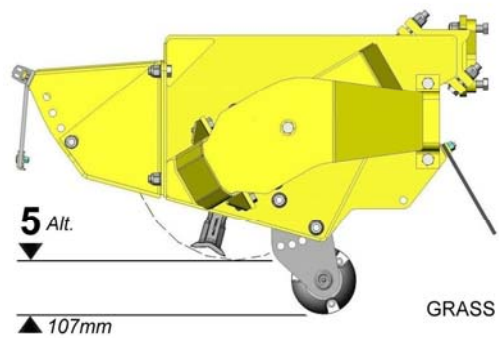
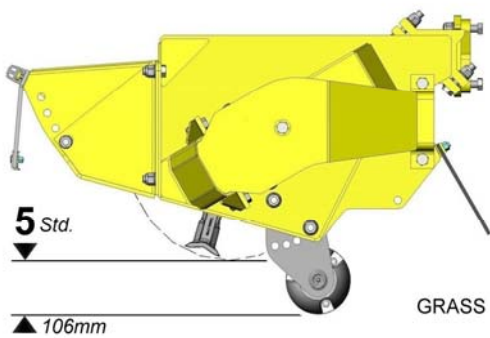
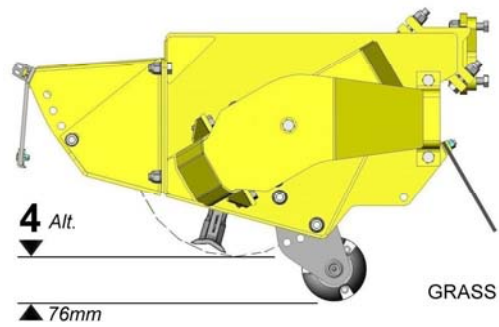
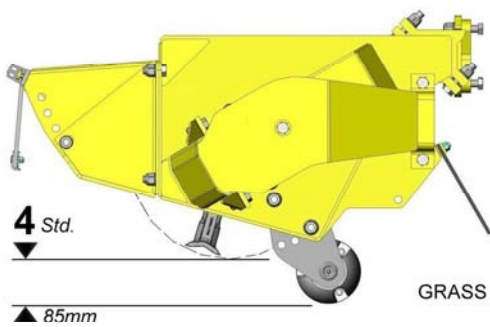
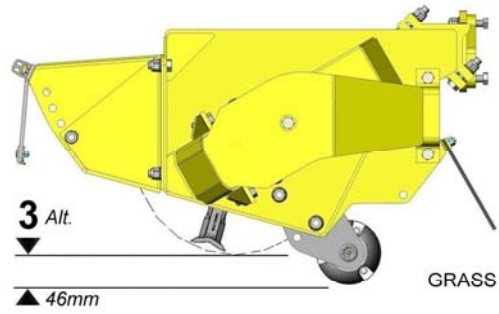
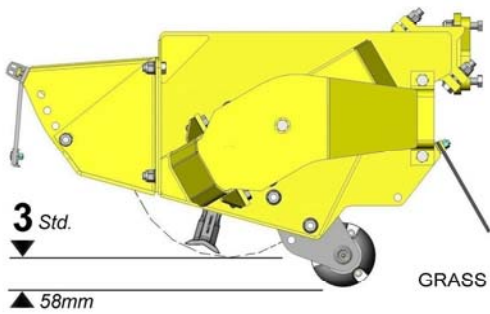
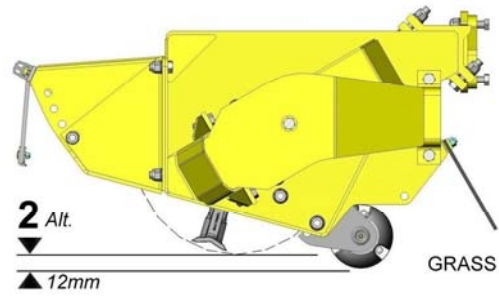
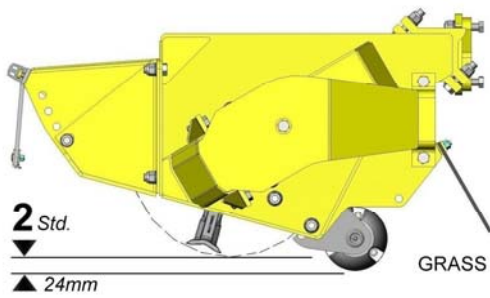
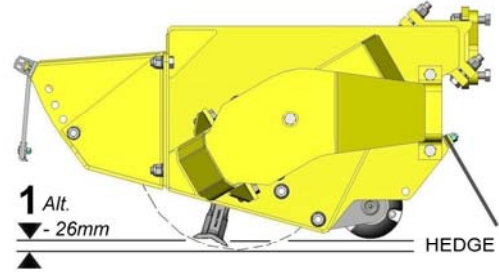
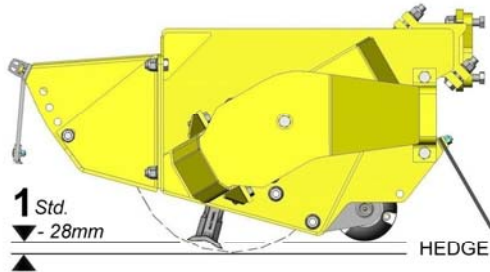

FLAILHEAD ARRANGEMENT – GRASS & VERGE MOWING

Roller Height

The roller position must always be set below the level of the skids, or rotor if skids are not fitted, i.e. in positions 2, 3, 4 or 5, - refer to roller positions on previous page.

Rotor Direction

When mowing the rotor must always cut with an upwards rotation.

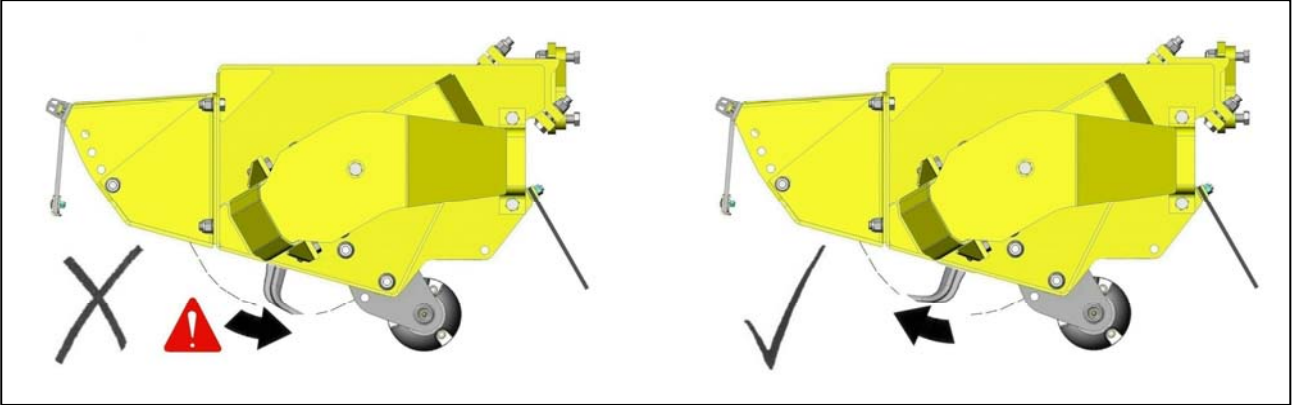

Front Hood

The front hood has 4 adjustment positions for height – the lowest possible position which allows the material to be cut to enter the head should always be used.

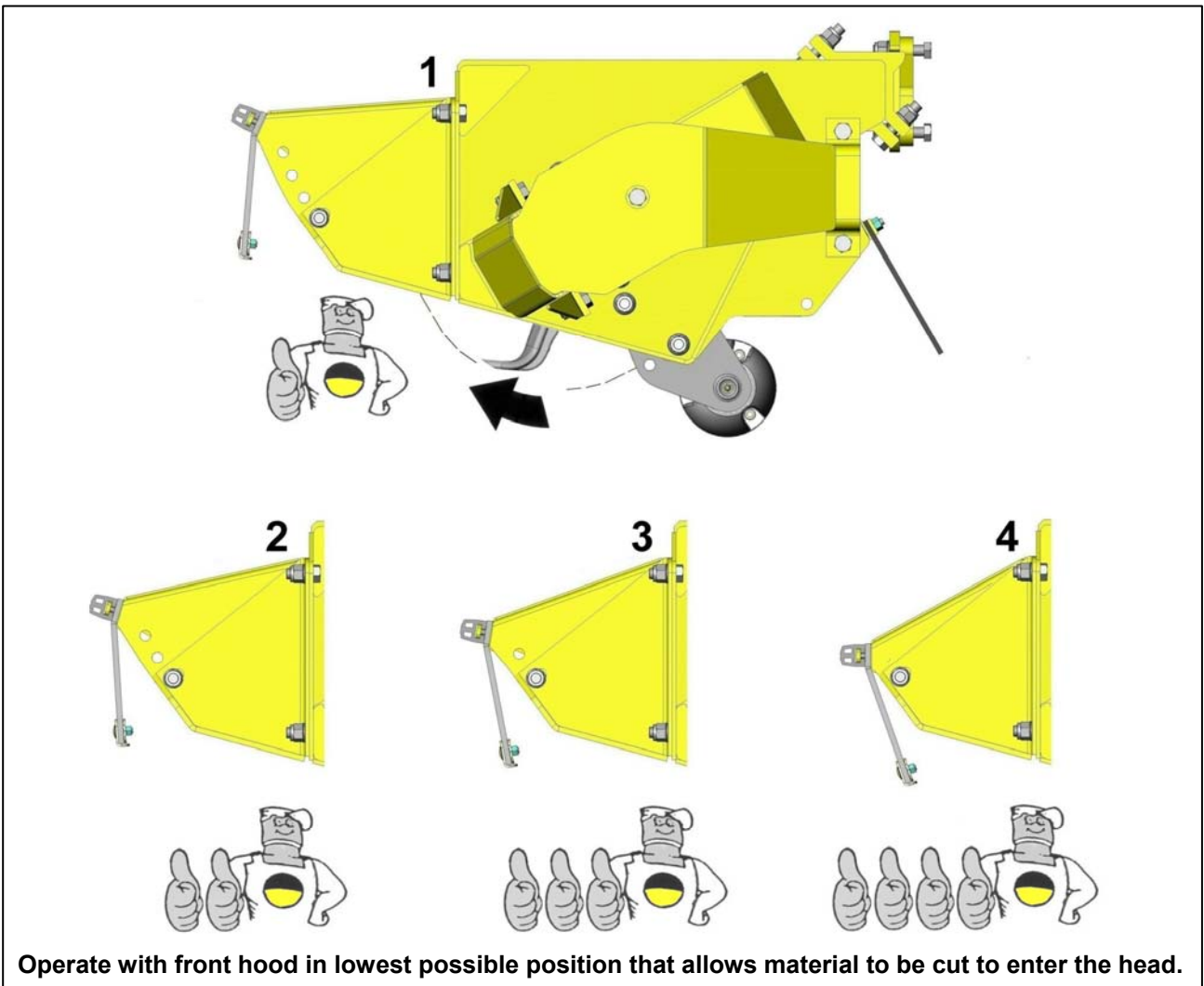

CAUTION:

Before attempting grass mowing ensure the flail head is set up correctly.

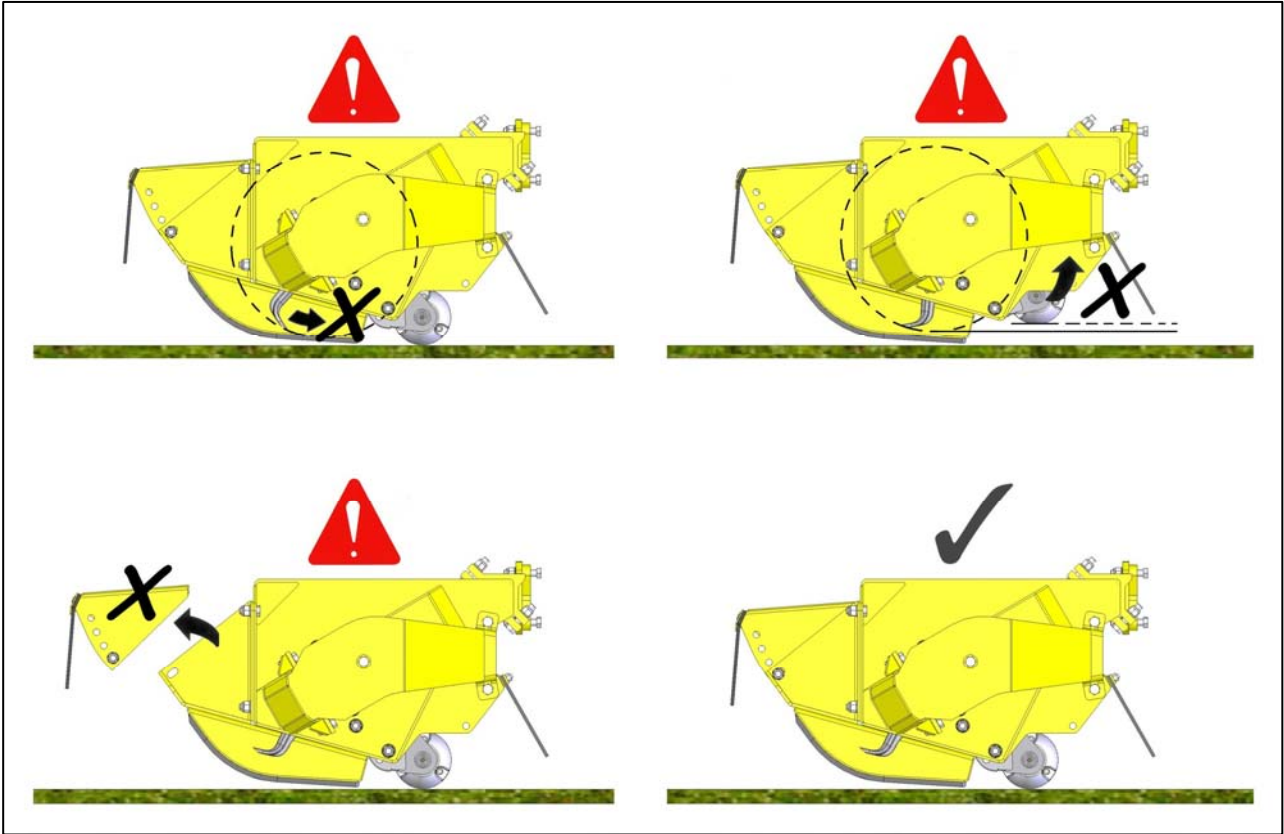

TRACTOR FORWARD SPEED

The material being cut determines tractor forward speed. Forward speed can be as fast as that which allows the flail head sufficient time to cut the vegetation properly.

Too fast a speed will be indicated by over frequent operation of the breakaway system, a fall off in tractor engine revs and a poor finish to the work leaving ragged uncut tufts and poorly mulched cuttings.

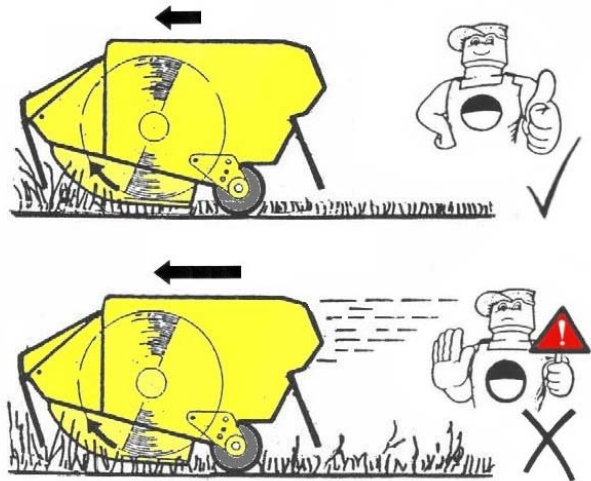

FLAILHEAD ARRANGEMENT - HEDGE CUTTING (Standard Duty)

Roller Height

The roller position must always be set above the level of the rotor in positions 1 - *refer to roller positions page.*

Rotor Direction

For the best finish the rotor should cut with an upwards rotation.

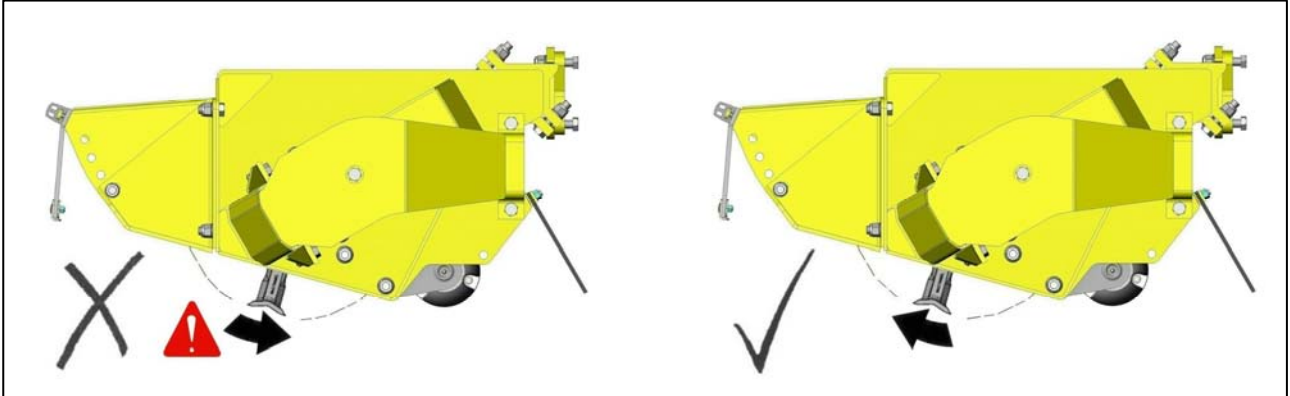

Front Hood

On universal heads the front rubber flaps, and skids if fitted, may be removed to aid the entry of the material to be cut into the flail head.

The front hood has 4 adjustment positions for height – the lowest possible position which allows the material to be cut to enter the head should always be used.

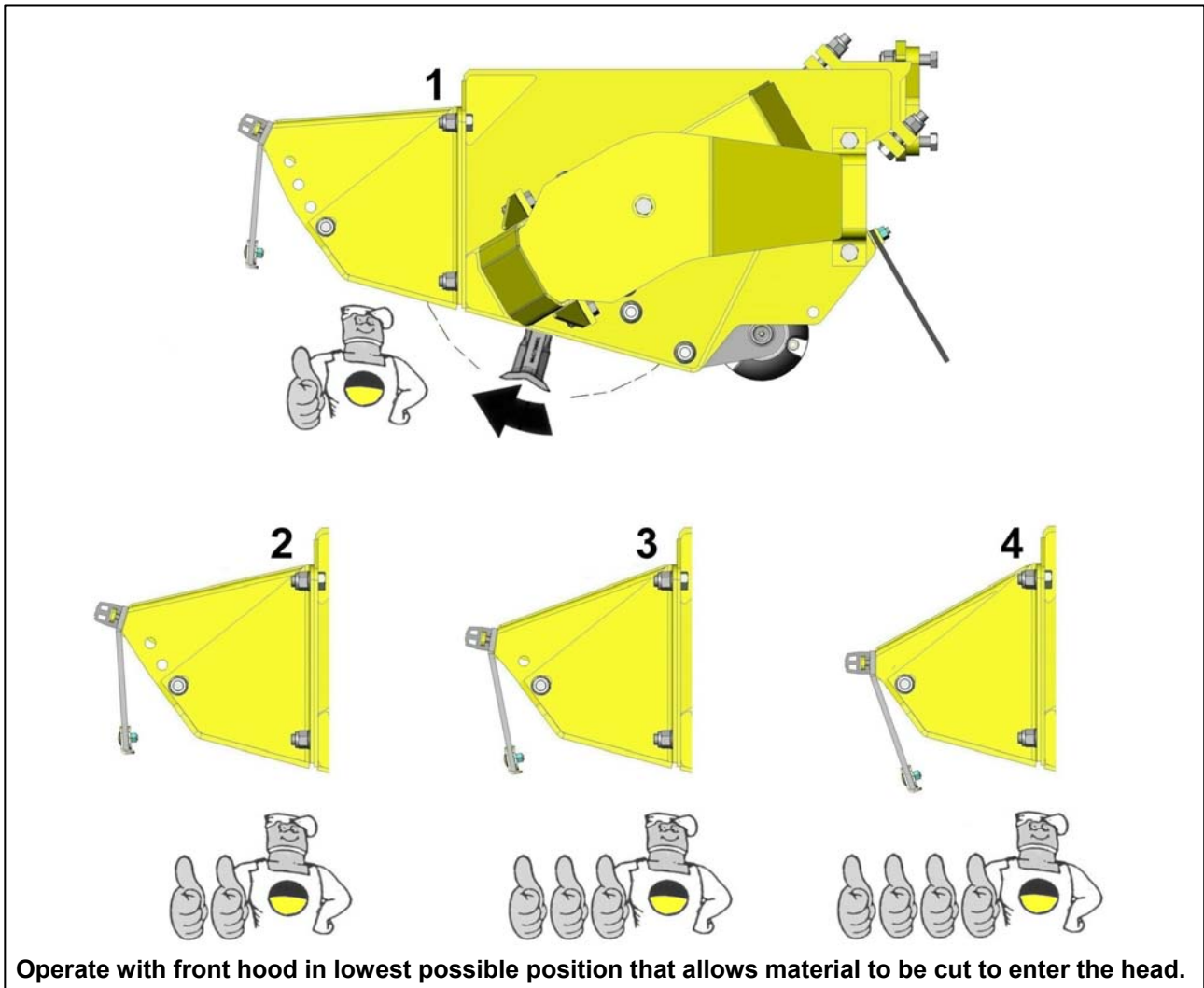

CAUTION:

Before attempting hedge cutting ensure the flail head is set up correctly.

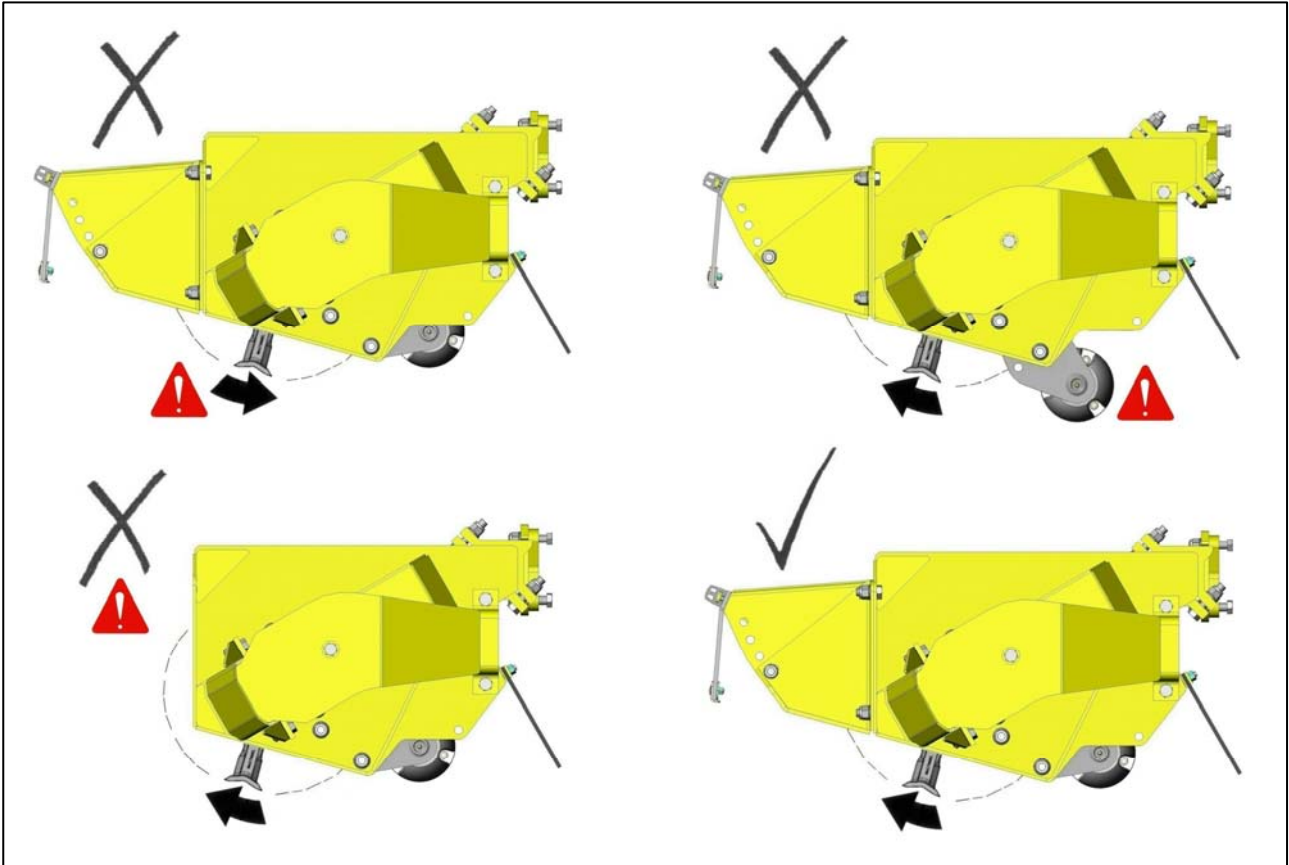

FLAILHEAD ARRANGEMENT - HEDGE CUTTING (Heavy Duty)

Roller Height

The roller position must always be set above the level of the rotor in positions 1 - refer to roller position page.

Rotor Direction

Where the size and density of material to be cut makes it necessary for the front hood and carrier plates to be removed to allow the rotor to cut, the rotor must always cut in a downwards rotation. It must be noted that this will result in a poorer finish to the work and will require more power than upward cutting.

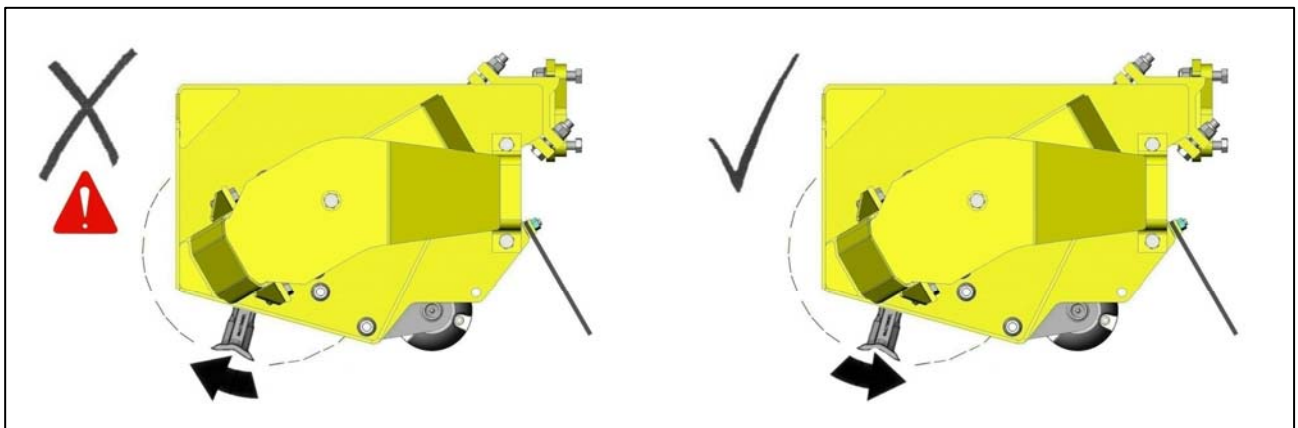

HEDGE CUTTING PROCEDURE



WARNING!

Never cut on the blind side of the hedge

It is impossible to see potential hazards or dangers and the position of the flail head may allow debris to be propelled through the hedge towards the tractor and the operator.

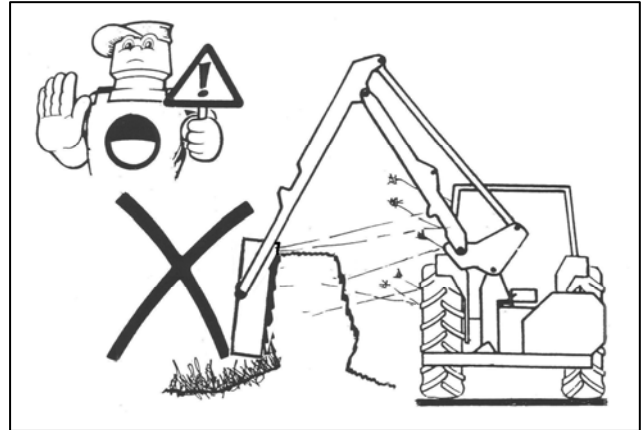

Cut the side and bottom of the field side first. This leaves the maximum thickness of hedge on the road side to prevent the possibility of debris being thrown through the hedge into the path of oncoming vehicles.

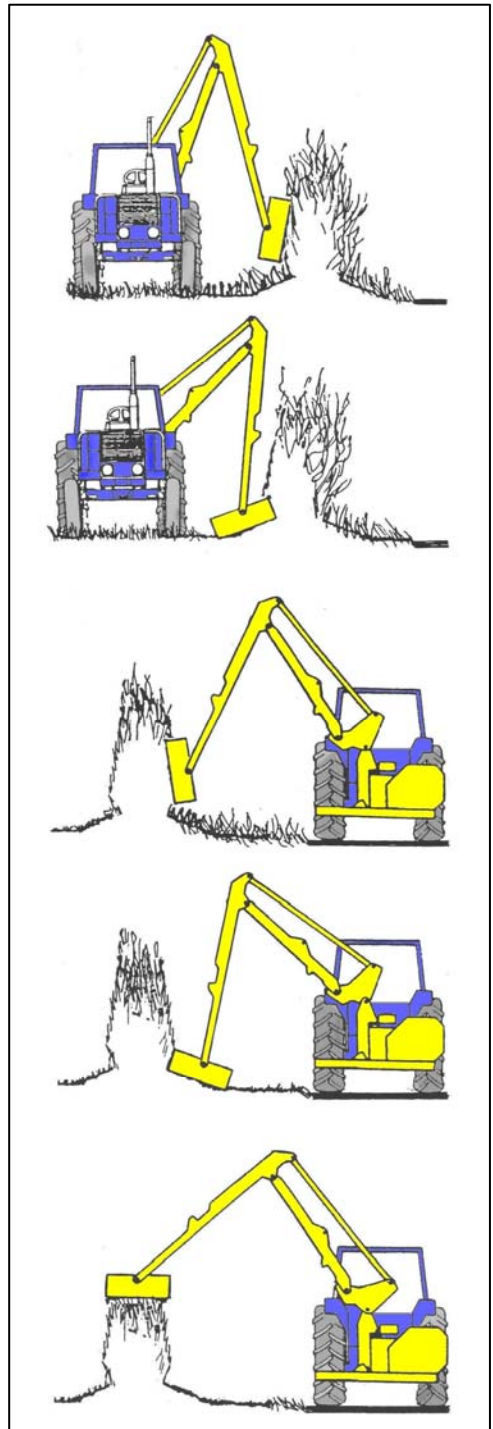





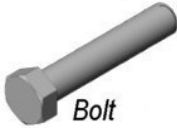

Cut the side and bottom of the road side.

Top cut the hedge to the height required.

FLAIL IDENTIFICATION

The Illustrations below show the various flails and fixings and their specific part numbers.

<p>F10 D.E. Cast Flail (Part No. 7314366D)</p>	<p>F10 D.E. Forged Flail (Part No. 41391.02)</p>				
<p>HEDGE</p>	<p>HEDGE</p>				
<p>FIXINGS ← Bolt: 7314201 → ← Bush: 7314225 → ← Washer: 0100206 → ← Locknut: 0141006 →</p>					
<p>F10 S.E. Cast Flail (Part No. 7390276)</p>	<p>F16 D.E. Cast Flail (Part No. 21904.02)</p>				
<p>HEDGE</p>	<p>HEDGE</p>				
<p>FIXINGS ← Bolt: 7314201 → ← Bush: 7314225 → ← Washer: 0100206 → ← Locknut: 0141006 →</p>					
<p>D.E. Omega Flail (Part No. T1840572)</p>	<p>F14 D.E. Cast Flail (Part No. 21904.05)</p>				
<p>HEDGE</p>	<p>HEDGE</p>				
<p><i>Omega Rotor use only</i></p>	<p>FIXINGS ← Bolt: 7390006 → Bolt: 7314201 → ← Bush: 21215.02 → Bush: 7314225 → ← Washer: 0100206 → ← Locknut: 0141006 →</p>				
<p>F10 Grass Flail (Part No. 7190315)</p>	<p>Forged Boot Flail (Part No. 7190462)</p>				
<p>GRASS</p>	<p>UNIVERSAL</p>				
<p>FIXINGS ← Bolt: 7314201 → ← Bush: 21215.02 → Bush: 7314225 → ← Spacer: 7190010 → Spacer: 7190172 → Shackle: 7190175 → ← Washer: 0100206 → ← Locknut: 0141006 →</p>					
 <p>Bolt</p>	 <p>Washer</p>	 <p>Bush</p>	 <p>Spacer</p>	 <p>Shackle</p>	 <p>Locknut</p>

MAINTENANCE

Frequently inspect the rotor assembly for damaged or missing flails – Never operate or attempt to run the rotor with flails missing, imbalance will cause severe vibration and can rapidly damage the rotor shaft bearings. As an emergency measure, if a flail is broken off or missing, removal of an opposing flail on the opposite side of the rotor will retain the balance. Replace the flails at the earliest possible opportunity and always replace in opposite pairs. Never match up a new flail with a sharpened or damaged flail as the latter will be lighter thus causing imbalance of the rotor.

Blunt flails absorb more power and leave an untidy finish to the work. They should be sharpened on a grindstone or with a portable grinder periodically. Always wear protective gear when sharpening flails.

Check on a regular basis, prior to operation that all bolts are tight and that torque figures are correct – refer to pre-operational check page details.

Lubrication

Grease daily the points indicated in the illustration below.

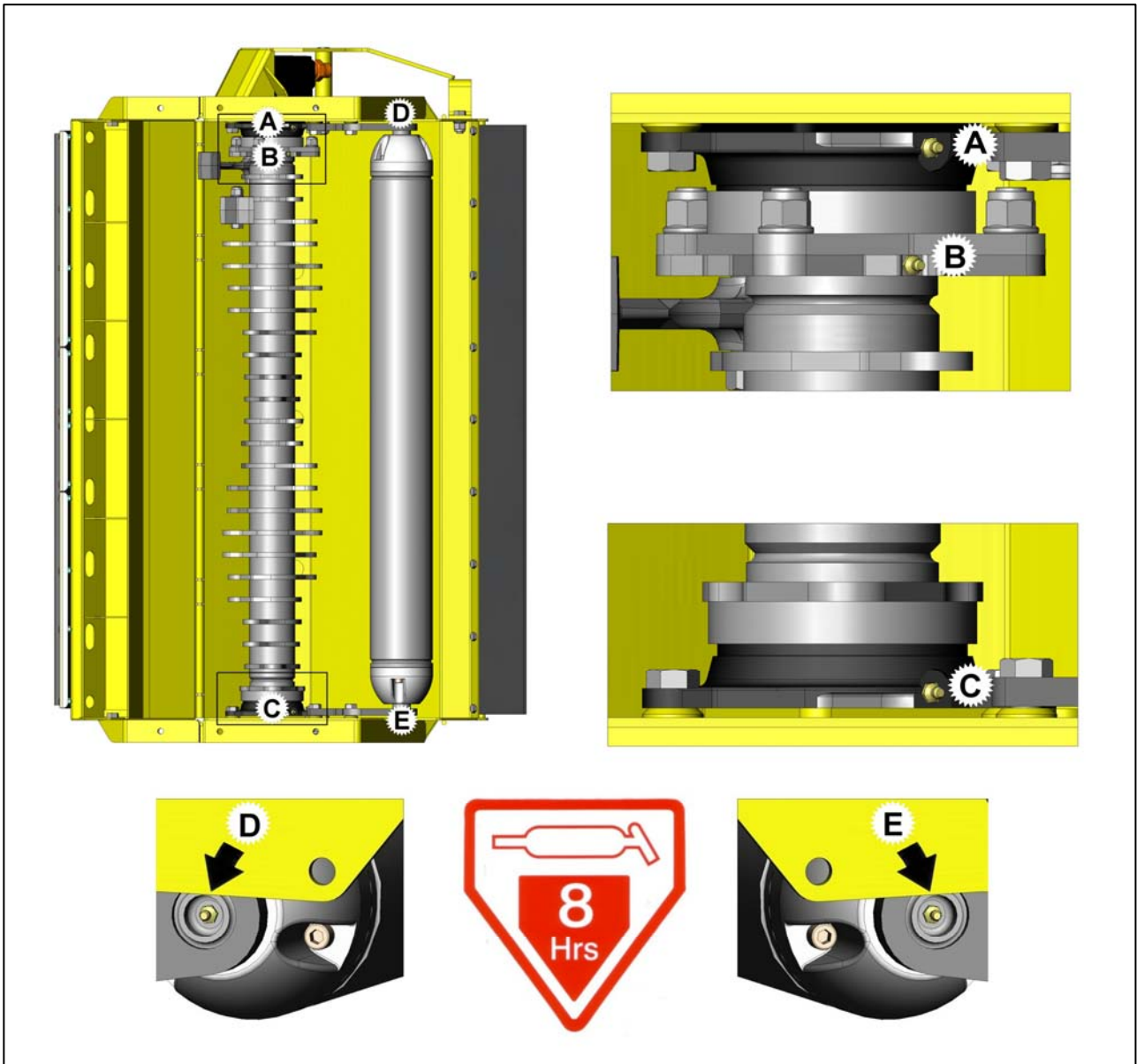

ROTOR SHAFT ALIGNMENT

Rotor shaft hub failure can usually be attributed to rotor misalignment caused by distortion of the flailhead due to the hood or casing receiving a violent blow against an obstruction during work or by dropping the flail head heavily to the ground. These actions should, wherever possible, be avoided.

Where rotor alignment is incorrect or when refitting or replacing rotor components it is imperative that the following procedure for re-assembly is adhered to:

Procedure for re-assembly is as follows:-

1. Press the new bearing fully into the housing and then press the complete assembly onto the rotor shaft until the bearing inner race is firmly against the rotor shoulder.
2. Support the head off the ground in a vertical position. Offer up the complete rotor shaft into the casing, and locate the lower mounting bolts. Tighten the nuts sufficiently to take out all movement and then check the hole alignment at the top end of the casing. If the mounting bolts will not readily fit into place, release the lower bolts and shim between the casing boss and bearing housing until the top holes are aligned.
3. Locate the three top mounting bolts and then tighten the three lower bolts and nuts completely – *torque to a setting of approximately 162Nm (120 ft-lb.)*.
4. Check for clearance between the top bearing housing and casing, and completely shim all gaps before tightening the three mounting bolts to the same torque as above. If there is not clearance between the housing and casing, the bosses will need to be 'ground off' in order to provide clearance for the adding of shims. *Failure to shim all gaps will tend to draw the bearing from the shaft when the bolts are tightened.*

Note

Two sizes of shim are available from McConnel; these are:

Part No. 8121043 for 0.4mm (.015")

Part No. 8121044 for 0.6mm (.025")

Alternatively thin spacing washers .2 may be used. The welded bosses in the casing may be of varying depths - this is a jiggling requirement during manufacture of the head and should not be regarded as a fault.

5. Finally, with the flail head horizontal, turn the rotor over by hand. There should be no binding or tight spots. Replace motor but do not bolt in place, when the rotor is rotated by hand the motor should not move. Movement up and down or side to side indicates a problem.

Warning: Failure to correctly align the rotor shaft may result in the motor shaft breaking.

6. The Coupling should be fitted on to the Motor and the nut tightened to a maximum torque setting of 80Nm (60 ft-lb.) - **Do not exceed this value.** Prior to the fitting of the motor, the hub and coupling splines should be liberally coated with Morris's K65MS high temperature grease, or equivalent. Experience has indicated that in addition to the pre-pack with Morris's K64MS grease supplied, greasing the rotor bearings twice daily can considerably improve the longevity of the drive hub and coupling.

Rotor Shaft Shim Fitment

Rotor mis-aligned

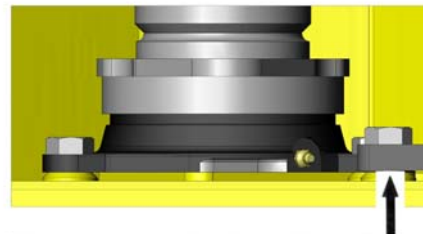
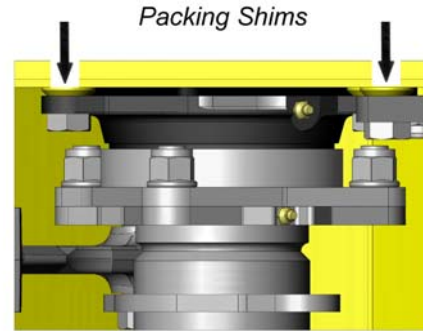
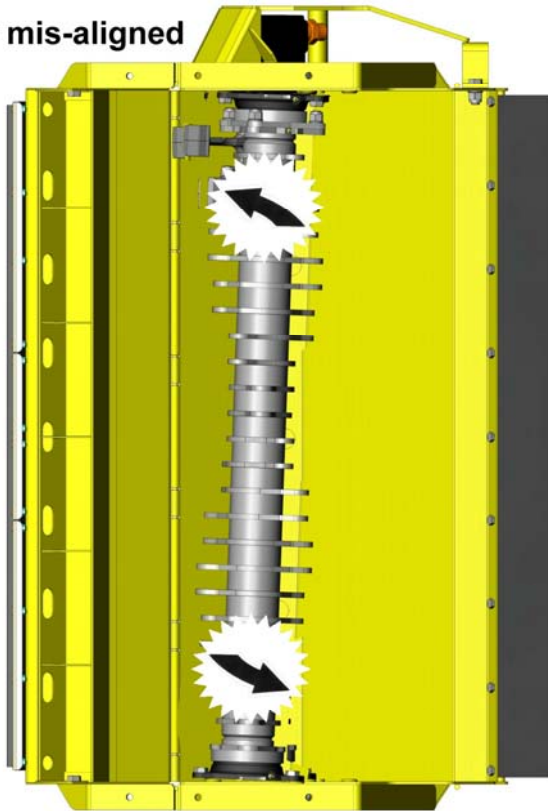

Shim where required to adjust alignment

Rotor aligned

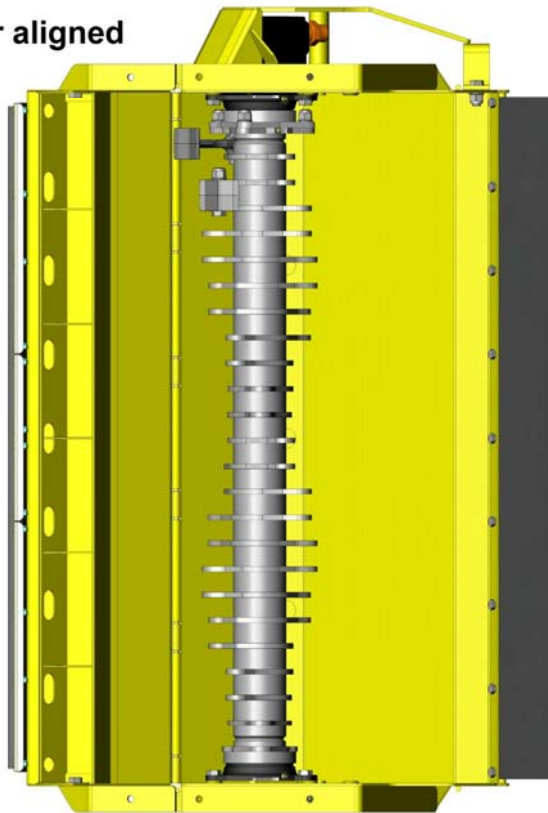



For best performance ...

USE ONLY GENUINE McCONNEL SERVICE PARTS

*To be assured of the latest design improvements purchase your
'Genuine Replacements' from the 'Original Equipment Manufacturer'*

McCONNEL LIMITED

Through your local Dealer or Stockist

Always quote:

- ***Machine Type***
- ***Serial Number***
- ***Part Number***

*Design improvements may alter some of the parts listed in this manual –
the latest part will always be supplied when it is interchangeable with an earlier one.*

1.5M MULTICUT CASING

McCONNEL

Module(s): 22494.04

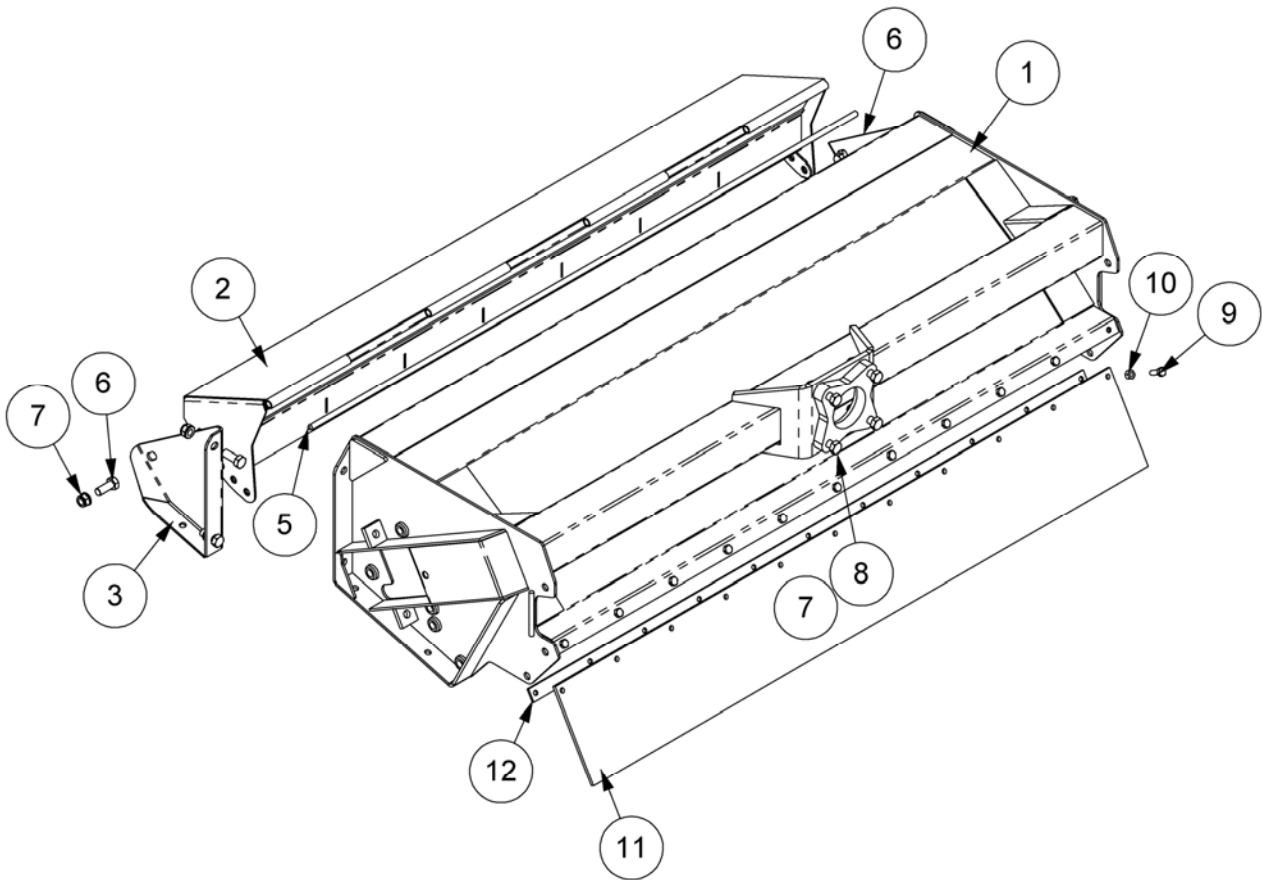

REF.	QTY.	PART No.	DESCRIPTION
		22494.04	1.5M MULTICUT FLAILHEAD CASING
1	1	42427.06	1.5m HEAD CASING
2	1	21748.03	HOOD -1.5m MULTICUT
3	1	22492.03	HOOD SUPPORT - L/H
4	1	22492.04	HOOD SUPPORT - R/H
5	1	21956.01	HOOD PIVOT BAR
6	6	30.073.25	BOLT
7	10	9100024	SELF-LOCKING FLANGE NUT
8	4	12.714.75	BOLT
9	11	9313065	SETSCREW
10	11	9143005	SELF-LOCKING NUT
11	1	42440.01	REAR FLAP
12	1	42439.01	CLAMP STRIP - REAR

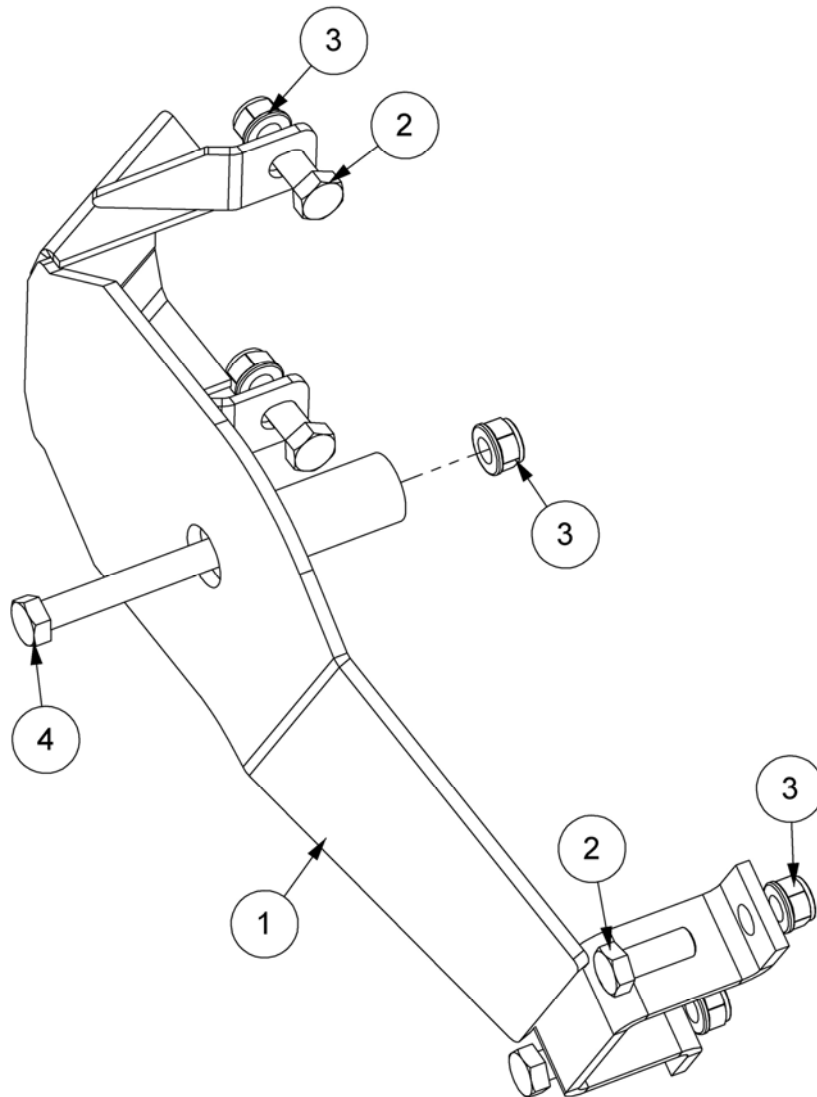

REF.	QTY.	PART No.	DESCRIPTION
		22496.03	L/H MOTOR COVER ASSEMBLY
1	1	42282.03	MOTOR COVER
2	4	30.073.25	BOLT
3	5	9100024	SELF-LOCKING FLANGE NUT
4	1	9200034	BOLT

REF.	QTY.	PART No.	DESCRIPTION
		22496.04	MOTOR COVER ASSEMBLY
1	1	42282.04	MOTOR COVER
2	4	30.073.25	BOLT
3	5	9100024	SELF-LOCKING FLANGE NUT
4	1	9200034	BOLT

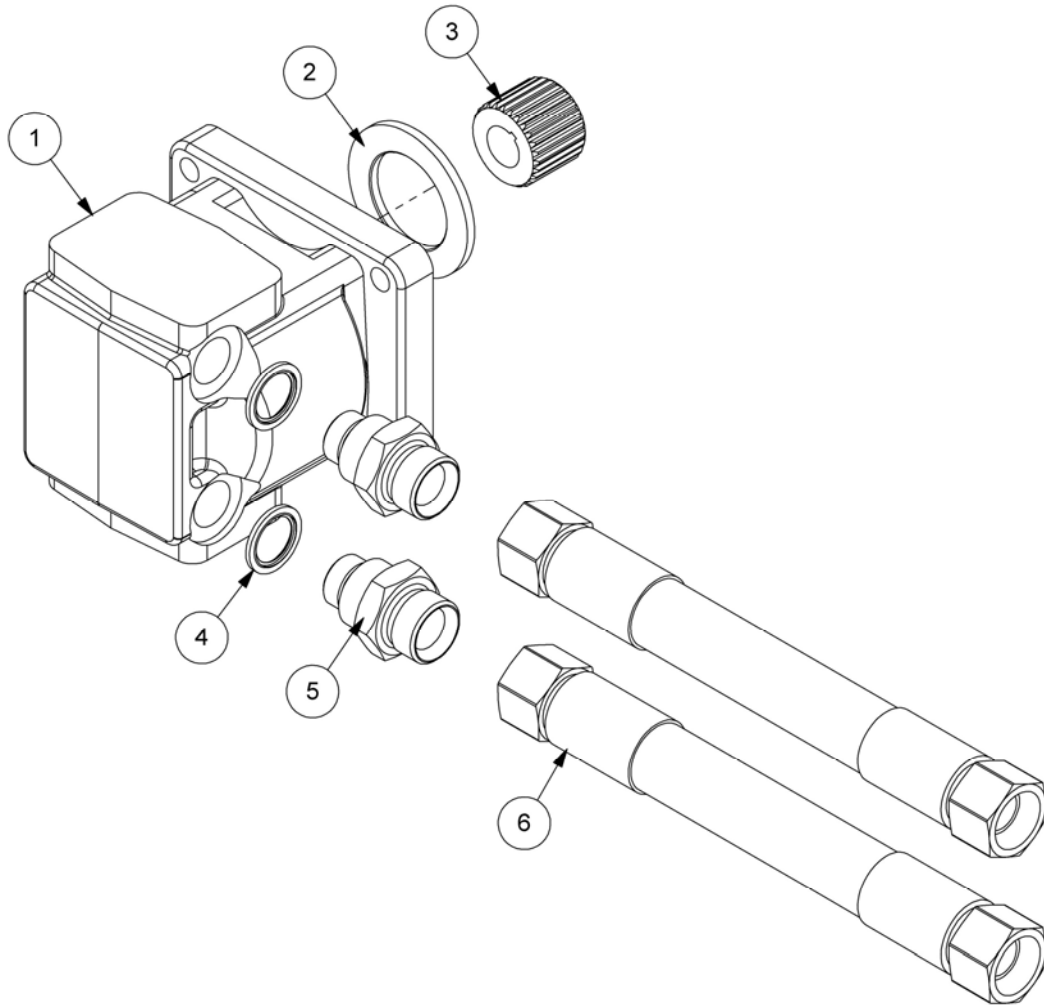

REF.	QTY.	PART No.	DESCRIPTION
		22495.13	100LPM DRIVE MODULE 54HP
1	1	8301302	MOTOR 54HP
2	1	7190015	LOCATING WASHER
3	1	43390.02	DRIVE COUPLING
4	2	8650106	BONDED SEAL
5	2	8581295	ADAPTOR
6	2	8501269	HOSE - 1" BSP FS/FS x 1450mm

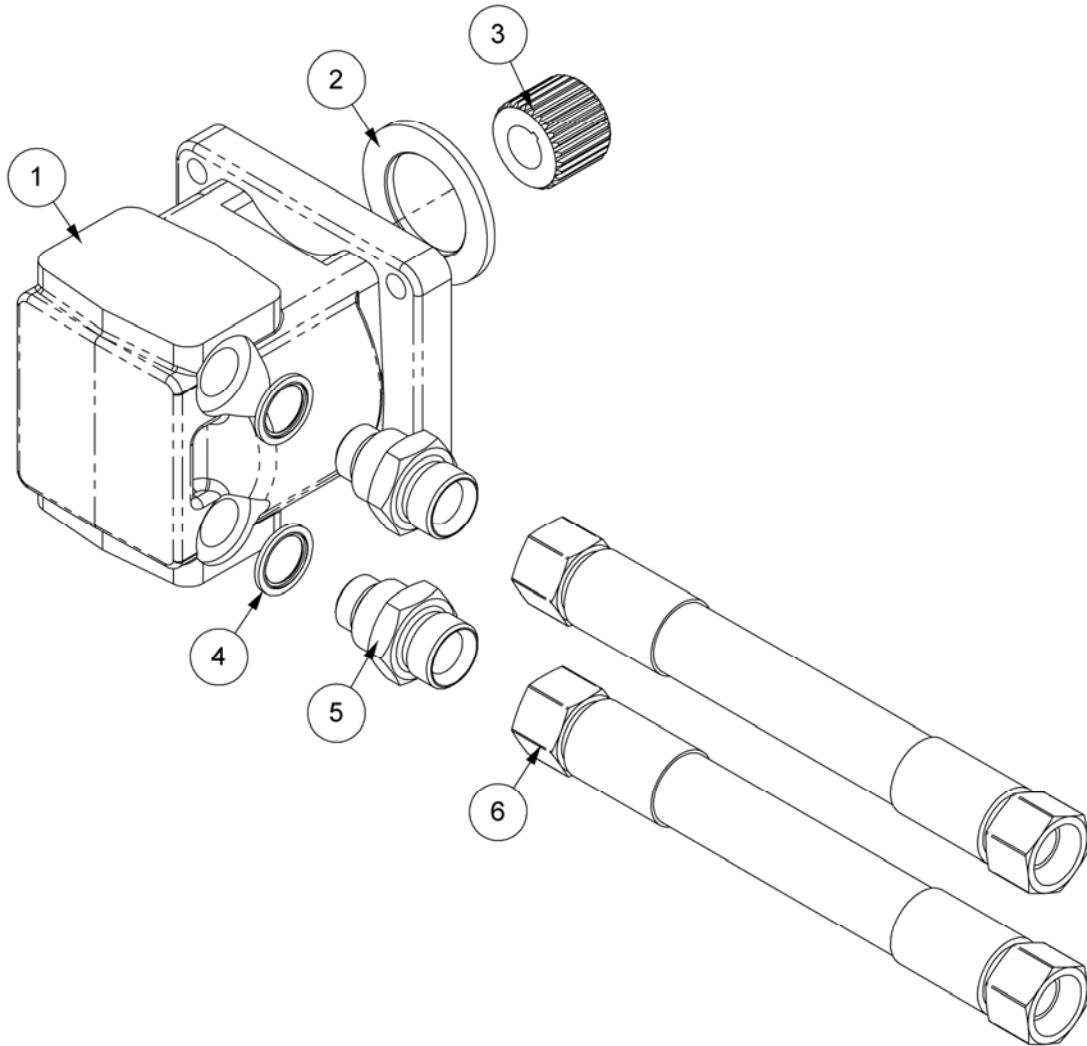

REF.	QTY.	PART No.	DESCRIPTION
		22495.04	65HP DRIVE ASSEMBLY
1	1	8301320	MOTOR - BACK PORTED
2	1	7190015	LOCATING WASHER
3	1	43390.02	DRIVE COUPLING - 27 TOOTH
4	2	8650106	BONDED SEAL
5	2	8581295	ADAPTOR
6	2	10.011.25	HOSE - 1" BSP FS/FS x 1500mm
		8699236	SEAL KIT
		8629209	SHAFT SEAL (x2)

QUAD DRIVE ASSEMBLY

McCONEL

Module(s): 22498.03

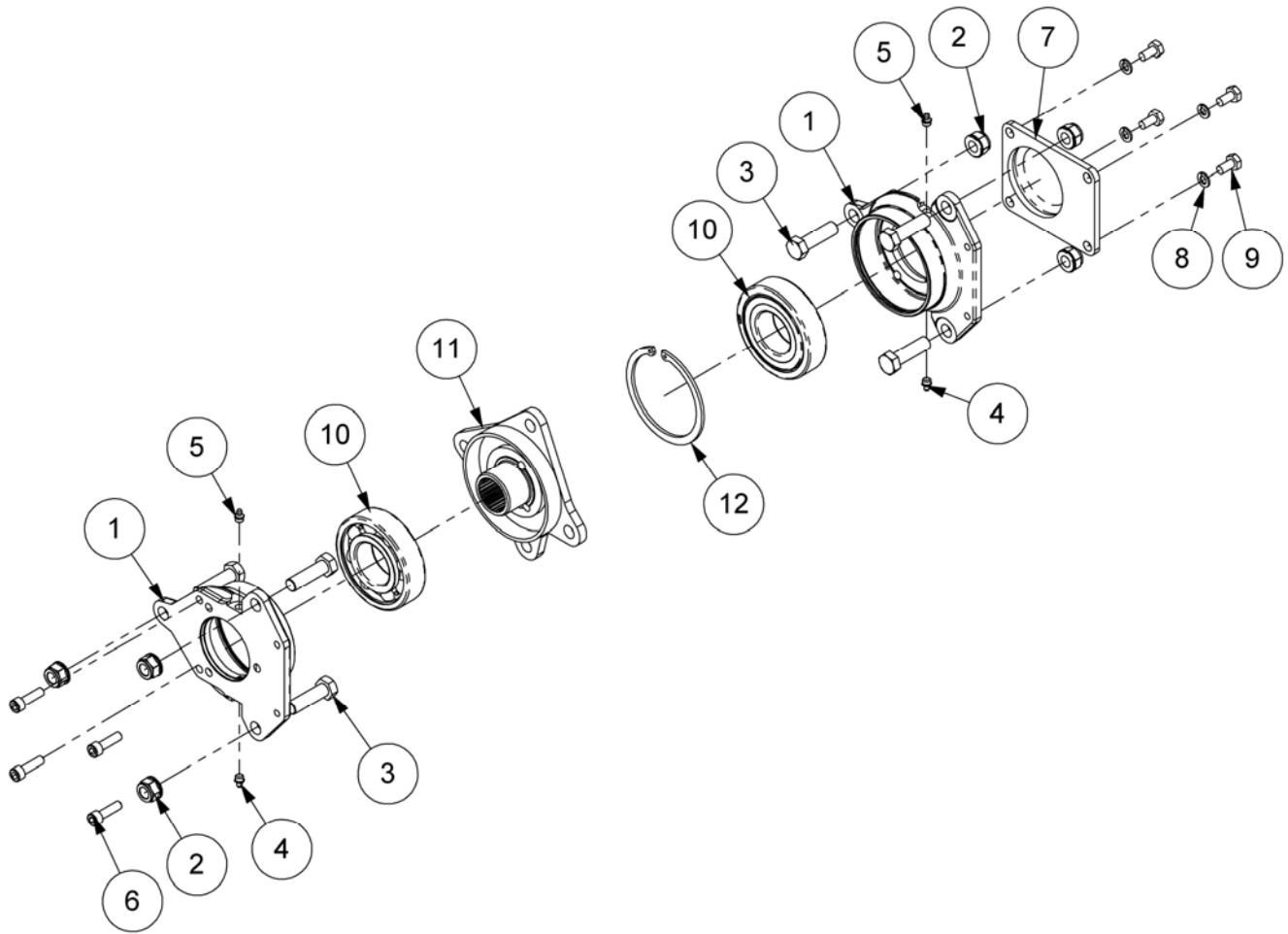

REF.	QTY.	PART No.	DESCRIPTION
		22498.03	MULTICUT QUAD DRIVE ASSEMBLY
1	2	7190261	BEARING HOUSING
2	6	9100024	SELF-LOCKING FLANGE NUT
3	6	9200024	BOLT
4	2	0901121	GREASE NIPPLE - STRAIGHT
5	2	0901125	GREASE NIPPLE - 45°
6	4	9300144	CAPSCREW
7	1	7190292	COVER PLATE
8	4	9100205	SPRING WASHER
9	4	9313045	SETSCREW
10	2	0600018	BALL BEARING
11	1	22269.02	DRIVE HUB - QUAD DRIVE
12	1	7190022	INTERNAL CIRCLIP
13	<i>as req'd</i>	8121043	SHIM - 0.4mm
14	<i>as req'd</i>	8121044	SHIM - 0.6mm

1.5M ROTORS c/w F10DE FLAILS

McCONEL

Module(s): 22497.11, 22497.13

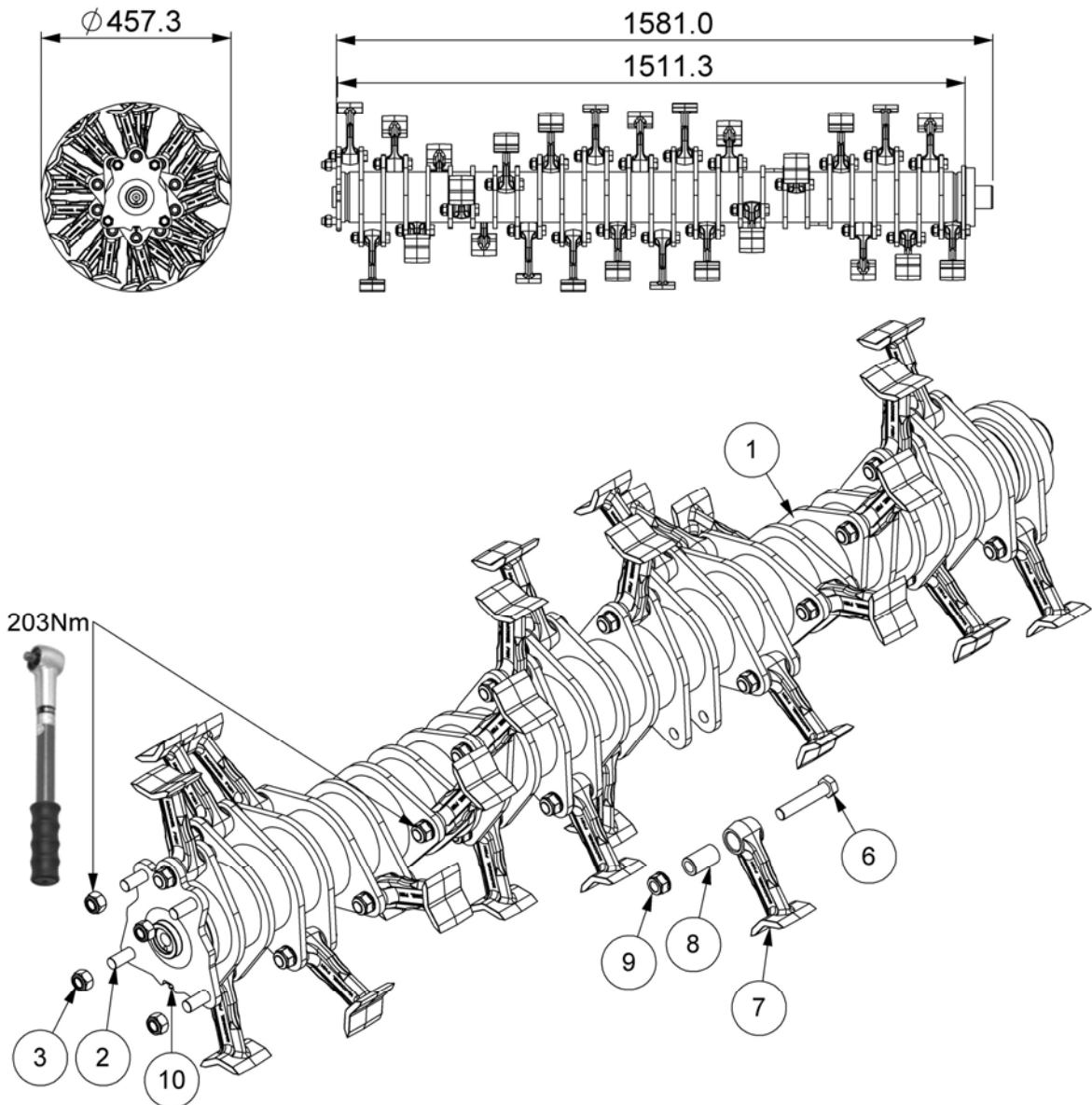

REF.	QTY.	PART No.	DESCRIPTION
		22497.11	1.5M ROTOR c/w F10DE CAST FLAILS
		22497.13	1.5M ROTOR c/w F10DE FORGED FLAILS
1	1	22269.05	1.5m QUAD ROTOR - WRAP ROUND
2	4	9353097	CAPSCREW
3	4	9163007	NYLOC NUT
4	5	8121043	SHIM - 0.4mm
5	5	8121044	SHIM - 0.6mm
6	28	7390025	SPECIAL BOLT
7	28	7314366D	F10DE FLAIL (CAST)
	28	41391.01	F10DE FLAIL (FORGED)
8	28	21215.01	FLAIL PIVOT BUSH
9	28	9100024	SELF-LOCKING FLANGE NUT
10	1	0901161	GREASE NIPPLE - STRAIGHT

1.5M ROTOR c/w F10SE FLAILS

McCONEL

Module(s): 22497.12

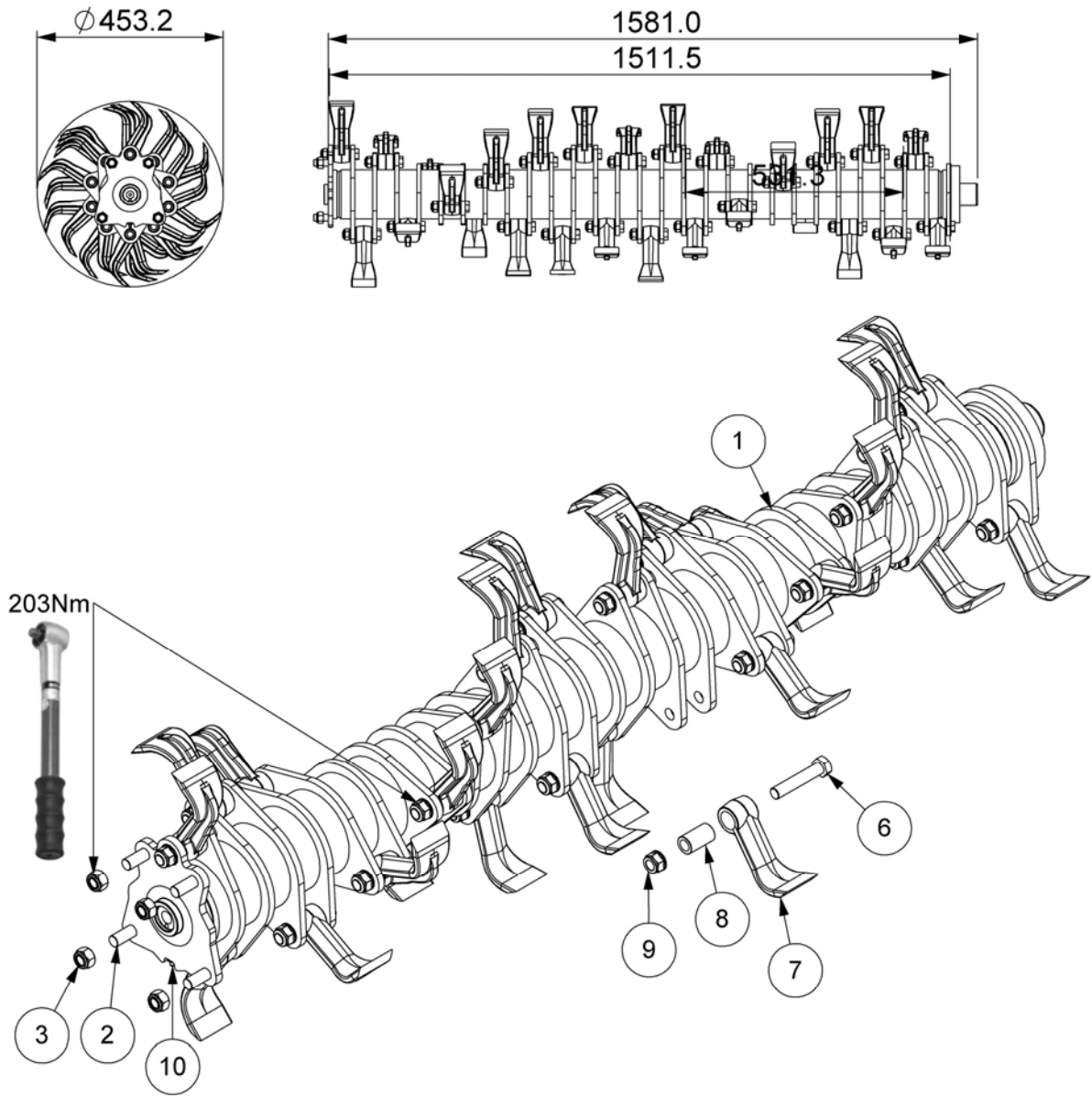

REF.	QTY.	PART No.	DESCRIPTION
		22497.12	1.5M ROTOR ASSEMBLY
1	1	22269.05	1.5m QUAD ROTOR - WRAP ROUND
2	4	9353097	CAPSCREW
3	4	9163007	NYLOC NUT
4	5	8121043	SHIM - 0.4mm
5	5	8121044	SHIM - 0.6mm
6	28	7390025	SPECIAL BOLT
7	28	7390276	F10 SE FLAIL (CAST)
8	28	21215.01	FLAIL PIVOT BUSH
9	28	9100024	SELF-LOCKING FLANGE NUT
10	1	0901161	GREASE NIPPLE - STRAIGHT

1.5M ROTOR c/w F16DE FLAILS

McCONEL

Module(s): 22497.14

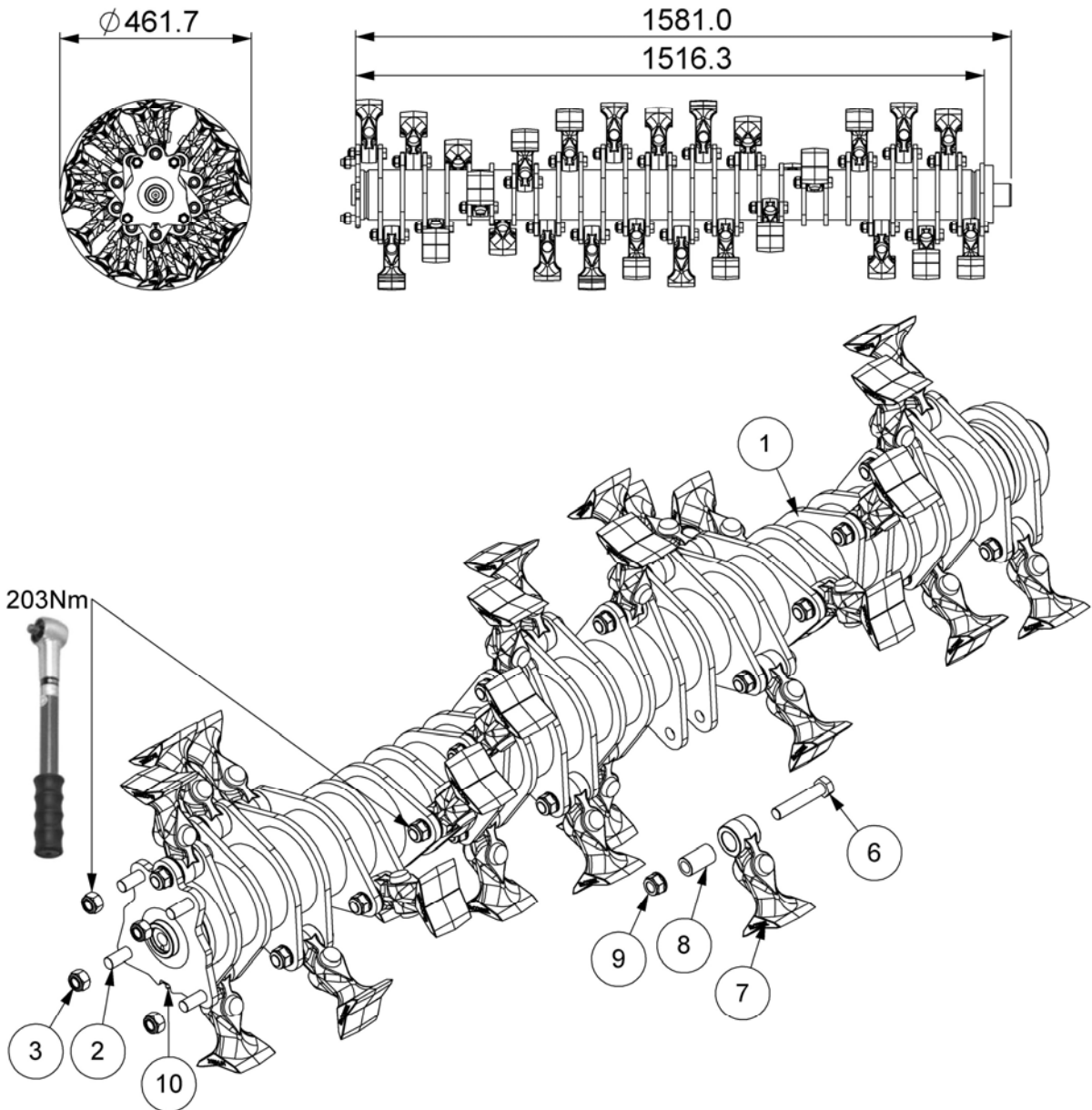

REF.	QTY.	PART No.	DESCRIPTION
		22497.14	1.5M ROTOR c/w F16DE CAST FLAILS
1	1	22269.05	1.5m QUAD ROTOR - WRAP ROUND
2	4	9353097	CAPSCREW
3	4	9163007	NYLOC NUT
4	5	8121043	SHIM - 0.4mm
5	5	8121044	SHIM - 0.6mm
6	28	7390025	SPECIAL BOLT
7	28	21904.02	F16DE FLAIL (CAST)
8	28	21215.01	FLAIL PIVOT BUSH
9	28	9100024	SELF-LOCKING FLANGE NUT
10	1	0901161	GREASE NIPPLE - STRAIGHT

1.5M ROTOR c/w GRASS FLAILS

McCONEL

Module(s): 22497.15

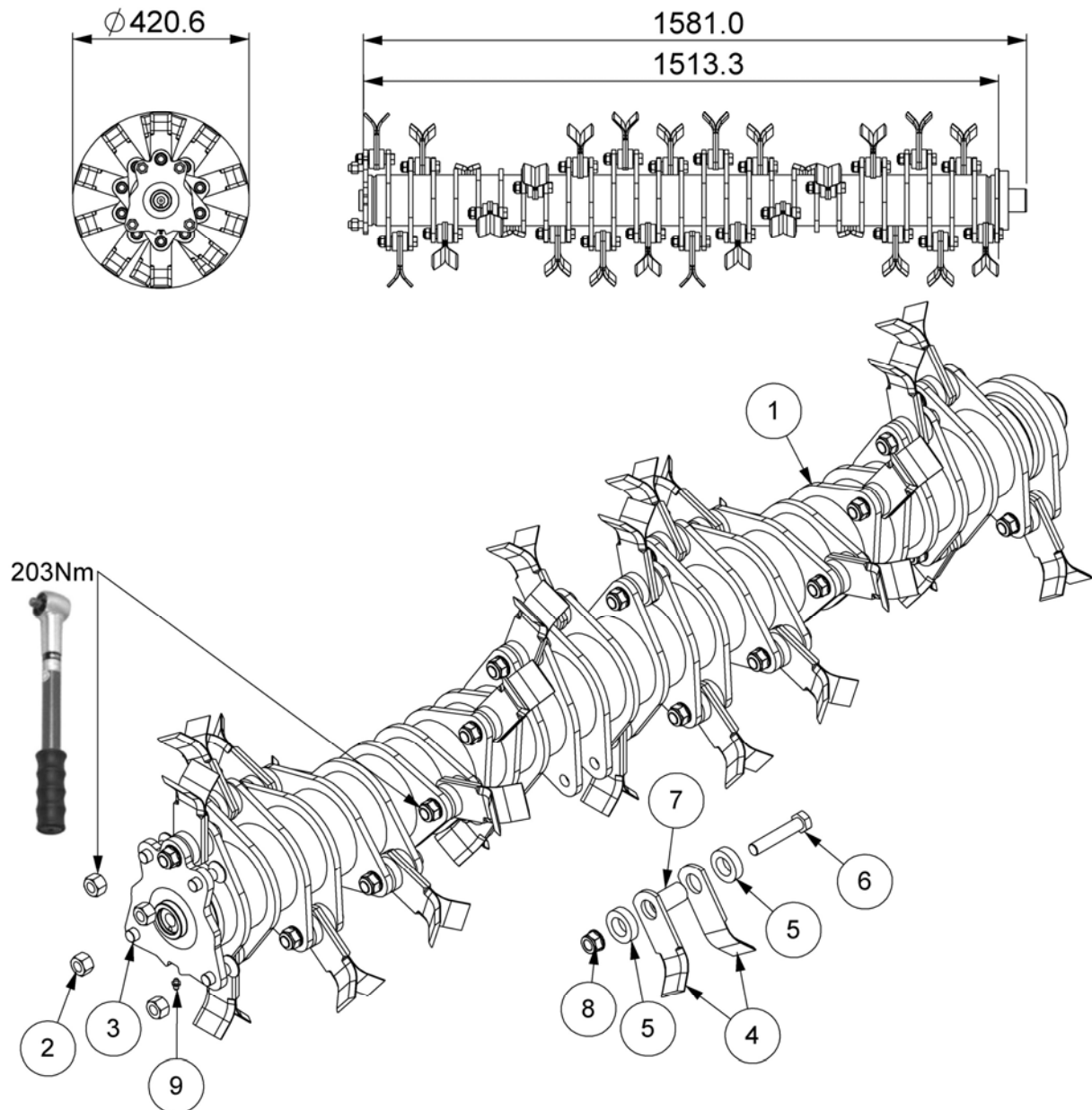

REF.	QTY.	PART No.	DESCRIPTION
		22497.15	1.5M ROTOR c/w F10 GRASS FLAILS
1	1	22269.05	1.5m QUAD ROTOR - WRAP ROUND
2	4	9143007	SELF-LOCKING NUT
3	4	9353097	CAPSCREW
4	56	7190315	F10 GRASS FLAIL
5	56	7190010	SPACER
6	28	7390025	SPECIAL BOLT
7	28	21215.01	FLAIL PIVOT BUSH
8	28	9100024	SELF-LOCKING FLANGE NUT
9	1	0901161	GREASE NIPPLE - STRAIGHT

1.5M OMEGA ROTOR ASSEMBLY

McCONNEL

Module(s): 22497.17

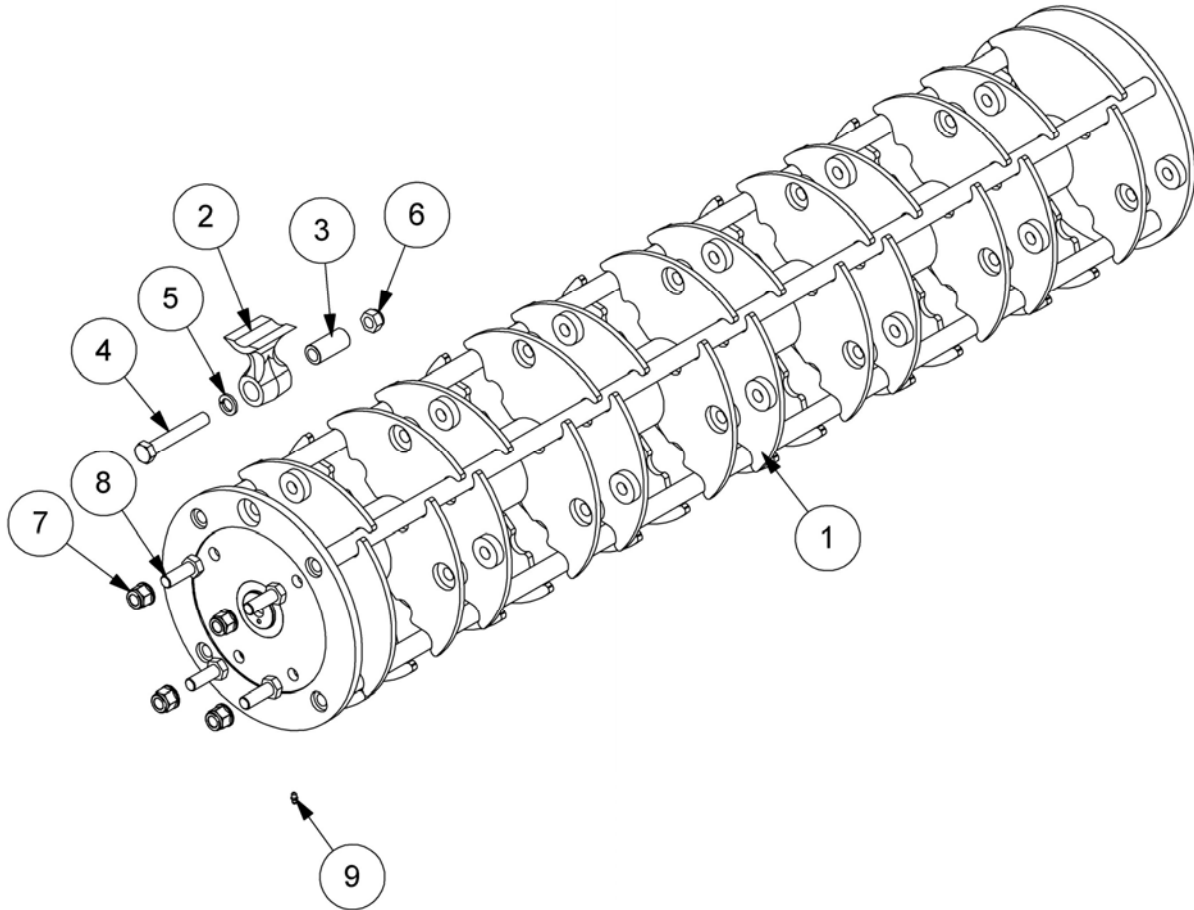

REF.	QTY.	PART No.	DESCRIPTION
		22497.17	1.5M OMEGA ROTOR ASSEMBLY
1	1	22269.09	1.5m OMEGA ROTOR
2	24	1840572	FLAIL BLADE (ROLLICOUP)
3	24	21215.02	FLAIL BUSH
4	24	7390006	SPECIAL GRADE BOLT
5	24	0100206	SPRING WASHER
6	24	0141006	UNF CLEVELOC NUT
7	4	9100024	S/LOCKING FLANGE NUT
8	4	9200028	BOLT
9	1	0901161	GREASE NIPPLE

1.5M ROLLER ASSEMBLY

Module(s): 21523.18

McCONNEL

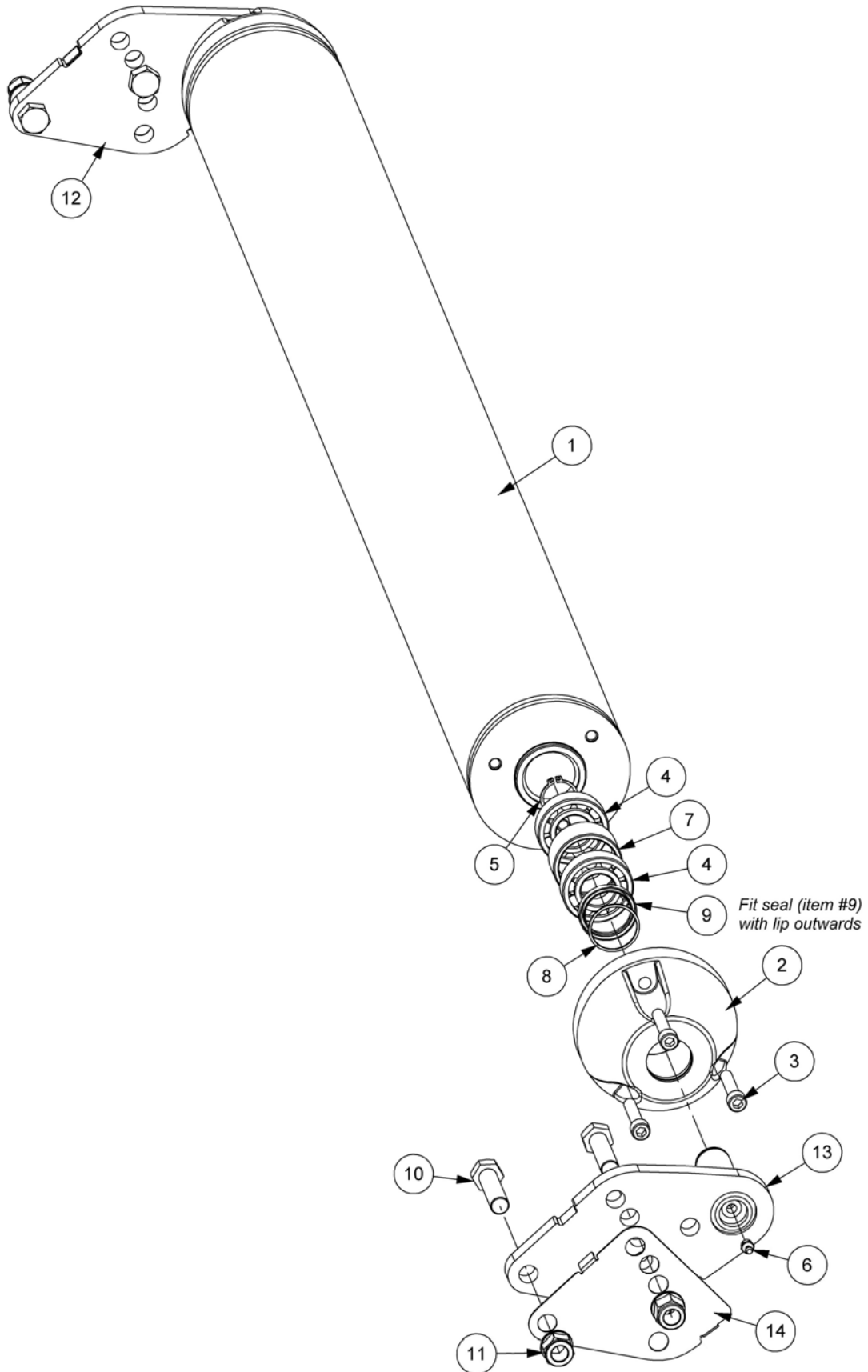

1.5M ROLLER ASSEMBLY**McCONNEL**

Module(s): 21523.18

REF.	QTY.	PART No.	DESCRIPTION
		21523.18	1.5M ROLLER ASSEMBLY
1	1	21394.27	ROLLER - 1.5m
2	2	21394.32	ROLLER END CAP
3	6	9343105	CAPSCREW
4	4	0600111	BALL BEARING
5	2	0401230	EXTERNAL CIRCLIP
6	2	0901121	GREASE NIPPLE - STRAIGHT
7	2	21523.31	BEARING SPACER
8	2	0402240	INTERNAL SPIROLOX RING
9	2	8629239	ROTARY SHAFT SEAL
10	4	9200031	BOLT
11	4	9100024	SELF-LOCKING FLANGE NUT
12	1	21524.15	ROLLER BRACKET - R/H
13	1	21524.14	ROLLER BRACKET - L/H
14	2	42257.10	SHIM -1.2mm

FRONT FLAP KIT

Module(s): 7198315

McCONNEL

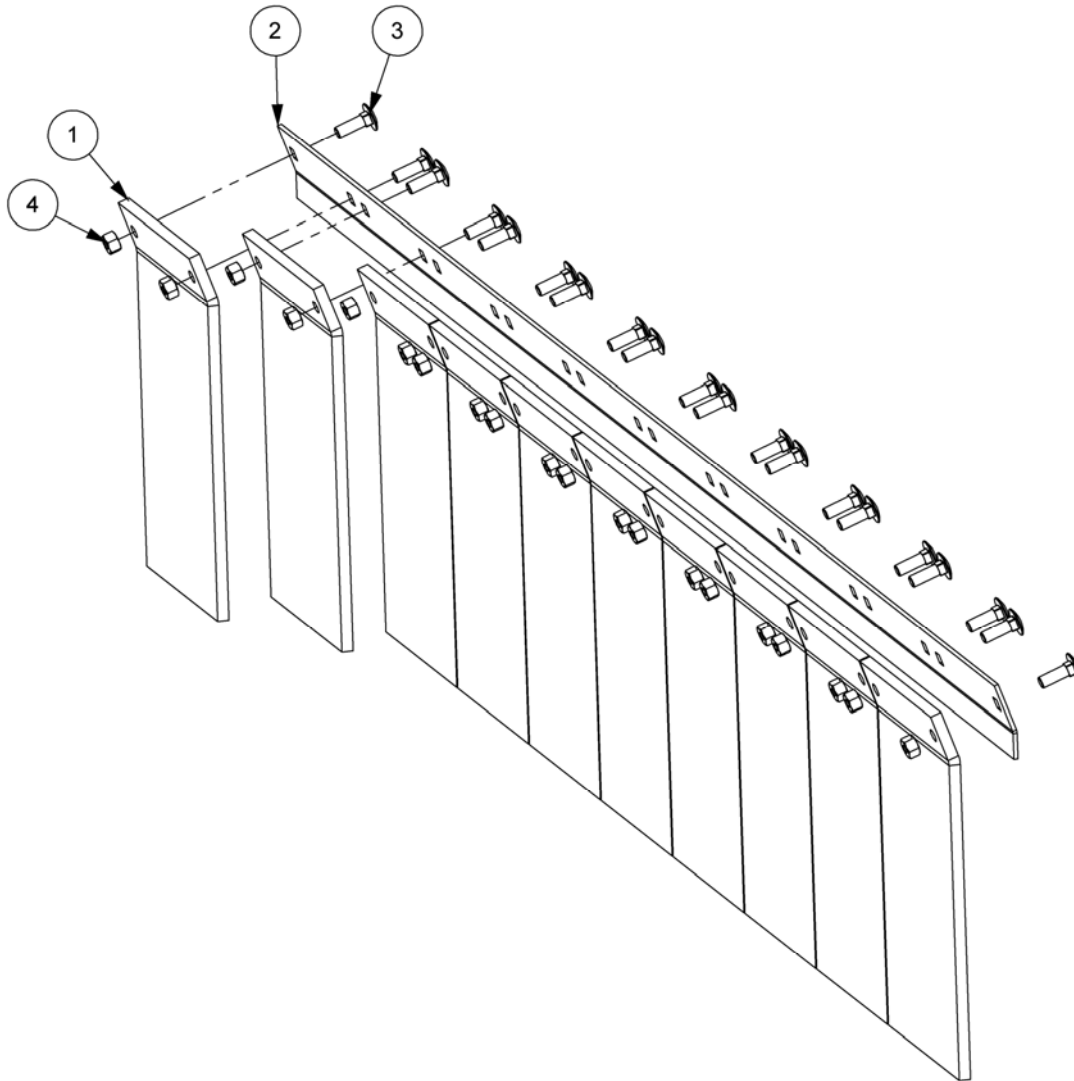

REF.	QTY.	PART No.	DESCRIPTION
		7198315	FRONT FLAP KIT
1	10	7190020	FRONT FLAP
2	1	7198065	FRONT CLAMP STRIP - 1.5m
3	20	9293054	CUP HEAD SQUARE SCREW
4	20	9143004	SELF-LOCKING NUT

SKID KIT

Module(s): 7290384

McCONNEL

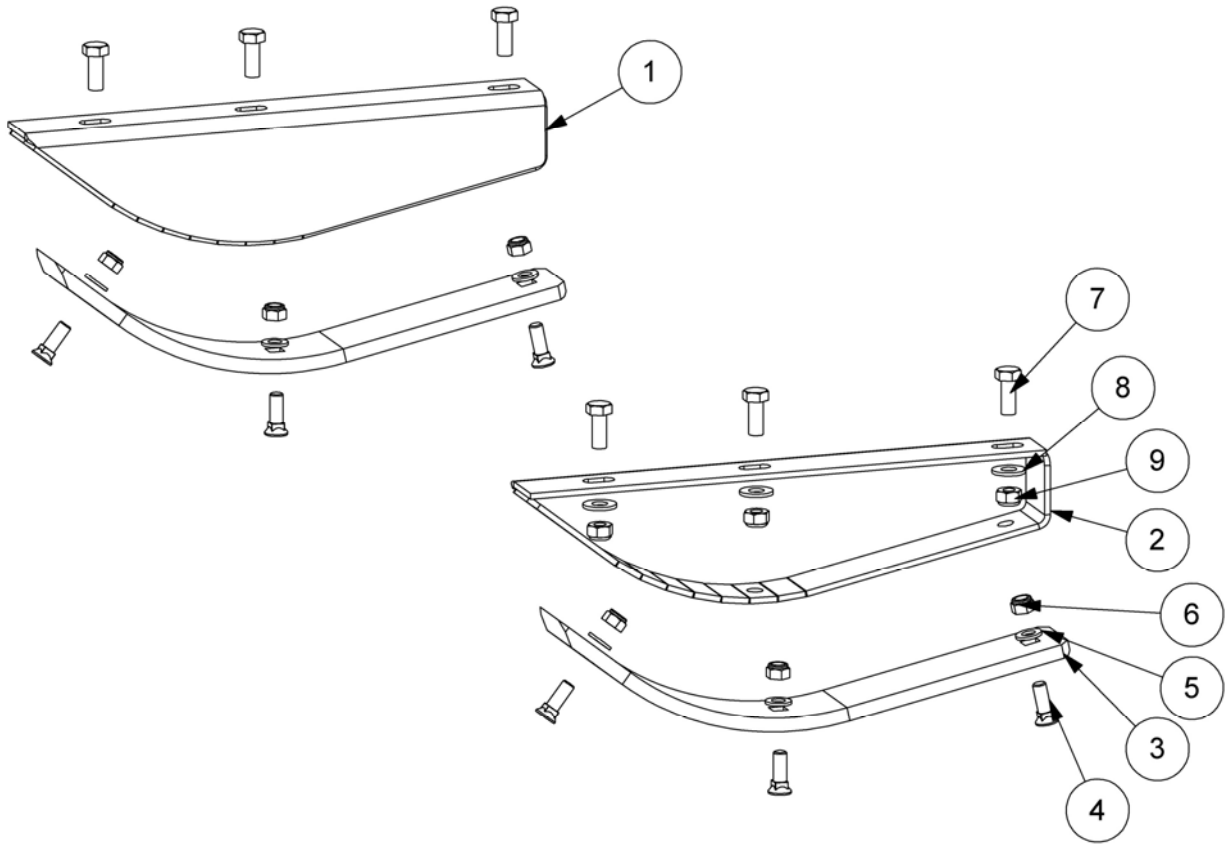

REF.	QTY.	PART No.	DESCRIPTION
		7290384	SKID KIT
1	1	7290389	SKID RH
2	1	7290390	SKID LH
3	2	7290391	REPLACEABLE SKID SHOE
4	6	6012034	PLOUGH BOLT c/w NUT
5	6	0100104	FLAT WASHER
6	6	0141004	UNF CLEVELOC NUT
7	6	9313066	SETSCREW
8	6	9100106	FLAT WASHER
9	6	9163006	NYLOC NUT



4

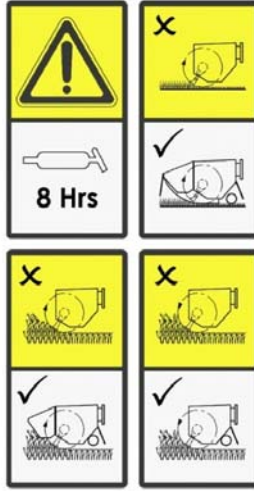

3

FLAIL PARTS INFORMATION

McConnel Flail Mowers use dynamically balanced and mated system components for Cutter Shafts (Rotors) Knives (Flails), Knife hangers (Shackles) bolts, bushes Rollers, Drivetrain Components, Bearing Belts and Belt Pulleys. McConnel parts are made and tested to meet close-tolerance specifications of balance, quality and consistency that assure long, trouble-free service. "Will-Fit" parts do not ordinarily meet McConnel Standards and could reduce Mower performance, void warranties and present an increase in the safety hazard potential.

DON'T GAMBLE!
USE GENUINE McCONNEL SERVICE PARTS
See your McConnel dealer

5

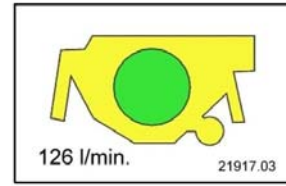

7

Item #7 located on motor

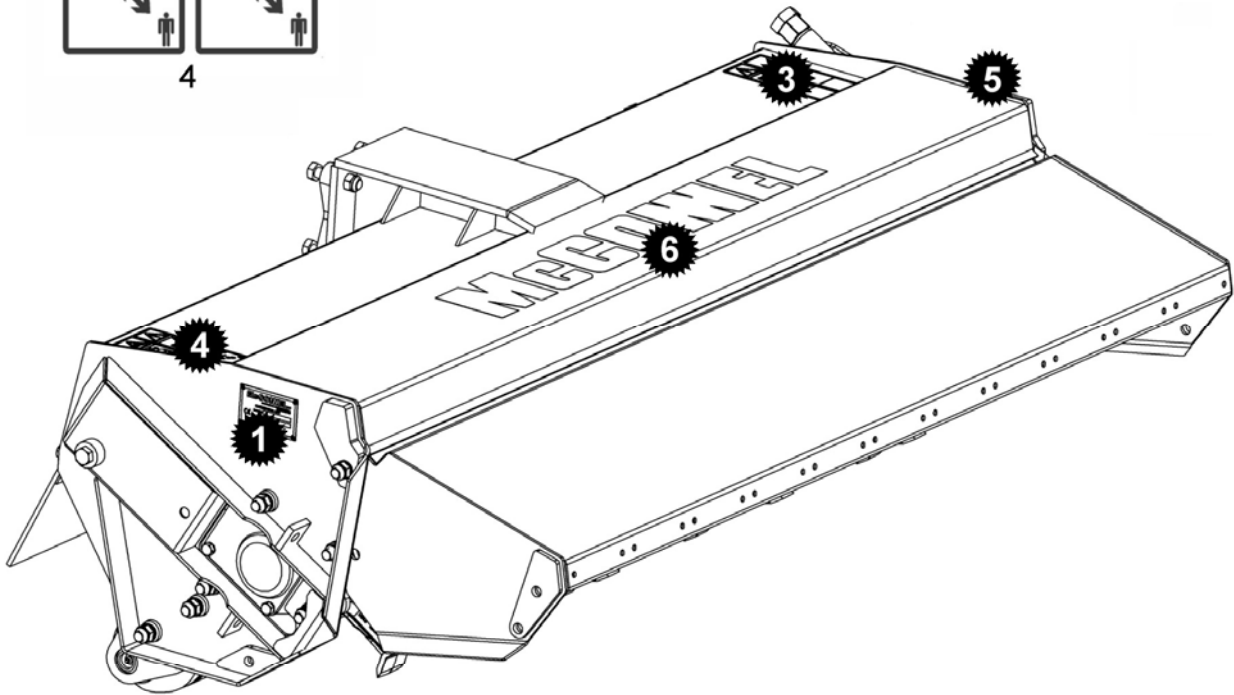

McCONEL LTD
LUDLOW, SYE S.A. PHONE: 01864 873731
FAX: 01864 874403
MADE IN ENGLAND

CE MACHINE _____
SERIAL No. _____
WEIGHT (KG) _____

1

McCONEL

6

Module(s): 7350707, 7350709

REF.	QTY.	PART No.	DESCRIPTION
		7350707	54HP FLAILHEAD DECAL KIT
1	1	1335246	SERIAL No. PLATE
2	4	7103230	POP RIVET
3	1	1290738	DECAL - FLAILHEAD
4	1	09.821.35	DECAL - COMBINED EURO
5	1	1290392	DECAL - PARTS
6	1	1290527	DECAL - McCONNEL
7	1	21917.02	DECAL - 102 l/min (ORANGE)

REF.	QTY.	PART No.	DESCRIPTION
		7350709	FLAILHEAD DECAL KIT
1	1	1335246	SERIAL No. PLATE
2	4	7103230	POP RIVET
3	1	1290738	DECAL - FLAILHEAD
4	1	09.821.35	DECAL - COMBINED EURO
5	1	1290392	DECAL - PARTS
6	1	1290527	DECAL - McCONNEL
7	1	21917.03	DECAL - 126 l/min (GREEN)



McConnel Limited, Temeside Works, Ludlow, Shropshire SY8 1JL. England.
Telephone: 01584 873131. Facsimile: 01584 876463. www.mcconnel.com